

Type: M3PRT/2 & M3PRT/2-4W

Phase Failure, Phase Sequence and Under Voltage plus Time Delay

- 35mm DIN rail housing
- Microprocessor controlled with internal monitoring (self-checking)
- Monitors own supply and detects an Under voltage condition on one or more phases
- M3PRT/2 measures phase to phase voltage and M3PRT/2-4W measures phase to neutral voltage
- Detects incorrect phase sequence, phase loss and neutral loss (4-wire only)
- Adjustment for under voltage trip level
- Adjustment for time delay (from an under voltage condition)
- 1 x DPDT relay output 8A
- Intelligent LED indication for supply and relay status



Dims:
to DIN 43880
W. 35mm

Terminal Protection to IP20

FUNCTION DIAGRAM

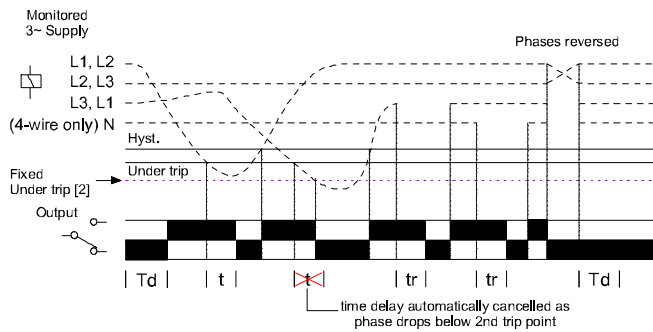

INSTALLATION AND SETTING



Installation work must be carried out by qualified personnel.

- BEFORE INSTALLATION, ISOLATE THE SUPPLY.
- Connect the unit as required. The diagram below shows a typical installation, whereby the supply to the load is being monitored by the relay. If a fault should occur, the contactor is de-energised removing the 3-phase supply to the load. The contactor only re-energises after the fault has cleared.

Applying power.

- Set the "trip level" and the "time delay" to minimum.
- Apply power and the green "supply on" and red "relay" LED's will illuminate, the relay will energise and contacts 15 and 18 / 25 and 28 will close. Refer to troubleshooting table if the unit fails to operate correctly.

Setting the unit.

- Accurate setting can be achieved by adjusting the "trip level" until the unit trips (relay de-energises) then by decreasing the "trip level" setting until the relay re-energises. By close setting of the "trip level", the unit will also detect a phase loss even with a large percentage of re-generative voltage.
- In order to set the unit as previously described but without causing disruption to the equipment being controlled/monitored, set the "time delay" to maximum. It will now be possible to establish the trip when the red "relay" LED starts to flash. Decrease the trip level setting to stop the LED flashing. (Note: If the time delay is allowed to expire, the output relay will de-energise).
- If large supply variations are anticipated, the "trip level" should be set further from the nominal voltage.
- Set the "time delay" as required. (Note that the delay is only effective should the supply drop below the set "trip level". However, if during an under voltage condition the supply drops below the 2nd under voltage trip level, any set time delay is automatically cancelled and the relay de-energises).

Troubleshooting. The table below shows the status of the unit during a fault condition.

Supply fault	Green LED	Red LED	Relay
Phase or Neutral (4-wire only) missing	Off	Off	De-energised
Phases reversed (no delay)	Flashing	Off	De-energised
Under Voltage condition (during timing)	On	Flashing	Energised for set delay (t)
Under Voltage condition (alter timing)	On	Off	De-energised
Phase below 70% of Un (fixed under trip level [2])	On	Off	De-energised
Phase below 50% of Un	Off	Off	De-energised

CONNECTION DIAGRAM

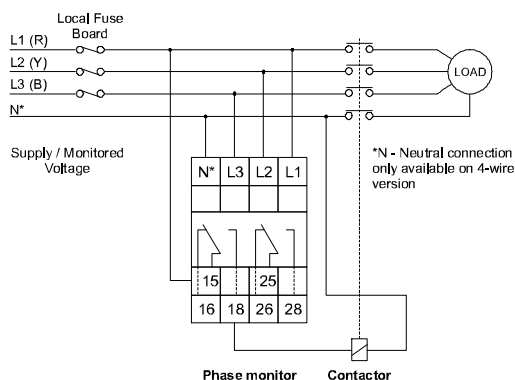

TECHNICAL SPECIFICATION

Supply / monitoring voltage U*:	M3PRT/2 (L1, L2, L3)	M3PRT/2-4W (L1, L2, L3, N)
	77 - 143V AC	44.5 - 82.5V AC
	161 - 300V AC	93 - 173V AC
	280 - 520V AC	161 - 300V AC
Frequency range:	48 - 63Hz	
Isolation:	Over voltage cat. III	
Rated impulse withstand voltage:	4kV (1.2 / 50µS) IEC 60664	
Power consumption: (max.)	L1: 20VA (3-wire), 13VA (4-wire) L2: 0.2VA (3-wire), 0.1VA (4-wire) L3: 20VA (3-wire), 0.1VA (4-wire)	

*Please state Supply / monitoring voltage when ordering

Trip levels:	Under [2] fixed ±2%:	Under (adjustable):
77 - 143V AC (3-wire)	77V	83 - 138V
161 - 300V AC (3-wire)	161V	173 - 288V
280 - 520V AC (3-wire)	280V	300 - 500V
44.5 - 82.5V AC (4-wire)	44.5V	48 - 79V
93 - 173V AC (4-wire)	93V	100 - 166V
161 - 300V AC (4-wire)	161V	173 - 288V
Repeat accuracy:	± 0.5% @ constant conditions	
Hysteresis:	≈ 2% of trip level (factory set)	
Response time:	≈ 50 ms	
Time delay (t):	0.2 - 10 sec (± 5%)	
	Note: actual delay (t) = adjustable delay + response time	

Delay from phase/neutral loss (tr):	≈ 100 ms (worst case = tr x 2)
Power on delay (Td):	≈ 1sec. (worst case = Td x 2)

Ambient temp:	-20 to + 60°C
Relative humidity:	+ 95%

Output:	DPDT relay (15, 16, 18 / 25, 26, 28)
Output rating:	AC1 250V 8A (2000VA) AC15 250V 3A DC1 25V 8A (200W)

Electrical life:	≥ 150,000 ops at rated load
Dielectric voltage:	2kV AC (rms) IEC 60947-1
Rated impulse withstand voltage:	4kV (1.2 / 50µS) IEC 60664

Housing:	Orange flame retardant UL94 VO
Weight:	≈ 100g
Mounting option:	On to 35mm symmetric DIN rail to BS5584:1978 (EN50 002, DIN 46277-3) Or direct surface mounting via 2 x M3.5 or 4BA screws using the black clips provided on the rear of the unit.

Terminal conductor size:	≤ 2 x 2.5mm ² solid or stranded
--------------------------	--

Approvals:	Conforms to IEC, CE and Compliant.
------------	------------------------------------

Options:	
----------	--

1. For other supply/monitoring voltages, please consult the sales office.
2. For alternative time delays or trip levels, please consult the sales office.

MOUNTING DETAILS

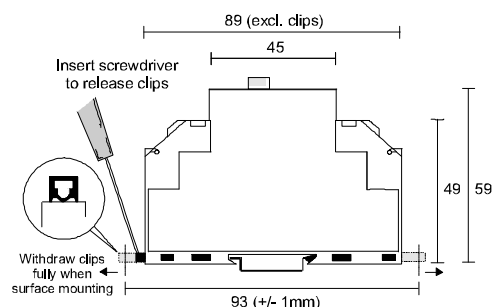

Broyce Control Ltd., Pool Street, Wolverhampton, West Midlands WV2 4HN. England

M3PRT2-2-A

Telephone: +44 (0) 1902 773746 Facsimile: +44 (0) 1902 420639 Email: sales@broycecontrol.com Web: <http://www.broycecontrol.com>
The information provided in this literature is believed to be accurate (subject to change without prior notice); however, use of such information shall be entirely at the user's own risk.