

LMH0002

SMPTE 292M / 259M Serial Digital Cable Driver

General Description

The LMH0002 SMPTE 292M / 259M serial digital cable driver is a monolithic, high-speed cable driver designed for use in SMPTE 292M / 259M serial digital video and ITU-T G.703 serial digital data transmission applications. The LMH0002 drives 75Ω transmission lines (Belden 8281, Belden 1694A or equivalent) at data rates up to 1.485 Gbps.

The LMH0002 provides two selectable slew rates for SMPTE 259M and SMPTE 292M compliance. The output voltage swing is adjustable via a single external resistor.

The LMH0002 is powered from a single 3.3V supply. Power consumption is typically 125 mW in SD mode and 149 mW in HD mode. The LMH0002 is available in an 8-pin SOIC or 16-pin LLP package.

Features

- SMPTE 292M, SMPTE 344M and SMPTE 259M compliant
- Supports DVB-ASI at 270 Mbps
- Data rates to 1.485 Gbps
- Differential input
- 75Ω differential output
- Selectable slew rate
- Adjustable output amplitude
- Single 3.3V supply operation
- Operating temperature range: Commercial 0°C to +70°C (LMH0002MA) or Industrial -40°C to +85°C (LMH0002TMA and LMH0002SQ)
- Typical power consumption: 125 mW in SD mode and 149 mW in HD mode
- 8-pin SOIC or 16-pin LLP package
- Replaces the GS1528, GS1528A, or GS1578A.

Applications

- SMPTE 292M, SMPTE 344M, and SMPTE 259M serial digital interfaces
- Sonet/SDH and ATM interfaces
- Digital routers and switches
- Distribution amplifiers
- Buffer applications
- Set top boxes
- Security cameras

Typical Application

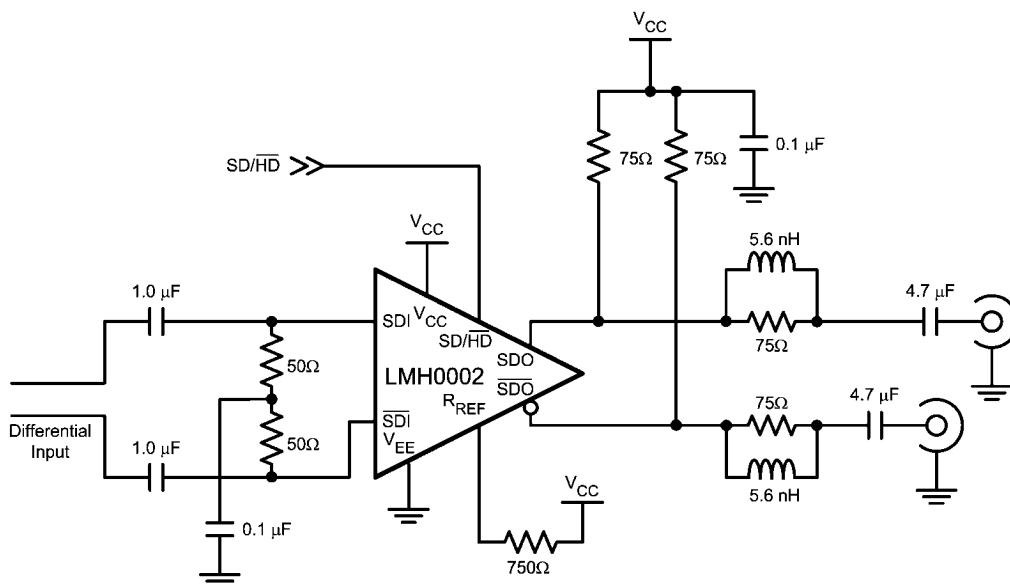

20176102

Absolute Maximum Ratings (Note 1)

Supply Voltage:	-0.5V to 3.6V
Input Voltage (all inputs)	-0.3V to $V_{CC}+0.3V$
Output Current	28 mA
Storage Temperature Range	-65°C to +150°C
Junction Temperature	+150°C
Lead Temperature (Soldering 4 Sec)	+260°C
Package Thermal Resistance	
θ_{JA} 8-pin SOIC	+160°C/W
θ_{JA} 16-pin LLP	+78.9°C/W
θ_{JC} 8-pin SOIC	+105°C/W
θ_{JC} 16-pin LLP	+42.7°C/W

ESD Rating (HBM)

5kV

ESD Rating (MM)

250V

Recommended Operating Conditions

Supply Voltage ($V_{CC} - V_{EE}$):	3.3V ±5%
Operating Free Air Temperature (T_A)	
LMH0002MA	0°C to +70°C
LMH0002TMA, LMH0002SQ	-40°C to +85°C

DC Electrical Characteristics

Over Supply Voltage and Operating Temperature ranges, unless otherwise specified (Notes 2, 3).

Symbol	Parameter	Conditions	Reference	Min	Typ	Max	Units
V_{CMIN}	Input Common Mode Voltage		SDI, \overline{SDI}	1.6 + $V_{SDI}/2$		$V_{CC} -$ $V_{SDI}/2$	V
V_{SDI}	Input Voltage Swing	Differential		100		2000	mV _{P-P}
V_{CMOUT}	Output Common Mode Voltage		SDO, \overline{SDO}		$V_{CC} -$ V_{SDO}		V
V_{SDO}	Output Voltage Swing	Single-ended, 75Ω load, $R_{REF} =$ 750Ω 1%		750	800	850	mV _{P-P}
		Single-ended, 75Ω load, $R_{REF} =$ 590Ω 1%		900	1000	1100	mV _{P-P}
	SD/ \overline{HD} Input Voltage	Min for SD	SD/ \overline{HD}	2.4			V
		Max for HD				0.8	V
	SD/ \overline{HD} Input Current				3.7		μA
I_{CC}	Supply Current	SD/ $\overline{HD} = 0$, (Note 5)			45	49	mA
		SD/ $\overline{HD} = 1$, (Note 5)			38	43	mA

AC Electrical Characteristics

Over Supply Voltage and Operating Temperature ranges, unless otherwise specified (Note 3).

Symbol	Parameter	Conditions	Reference	Min	Typ	Max	Units
DR_{SDI}	Input Data Rate	(Note 4)	SDI, \overline{SDI}			1485	Mbps
t_{jit}	Additive Jitter	1.485 Gbps	SDO, \overline{SDO}		26		ps _{P-P}
		270 Mbps			18		ps _{P-P}
t_r, t_f	Output Rise Time, Fall Time	SD/ $\overline{HD} = 0$, 20% – 80%, (Note 6)			120	220	ps
		SD/ $\overline{HD} = 1$, 20% – 80%		400	560	800	ps
	Mismatch in Rise/Fall Time	(Note 4)				30	ps
	Duty Cycle Distortion	SD/ $\overline{HD} = 0$, (Note 4)				30	ps
		SD/ $\overline{HD} = 1$, (Note 4)				100	ps
t_{OS}	Output Overshoot	(Note 4)				8	%
RL_{SDO}	Output Return Loss	(Note 7)		15	20		dB

Note 1: "Absolute Maximum Ratings" are those parameter values beyond which the life and operation of the device cannot be guaranteed. The stating herein of these maximums shall not be construed to imply that the device can or should be operated at or beyond these values. The table of "Electrical Characteristics" specifies acceptable device operating conditions.

Note 2: Current flow into device pins is defined as positive. Current flow out of device pins is defined as negative. All voltages are stated referenced to $V_{EE} = 0$ Volts.

Note 3: Typical values are stated for $V_{CC} = +3.3V$ and $T_A = +25^\circ C$.

Note 4: Specification is guaranteed by characterization.

Note 5: Maximum I_{CC} is measured at $V_{CC} = +3.465V$ and $T_A = +70^{\circ}C$.

Note 6: Specification is guaranteed by characterization and verified by test.

Note 7: Output return loss is dependent on board design. The LMH0002 meets this specification on the SD002 evaluation board from 5MHz to 1.5GHz.

Connection Diagrams

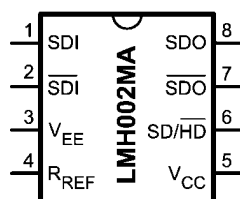

20176101

8-Pin SOIC

Order Number LMH0002MA or LMH0002TMA
See NS Package Number M08A

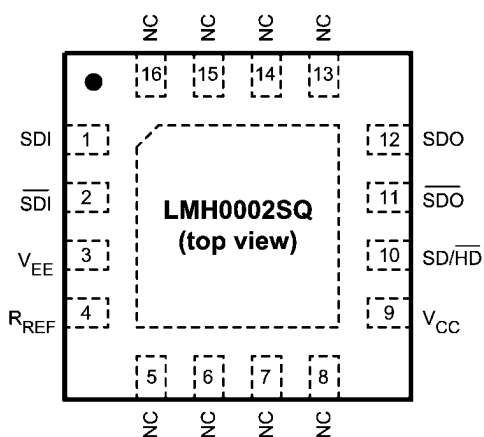

20176105

16-Pin LLP

Order Number LMH0002SQ
See NS Package Number SQB16A

Pin Descriptions

SOIC Pin #	LLP Pin #	Name	Description
1	1	SDI	Serial data true input.
2	2	$\overline{\text{SDI}}$	Serial data complement input.
3	3	V_{EE}	Negative power supply (ground).
4	4	R_{REF}	Output driver level control. Connect a resistor to V_{CC} to set output voltage swing.
5	9	V_{CC}	Positive power supply (+3.3V).
6	10	$\overline{\text{SD/HD}}$	Output slew rate control. Output rise/fall time complies with SMPTE 292M when low and SMPTE 259M when high.
7	11	$\overline{\text{SDO}}$	Serial data complement output.
8	12	SDO	Serial data true output.
—	5, 6, 7, 8, 13, 14, 15, 16	NC	No connect.
—	DAP	V_{EE}	Connect exposed DAP to negative power supply (ground).

Device Operation

INPUT INTERFACING

The LMH0002 accepts either differential or single-ended input. The inputs are self-biased, allowing for simple AC or DC coupling. DC-coupled inputs must be kept within the specified common-mode range. SDI and $\overline{\text{SDI}}$ are self-biased at approximately 2.1V with $V_{CC} = 3.3\text{V}$. Figure 1 shows the differential input stage for SDI and $\overline{\text{SDI}}$.

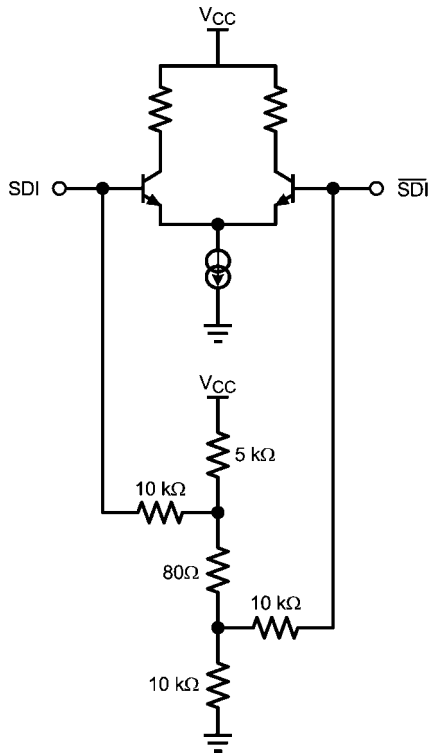

20176104

FIGURE 1. Differential Input Stage for SDI and $\overline{\text{SDI}}$.

OUTPUT INTERFACING

The LMH0002 uses current mode outputs. Single-ended output levels are 800 mV_{P-P} into 75Ω AC-coupled coaxial cable (with $R_{REF} = 750\Omega$). Output level is controlled by the value of the R_{REF} resistor connected between the R_{REF} pin and V_{CC} .

The R_{REF} resistor should be placed as close as possible to the R_{REF} pin. In addition, the copper in the plane layers below the R_{REF} network should be removed to minimize parasitic capacitance.

OUTPUT SLEW RATE CONTROL

The LMH0002 output rise and fall times are selectable for either SMPTE 259M or SMPTE 292M compliance via the SD/ $\overline{\text{HD}}$ pin. For slower rise and fall times, or SMPTE 259M compliance, SD/ $\overline{\text{HD}}$ is set high. For faster rise and fall times, or SMPTE 292M compliance, SD/ $\overline{\text{HD}}$ is set low.

REPLACING THE GENNUM GS1528, GS1528A, and GS1578A

The LMH0002MA is form-fit-function compatible with the Gennum GS1528 and GS1528A. The LMH0002SQ is form-fit-function compatible with the Gennum GS1578A.

Physical Dimensions inches (millimeters) unless otherwise noted

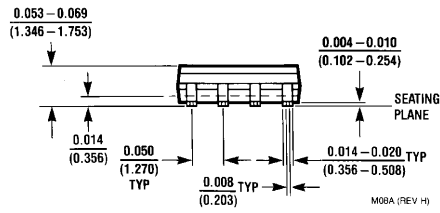
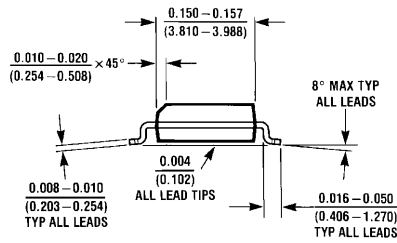
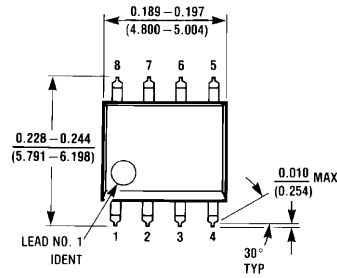

8-Pin SOIC
Order Number LMH0002MA or LMH0002TMA
NS Package Number M08A

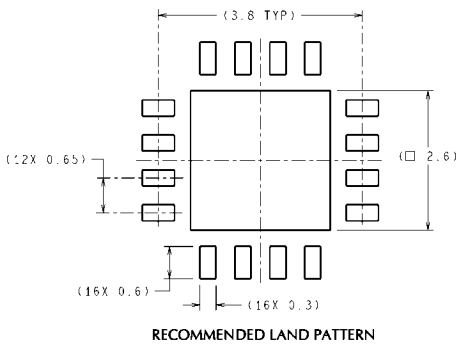

DIMENSIONS ARE IN MILLIMETERS
 DIMENSIONS IN () FOR REFERENCE ONLY

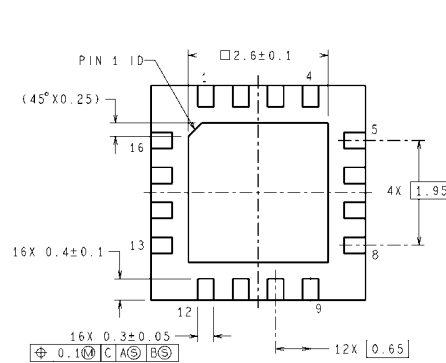
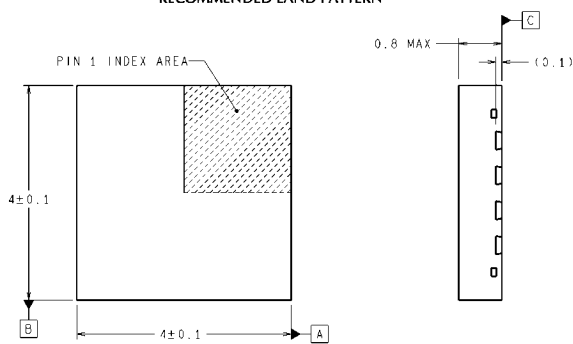

16-Pin LLP
Order Number LMH0002SQ
NS Package Number SQB16A

SQB16A (Rev A)

Notes

For more National Semiconductor product information and proven design tools, visit the following Web sites at:

Products		Design Support	
Amplifiers	www.national.com/amplifiers	WEBENCH	www.national.com/webench
Audio	www.national.com/audio	Analog University	www.national.com/AU
Clock Conditioners	www.national.com/timing	App Notes	www.national.com/appnotes
Data Converters	www.national.com/adc	Distributors	www.national.com/contacts
Displays	www.national.com/displays	Green Compliance	www.national.com/quality/green
Ethernet	www.national.com/ethernet	Packaging	www.national.com/packaging
Interface	www.national.com/interface	Quality and Reliability	www.national.com/quality
LVDS	www.national.com/lvds	Reference Designs	www.national.com/refdesigns
Power Management	www.national.com/power	Feedback	www.national.com/feedback
Switching Regulators	www.national.com/switchers		
LDOs	www.national.com/lido		
LED Lighting	www.national.com/led		
PowerWise	www.national.com/powerwise		
Serial Digital Interface (SDI)	www.national.com/sdi		
Temperature Sensors	www.national.com/tempsensors		
Wireless (PLL/VCO)	www.national.com/wireless		

THE CONTENTS OF THIS DOCUMENT ARE PROVIDED IN CONNECTION WITH NATIONAL SEMICONDUCTOR CORPORATION ("NATIONAL") PRODUCTS. NATIONAL MAKES NO REPRESENTATIONS OR WARRANTIES WITH RESPECT TO THE ACCURACY OR COMPLETENESS OF THE CONTENTS OF THIS PUBLICATION AND RESERVES THE RIGHT TO MAKE CHANGES TO SPECIFICATIONS AND PRODUCT DESCRIPTIONS AT ANY TIME WITHOUT NOTICE. NO LICENSE, WHETHER EXPRESS, IMPLIED, ARISING BY ESTOPPEL OR OTHERWISE, TO ANY INTELLECTUAL PROPERTY RIGHTS IS GRANTED BY THIS DOCUMENT.

TESTING AND OTHER QUALITY CONTROLS ARE USED TO THE EXTENT NATIONAL DEEMS NECESSARY TO SUPPORT NATIONAL'S PRODUCT WARRANTY. EXCEPT WHERE MANDATED BY GOVERNMENT REQUIREMENTS, TESTING OF ALL PARAMETERS OF EACH PRODUCT IS NOT NECESSARILY PERFORMED. NATIONAL ASSUMES NO LIABILITY FOR APPLICATIONS ASSISTANCE OR BUYER PRODUCT DESIGN. BUYERS ARE RESPONSIBLE FOR THEIR PRODUCTS AND APPLICATIONS USING NATIONAL COMPONENTS. PRIOR TO USING OR DISTRIBUTING ANY PRODUCTS THAT INCLUDE NATIONAL COMPONENTS, BUYERS SHOULD PROVIDE ADEQUATE DESIGN, TESTING AND OPERATING SAFEGUARDS.

EXCEPT AS PROVIDED IN NATIONAL'S TERMS AND CONDITIONS OF SALE FOR SUCH PRODUCTS, NATIONAL ASSUMES NO LIABILITY WHATSOEVER, AND NATIONAL DISCLAIMS ANY EXPRESS OR IMPLIED WARRANTY RELATING TO THE SALE AND/OR USE OF NATIONAL PRODUCTS INCLUDING LIABILITY OR WARRANTIES RELATING TO FITNESS FOR A PARTICULAR PURPOSE, MERCHANTABILITY, OR INFRINGEMENT OF ANY PATENT, COPYRIGHT OR OTHER INTELLECTUAL PROPERTY RIGHT.

LIFE SUPPORT POLICY

NATIONAL'S PRODUCTS ARE NOT AUTHORIZED FOR USE AS CRITICAL COMPONENTS IN LIFE SUPPORT DEVICES OR SYSTEMS WITHOUT THE EXPRESS PRIOR WRITTEN APPROVAL OF THE CHIEF EXECUTIVE OFFICER AND GENERAL COUNSEL OF NATIONAL SEMICONDUCTOR CORPORATION. As used herein:

Life support devices or systems are devices which (a) are intended for surgical implant into the body, or (b) support or sustain life and whose failure to perform when properly used in accordance with instructions for use provided in the labeling can be reasonably expected to result in a significant injury to the user. A critical component is any component in a life support device or system whose failure to perform can be reasonably expected to cause the failure of the life support device or system or to affect its safety or effectiveness.

National Semiconductor and the National Semiconductor logo are registered trademarks of National Semiconductor Corporation. All other brand or product names may be trademarks or registered trademarks of their respective holders.

Copyright© 2008 National Semiconductor Corporation

For the most current product information visit us at www.national.com



National Semiconductor Americas Technical Support Center
 Email: support@nsc.com
 Tel: 1-800-272-9959

National Semiconductor Europe Technical Support Center
 Email: europe.support@nsc.com
 German Tel: +49 (0) 180 5010 771
 English Tel: +44 (0) 870 850 4288

National Semiconductor Asia Pacific Technical Support Center
 Email: ap.support@nsc.com

National Semiconductor Japan Technical Support Center
 Email: jpn.feedback@nsc.com