

Spur Gearhead GS 24 Ø24 mm, 0.1 Nm

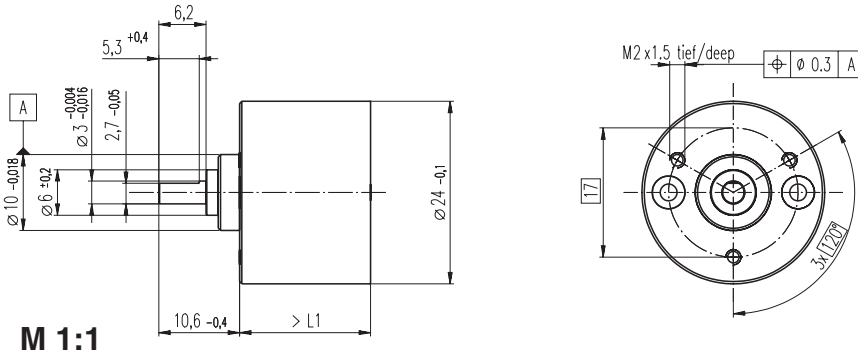

Technical Data

Spur Gearhead	straight teeth
Housing	plastic
Output shaft	stainless steel, hardened
Bearing at output	sleeve bearings
Radial play, 8 mm from flange	max. 0.038 mm
Axial play	0.03 - 0.30 mm
Max. perm. radial load, 8 mm from flange	5 N
Max. permissible axial load	8 N
Max. permissible force for press fits	500 N
Average backlash no load	< 2.5°
Recommended input speed	< 4000 rpm
Recommended temperature range	-20 ... +65°C

- Stock program
- Standard program
- Special program (on request!)

Order Number

	110480	110481	110482	110483	110484	110485	110486
1 Reduction	7.2 : 1	20 : 1	32 : 1	64 : 1	131 : 1	199 : 1	325 : 1
2 Reduction absolute	93/13	121915/6153	151813/4695	837/13	212629/1625	778642/3909	1093365/3362
3 Number of stages	2	4	4	4	4	6	6
4 Max. continuous torque at gear output Nm	0.1	0.1	0.1	0.1	0.1	0.1	0.1
5 Intermittently permissible torque at gear output Nm	0.15	0.15	0.15	0.15	0.15	0.15	0.15
6 Sense of rotation, drive to output	=	=	=	=	=	=	=
7 Max. efficiency %	81	66	66	66	66	53	53
8 Weight g	25	28	28	28	28	30	30
9 Gearhead length L1* mm	13.7	17.4	17.4	17.4	17.4	21.2	21.2

* for A-max 19 is L1 + 2.8 mm

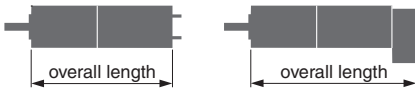

Combination:

+ Motor	Page	+ Tacho / Encoder / Brake	Page	Overall length [mm] = Motor length + gearhead length + (tacho / encoder / brakes) + assembly parts						
A-max 19	105/106			45.5	49.2	49.2	49.2	49.2	53.0	53.0
A-max 19	105	Digital Magnetic Encoder 13	223	53.0	56.7	56.7	56.7	56.7	60.5	60.5
A-max 19	106	MR Encoder	210/211	50.6	54.3	54.3	54.3	54.3	58.1	58.1
A-max 19	106	Digital Encoder 22	215	59.9	63.6	63.6	63.6	63.6	67.4	67.4
A-max 19	107/108			48.1	51.8	51.8	51.8	51.8	55.6	55.6
A-max 19	107	Digital Magnetic Encoder 13	223	54.8	58.5	58.5	58.5	58.5	62.3	62.3
A-max 19	108	MR Encoder	210/211	52.4	56.1	56.1	56.1	56.1	59.9	59.9
A-max 19	108	Digital Encoder 22	215	62.5	66.2	66.2	66.2	66.2	70.0	70.0
A-max 22	109-112			45.7	49.4	49.4	49.4	49.4	53.2	53.2
A-max 22	109/111	Digital Magnetic Encoder 13	223	52.8	56.5	56.5	56.5	56.5	60.3	60.3
A-max 22	110/112	MR Encoder	210/211	50.7	54.4	54.4	54.4	54.4	58.2	58.2
A-max 22	110/112	Digital Encoder 22	215	60.1	63.8	63.8	63.8	63.8	67.6	67.6