

NAIS

16A Power Relay For Home appliances

LE-RELAYS

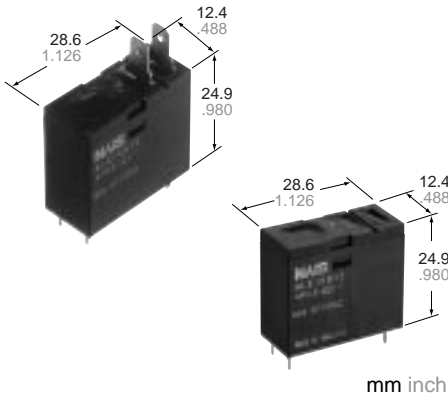

FEATURES

- 1. Ideal for magnetron and heater loads**
- 2. Excellent heat resistance**
 - This satisfies UL coil insulation class B
- 3. High insulation resistance**
 - Creepage distance and clearances between contact and coil: Min. 8 mm .315 inch
 - Surge withstand voltage: Min. 10,000V
- 4. Low operating power**
 - Nominal operating power: 400mW

5. A wide variety of types

- Product line consists of 4 types with different shapes and pins

6. Conforms to the various safety standards:

- UL/CSA, TÜV, approved and VDE, SEMKO pending

(UL File No. : E43028)
 (CSA File No. : LR26550)

SPECIFICATIONS

Contact

Arrangement	1 Form A	
Initial contact resistance, max. (By voltage drop 6 V DC 1 A)	100 mΩ	
Contact material	Silver alloy	
Rating (resistive load)	Nominal switching capacity	16 A 277 V AC
	Max. switching power	4,432 V A
	Max. switching voltage	277 V AC
	Max. switching current	16 A
Expected life (min. operations)	Mechanical (at 180 cpm)	2 × 10 ⁶
	Electrical (at 20 cpm) (Resistive load)	10 ⁵

Coil

Nominal operating power	400 mW
-------------------------	--------

Remarks

- * Specifications will vary with foreign standards certification ratings.
- *1 Measurement at same location as "Initial breakdown voltage" section.
- *2 Detection current: 10mA
- *3 Wave is standard shock voltage of ±1.2 × 50μs according to JEC-212-1981
- *4 Excluding contact bounce time.
- *5 Half-wave pulse of sine wave: 11 ms; detection time: 10 μs
- *6 Half-wave pulse of sine wave: 6 ms
- *7 Detection time: 10 μs
- *8 Refer to 6. Usage, transport and storage conditions mentioned in NOTES

Characteristics

Max. operating speed (at rated load)	20 cpm	
Initial insulation resistance*1	Min. 1,000 MΩ (at 500 V DC)	
Initial breakdown voltage*2	Between open contacts	1,000 Vrms for 1 min.
	Between contacts and coil	4,000 Vrms for 1 min.
Surge voltage between contact and coil*3	Min. 10,000 V	
Operate time*4 (at nominal voltage)	Approx. 20ms	
Release time (without diode)*4 (at nominal voltage)	Approx. 20ms	
Temperature rise (at nominal voltage)	Max. 55°C (resistance method, contact current 16 A, rated coil voltage, 20°C 68°F)	
Shock resistance	Functional*5	Min. 200 m/s ² {20 G}
	Destructive*6	Min. 1,000 m/s ² {100 G}
Vibration resistance	Functional*7	10 to 55Hz at double amplitude of 1.5mm
	Destructive	10 to 55Hz at double amplitude of 1.5mm
Conditions for operation, transport and storage*8 (Not freezing and condensing at low temperature)	Ambient temp.	-40°C to +85°C -40°F to +185°F
	Humidity	5 to 85% R.H.
Unit weight	Approx. 17 g .60 oz	

TYPICAL APPLICATIONS

- Microwave ovens
- Refrigerators
- OA equipment

ORDERING INFORMATION

Ex. A LE 1 2 B 12

Product name	Contact arrangement	Terminal shape	Coil insulation class	Coil voltage, V DC
LE	1: 1 Form A	2: TMP type/PCB side three terminals (includes one dummy terminal) 3: TMP type/PCB side three terminals 4: TMP type/PCB side four terminals 5: PCB type (No tab terminals)	B: Class B insulation	05: 5 18: 18 06: 6 24: 24 09: 9 48: 48 12: 12

Note: Standard packing; Carton: 100 pcs. Case 500 pcs.

TYPES

Contact arrangement	Coil voltage, V DC	TMP type/PCB side three terminals (includes one dummy terminal)	TMP type/PCB side three terminals	TMP type/PCB side four terminals	PCB type (No tab terminals)
		Part No.	Part No.	Part No.	Part No.
1 Form A	5	ALE12B05	ALE13B05	ALE14B05	ALE15B05
	6	ALE12B06	ALE13B06	ALE14B06	ALE15B06
	9	ALE12B09	ALE13B09	ALE14B09	ALE15B09
	12	ALE12B12	ALE13B12	ALE14B12	ALE15B12
	18	ALE12B18	ALE13B18	ALE14B18	ALE15B18
	24	ALE12B24	ALE13B24	ALE14B24	ALE15B24
	48	ALE12B48	ALE13B48	ALE14B48	ALE15B48

COIL DATA

Nominal voltage, V DC	Pick-up voltage, V DC (max.)	Drop-out voltage, V DC (min.)	Coil resistance, $\Omega(\pm 10\%)$	Nominal operating current, mA ($\pm 10\%$)	Nominal operating power, W	Maximum allowable voltage, V DC
5	3.8	0.3	63	80	0.4	7.2
6	4.5	0.3	90	66.7		8.7
9	6.8	0.5	203	44.4		13.0
12	9	0.6	360	33.3		17.4
18	13.5	0.9	810	22.2		26.1
24	18	1.2	1,440	16.7		34.8
48	36	2.4	5,760	8.3		69.6

DIMENSIONS

1. TMP type
PCB side three terminals
(includes one dummy terminal)

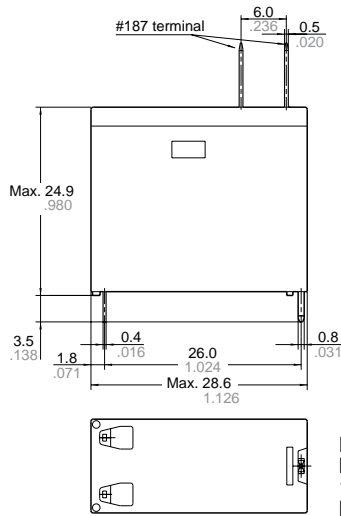

Dimension
Max. 1mm .039 inch:
1 to 3mm .039 to .118 inch:
Min. 3mm .118 inch:

Tolerance
 $\pm 0.1 \pm .004$
 $\pm 0.2 \pm .008$
 $\pm 0.3 \pm .012$

mm inch

PC board pattern (Bottom view)

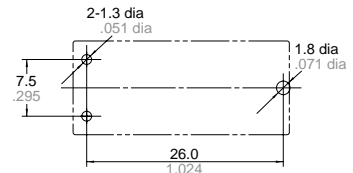

Tolerance : $\pm 0.1 \pm .004$

Schematic (Bottom view)

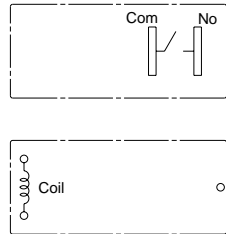

PCB side three terminals

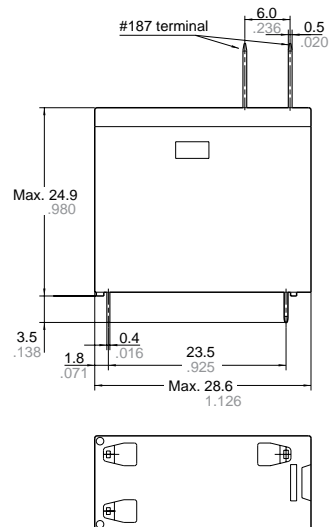

Dimension
Max. 1mm .039 inch:
1 to 3mm .039 to .118 inch:
Min. 3mm .118 inch:

Tolerance
 $\pm 0.1 \pm .004$
 $\pm 0.2 \pm .008$
 $\pm 0.3 \pm .012$

mm inch

PC board pattern (Bottom view)

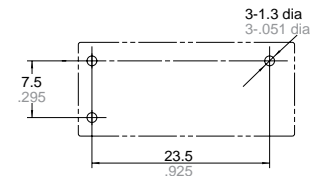

Tolerance : $\pm 0.1 \pm .004$

Schematic (Bottom view)

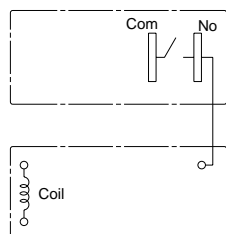

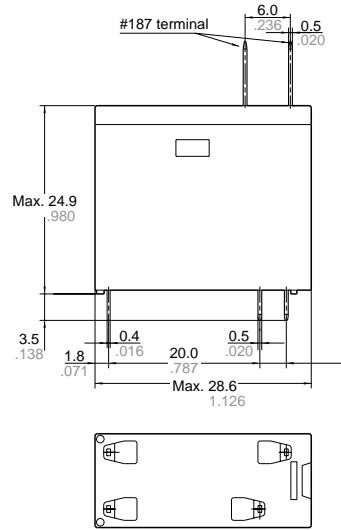

Dimension
 Max. 1mm .039 inch:
 1 to 3mm .039 to .118 inch:
 Min. 3mm .118 inch:

Tolerance
 $\pm 0.1 \pm .004$
 $\pm 0.2 \pm .008$
 $\pm 0.3 \pm .012$

PC board pattern (Bottom view)

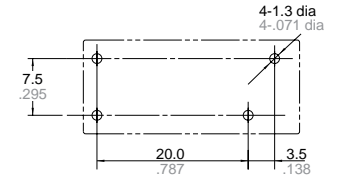

Tolerance : $\pm 0.1 \pm .004$

Schematic (Bottom view)

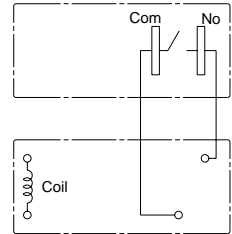

2. PCB type
 PCB side four terminals
 (No tab terminals)

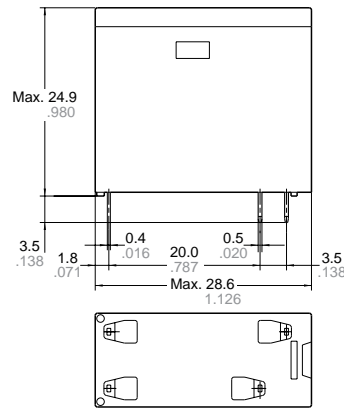

Dimension
 Max. 1mm .039 inch:
 1 to 3mm .039 to .118 inch:
 Min. 3mm .118 inch:

Tolerance
 $\pm 0.1 \pm .004$
 $\pm 0.2 \pm .008$
 $\pm 0.3 \pm .012$

PC board pattern (Bottom view)

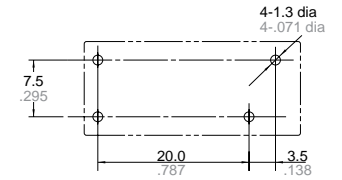

Tolerance : $\pm 0.1 \pm .004$

Schematic (Bottom view)



REFERENCE DATA

1. Coil temperature rise

Sample: ALE15B12, 6 pcs.
 Point measured: coil inside
 Ambient temperature: 25°C 77°F, 85°C 185°F

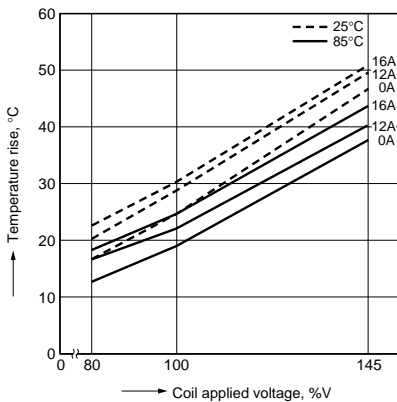

2. Electrical life test (16 A 277 V AC, resistive load)

Sample: ALE15B12, 6 pcs.
 Operation frequency: 20 times/min.
 (ON/OFF = 1.5s: 1.5s)
 Ambient temperature: Room temperature
 Circuit:

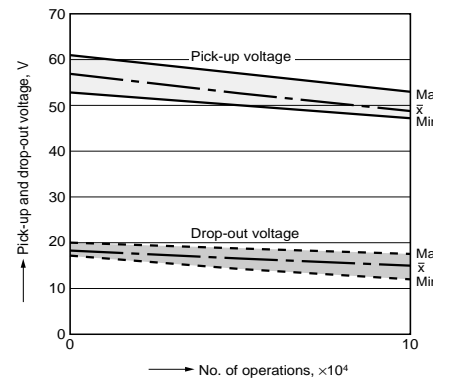
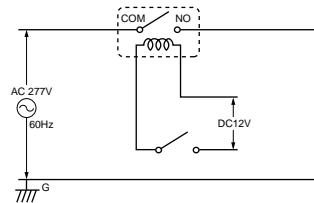

NOTES

1. Coil operating power

Pure DC current should be applied to the coil. The wave form should be rectangular. If it includes ripple, the ripple factor should be less than 5%. However, check it with the actual circuit since the characteristics may be slightly different.

2. Voltage applied to coil

To ensure reliable operation, please apply nominal voltage to the coil. Beware of the fact that pick-up voltage and dropout voltage vary depending on the ambient temperature and conditions.

3. Cleaning

This relay is not the sealed type, so it cannot be immersion cleaned. Be careful that flux does not overflow onto the PC board or penetrate inside the relay.

4. Operating life

Operating life varies depending on the type and load of the coil drive circuit, as well as factors like the operating frequency, operating phase and ambient atmosphere, so please check with actual equipment.

5. Soldering

We recommend the following soldering conditions.

1) Automatic soldering

* Preheating: 100°C 212°F, within 2 mins (PC board solder surface)

* Soldering: 260°C 500°F, within 5 s

2) Hand soldering

* Iron tip temperature: 280 to 300°C 536 to 572°F

* Soldering iron: 30 to 60W

* Soldering time: Within 5 s

6. Usage, transport and storage conditions

1) Ambient temperature, humidity, and atmospheric pressure during usage, transport, and storage of the relay:

(1) Temperature:

-40 to +85°F -40 to +185°F

(2) Humidity: 5 to 85% RH

(Avoid freezing and condensation.)

The humidity range varies with the temperature. Use within the range indicated in the graph below.

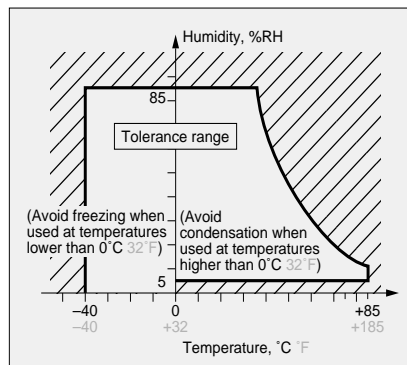

(3) Atmospheric pressure: 86 to 106 kPa

2) Condensation

Condensation forms when there is a sudden change in temperature under high temperature and high humidity conditions. Condensation will cause deterioration of the relay insulation.

3) Freezing

Condensation or other moisture may freeze on the relay when the temperature is lower than 0°C 32°F. This causes problems such as sticking of movable parts or operational time lags.

4) Low temperature, low humidity environments

The plastic becomes brittle if the relay is exposed to a low temperature, low humidity environment for long periods of time.

7. Others

1) If in error the relay has been dropped, the appearance and characteristics should be checked before use without fail.

2) Please do not use the coating material of organic system which contains solvents such as xylene and toluene for this product.

These materials are printed on 100% recycled paper.
These materials are printed with earth-friendly vegetable-based (soybean oil) ink.



Please contact

Matsushita Electric Works, Ltd.

Automation Controls Company

K Head Office: 1048, Kadoma, Kadoma-shi, Osaka 571-8686, Japan

K Telephone: Japan (81) Osaka (06) 6908-1050

K Facsimile: Japan (81) Osaka (06) 6908-5781

<http://www.mew.co.jp/e-acg/>

COPYRIGHT © 1999 All Rights Reserved