

THIS DRAWING IS UNPUBLISHED. RELEASED FOR PUBLICATION
 © COPYRIGHT BY TYCO ELECTRONICS CORPORATION. ALL RIGHTS RESERVED.

LOC	DIST	REVISIONS					
		P	LTR	DESCRIPTION	DATE	DWN	APVD
AD	39	N1		ECO--06-9241	27APR06	MB	DR

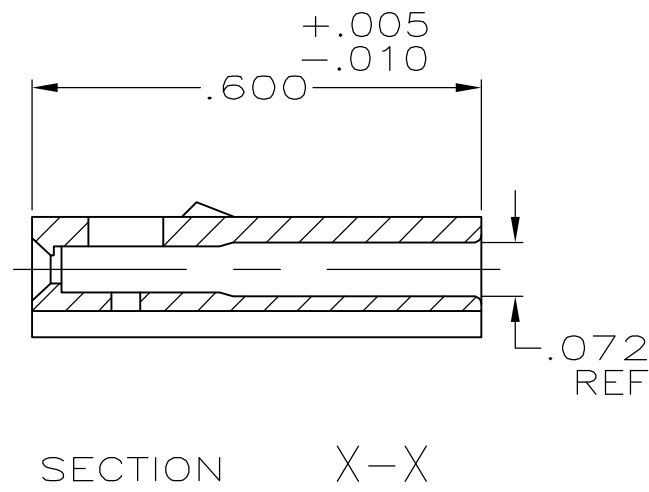
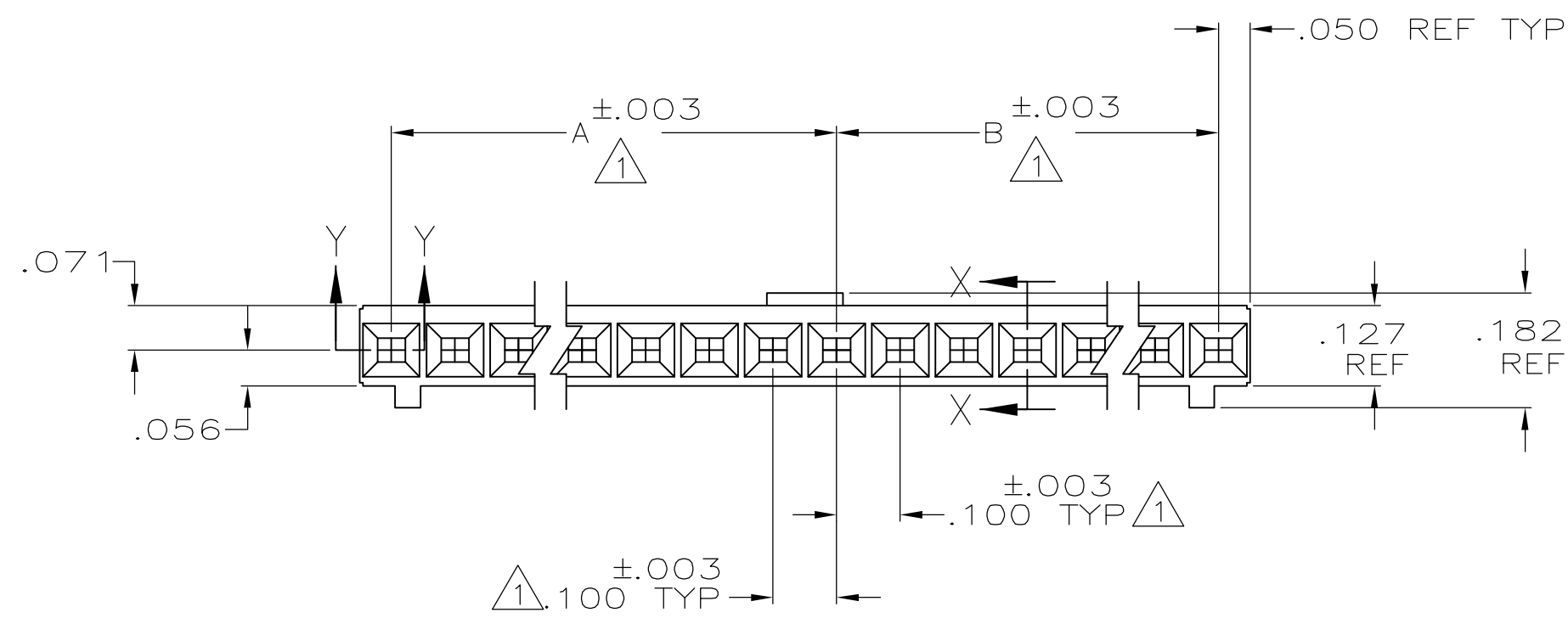
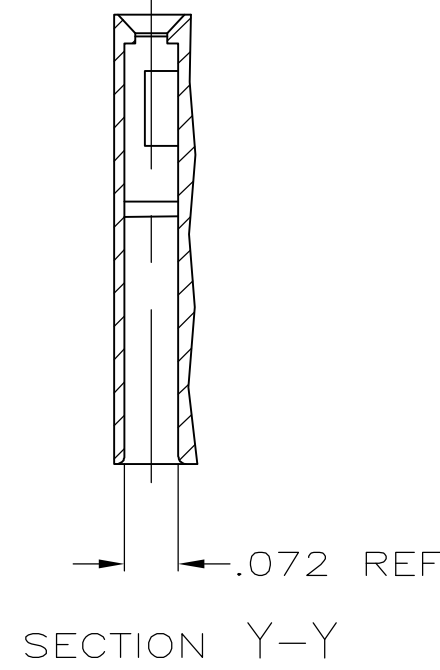
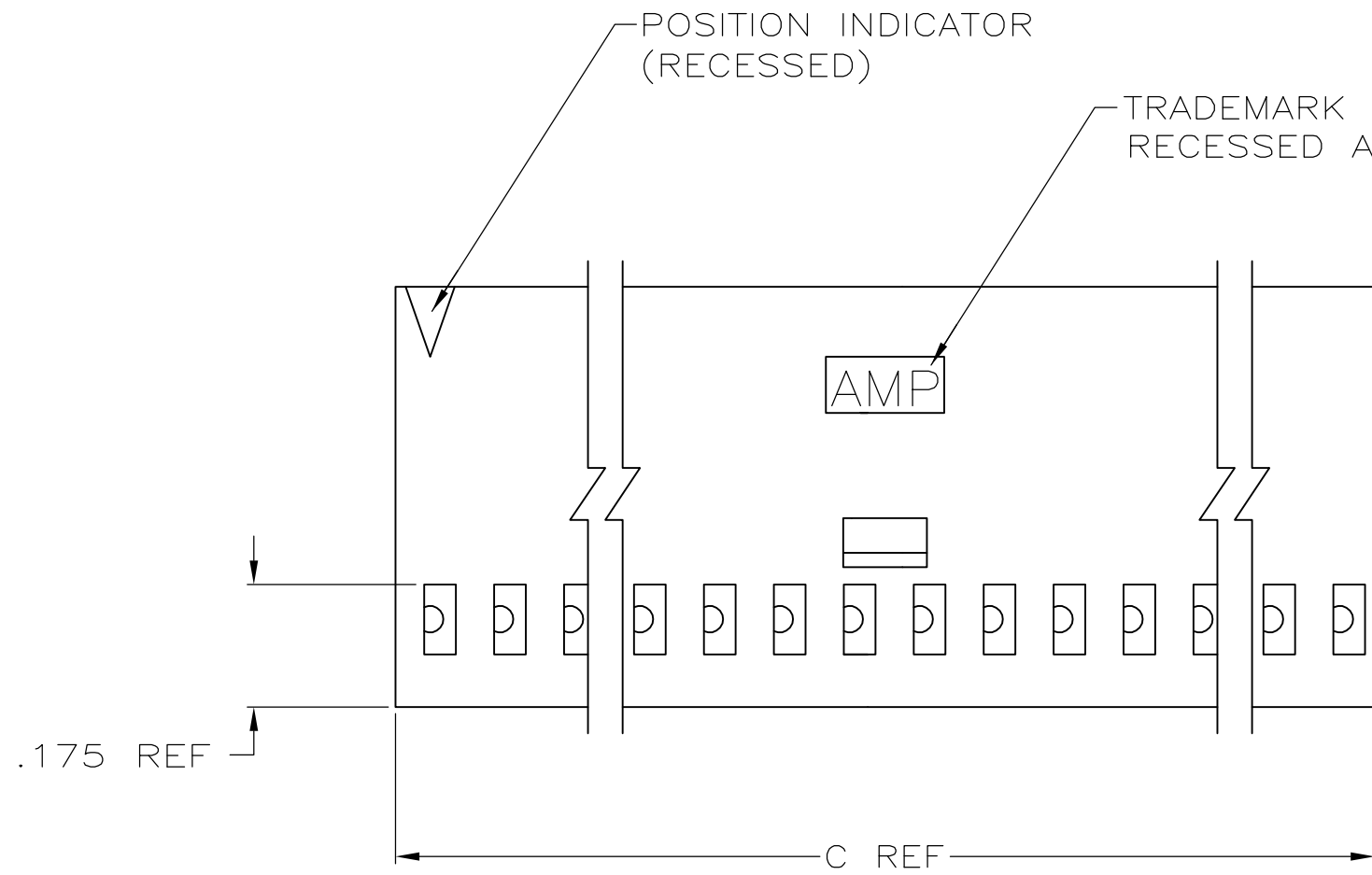

C	B	A	NO OF POS	PART NUMBER
3.600	1.700	1.800	36	3-102241-4
3.500	1.700	1.700	35	3-102241-3
3.400	1.600	1.700	34	3-102241-2
3.300	1.600	1.600	33	3-102241-1
3.200	1.500	1.600	32	3-102241-0
3.100	1.500	1.500	31	2-102241-9
3.000	1.400	1.500	30	2-102241-8
2.900	1.400	1.400	29	2-102241-7
2.800	1.300	1.400	28	2-102241-6
2.700	1.300	1.300	27	2-102241-5
2.600	1.200	1.300	26	2-102241-4
2.500	1.200	1.200	25	2-102241-3
2.400	1.100	1.200	24	2-102241-2
2.300	1.100	1.100	23	2-102241-1
2.200	1.000	1.100	22	2-102241-0
2.100	1.000	1.000	21	1-102241-9
2.000	.900	1.000	20	1-102241-8
1.900	.900	.900	19	1-102241-7
1.800	.800	.900	18	1-102241-6
1.700	.800	.800	17	1-102241-5
1.600	.700	.800	16	1-102241-4
1.500	.700	.700	15	1-102241-3
1.400	.600	.700	14	1-102241-2
1.300	.600	.600	13	1-102241-1
1.200	.500	.600	12	1-102241-0
1.100	.500	.500	11	102241-9
1.000	.400	.500	10	102241-8
.900	.400	.400	9	102241-7
.800	.300	.400	8	102241-6
.700	.300	.300	7	102241-5
.600	.200	.300	6	102241-4
.500	.200	.200	5	102241-3
.400	.100	.200	4	102241-2
.300	.100	.100	3	102241-1

- 1 CAVITY LOCATION DIMENSIONS INCREASE IN INCREMENTS OF .100 TOLERANCE NON-CUMULATIVE
- 2 USE EXTRACTION TOOL 91052-1 TO REMOVE RECEPTACLE CONTACTS

THIS DRAWING IS A CONTROLLED DOCUMENT.

DWN D FABIAN 8-2-78	Tyco Electronics Corporation Harrisburg, PA 17105-3608
CHK B WOLFE 10-27-78	
APVD -	NAME
PRODUCT SPEC -	CONN HOUSING, CRIMP SNAP-IN MOD IV, SINGLE ROW, .100 CENTERS, WITH POLARIZATION AND DETENTS
APPLICATION SPEC -	SIZE CAGE CODE DRAWING NO RESTRICTED TO
WEIGHT -	A2 00779 C=102241
MATERIAL FLAME RETARDANT GLASS FILLED NYLON COLOR: BLACK PER ASTM D4066	CUSTOMER DRAWING SCALE SHEET 1 of 1 REV N1