

## LOW-POWER RS-485 LINE DRIVER AND RECEIVER PAIRS

### FEATURES

- Designed for High-Speed Multipoint Data Transmission Over Long Cables
- Operate With Pulse Durations as Low as 30 ns
- Low Supply Current . . . 5 mA Max
- Meet or Exceed the Requirements of ANSI Standard RS-485 and ISO 8482:1987(E)
- 3-State Outputs for Party-Line Buses
- Common-Mode Voltage Range of  $-7\text{ V}$  to  $12\text{ V}$
- Thermal Shutdown Protection Prevents Driver Damage From Bus Contention
- Positive and Negative Output Current Limiting
- Pin Compatible With the SN75ALS180

### DESCRIPTION

The SN55LBC180, SN65LBC180 and SN75LBC180 differential driver and receiver pairs are monolithic integrated circuits designed for bidirectional data communication over long cables that take on the characteristics of transmission lines. They are balanced, or differential, voltage mode devices that meet or exceed the requirements of industry standards ANSI RS-485 and ISO 8482:1987(E). These devices are designed using TI's proprietary LinBiCMOS™ with the low-power consumption of CMOS and the precision and robustness of bipolar transistors in the same circuit.

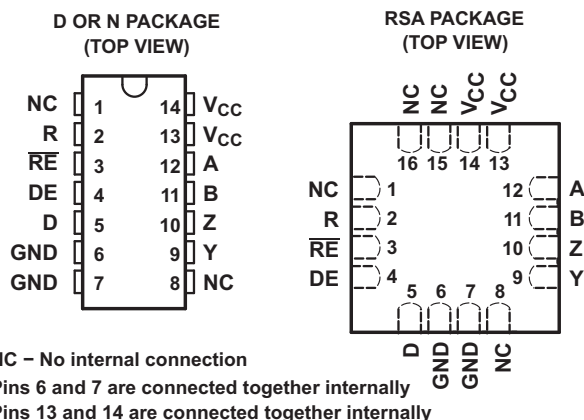

### logic diagram (positive logic)

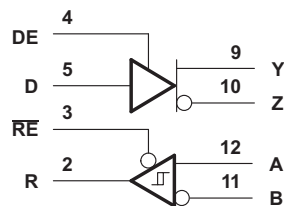

### ORDERING INFORMATION

T <sub>A</sub>	PACKAGE	PART NUMBER	PART MARKING
0°C to 70°C	PDIP	SN75LBC180N	SN75LBC180N
	SOIC	SN75LBC180D	7LB180
	QFN	SN75LBC180RSA	LB180
-40°C to 85°C	PDIP	SN65LBC180N	65LBC180N
	SOIC	SN65LBC180D	6LB180
	QFN	SN65LBC180RSA	BL180
-55°C to 125°C	QFN	SN55LBC180RSA	SN55LBC180



Please be aware that an important notice concerning availability, standard warranty, and use in critical applications of Texas Instruments semiconductor products and disclaimers thereto appears at the end of this data sheet.

LinBiCMOS is a trademark of Texas Instruments.



These devices have limited built-in ESD protection. The leads should be shorted together or the device placed in conductive foam during storage or handling to prevent electrostatic damage to the MOS gates.

## DESCRIPTION (CONTINUED)

The SN55LBC180, SN65LBC180 and SN75LBC180 combine a differential line driver and receiver with 3-state outputs and operate from a single 5-V supply. The driver and receiver have active-high and active-low enables, respectively, which can be externally connected to function as a direction control. The driver differential outputs and the receiver differential inputs are connected to separate terminals for full-duplex operation and are designed to present minimum loading to the bus whether disabled or powered off ( $V_{CC} = 0$ ). These parts feature a wide common-mode voltage range making them suitable for point-to-point or multipoint data-bus applications.

The devices also provide positive and negative output-current limiting and thermal shutdown for protection from line fault conditions. The line driver shuts down at a junction temperature of approximately 172°C.

The SN75LBC180 is characterized for operation over the commercial temperature range of 0°C to 70°C. The SN65LBC180 is characterized over the industrial temperature range of -40°C to 85°C.

The SN55LBC180 is characterized for operation over the military temperature range of -55°C to 125°C.

FUNCTION TABLES<sup>(1)</sup>

DRIVER			
INPUT D	ENABLE DE	OUTPUTS	
		Y	Z
H	H	H	L
L	H	L	H
X	L	Z	Z
RECEIVER			
DIFFERENTIAL INPUTS A-B	ENABLE RE	OUTPUT R	
$V_{ID} \geq 0.2 \text{ V}$	L	H	
$-0.2 \text{ V} < V_{ID} < 0.2 \text{ V}$	L	?	
$V_{ID} \leq -0.2 \text{ V}$	L	L	
X	H	Z	
Open circuit	L	H	

(1) H = high level, L = low level, ? = Indeterminate, X = irrelevant,  
 Z = high impedance (off)

## ABSOLUTE MAXIMUM RATINGS<sup>(1)</sup>

			UNIT	
$V_{CC}$	Supply voltage range <sup>(2)</sup>	–0.3 to 7	V	
$V_{BUS}$	Bus voltage range (A, B, Y, Z) <sup>(2)</sup>	–10 to 15	V	
	Voltage range at D, R, DE, $\overline{RE}$ <sup>(2)</sup>	–0.3 to $V_{CC} + 0.5$	V	
	Continuous total power dissipation <sup>(3)</sup>	Internally limited		
	Total power dissipation	See Dissipation Rating Table		
$T_{stg}$	Storage temperature range	–65 to 150	°C	
$I_O$	Receiver output current range	–50 to 50	mA	
ESD	Electrostatic discharge	HBM (Human Body Model) EIA/JESD22-A114	±4	kV
		MM (Machine Model) EIA/JESD22-A115	400	V
		CDM (Charge Device Model) EIA/JESD22-C101	1.5	kV

- (1) Stresses beyond those listed under *absolute maximum ratings* may cause permanent damage to the device. These are stress ratings only, and functional operation of the device at these or any other conditions beyond those indicated under *recommended operating conditions* is not implied. Exposure to absolute-maximum-rated conditions for extended periods may affect device reliability.
- (2) All voltage values are with respect to GND.
- (3) The maximum operating junction temperature is internally limited. Use the dissipation rating table to operate below this temperature.

## DISSIPATION RATING TABLE

PACKAGE <sup>(1)</sup>	$T_A \leq 25^\circ\text{C}$ POWER RATING	DERATING FACTOR ABOVE $T_A = 25^\circ\text{C}$	$T_A = 70^\circ\text{C}$ POWER RATING	$T_A = 85^\circ\text{C}$ POWER RATING	$T_A = 125^\circ\text{C}$ POWER RATING
D	950 mW	7.6 mW/°C	608 mW	494 mW	—
N	1150 mW	9.2 mW/°C	736 mW	598 mW	—
RSA	3333 mW	26.67 mW/°C	2133 mW	1733 mW	400 mW

- (1) For the most current package and ordering information, see the Package Option Addendum at the end of this document, or see the TI Web site at [www.ti.com](http://www.ti.com).

## RECOMMENDED OPERATING CONDITIONS

			MIN	NOM	MAX	UNIT
$V_{CC}$	Supply voltage		4.75	5	5.25	V
$V_{IH}$	High-level input voltage	D, DE, and $\overline{RE}$	2			V
$V_{IL}$	Low-level input voltage	D, DE, and $\overline{RE}$			0.8	V
$V_{ID}$	Differential input voltage		–6 <sup>(1)</sup>		6	V
$V_O$ , $V_I$ , or $V_{IC}$	Voltage at any bus terminal (separately or common mode)	A, B, Y, or Z	–7 <sup>(1)</sup>		12	V
$I_{OH}$	High-level output current	Y or Z			–60	mA
		R			–8	
$I_{OL}$	Low-level output current	Y or Z			60	mA
		R			8	
$T_A$	Operating free-air temperature	SN55LBC180	–55		125	°C
		SN65LBC180	–40		85	
		SN75LBC180	0		70	

- (1) The algebraic convention where the least positive (more negative) limit is designated minimum, is used in this data sheet for the differential input voltage, voltage at any bus terminal, operating temperature, input threshold voltage, and common-mode output voltage.

## DRIVER SECTION

### ELECTRICAL CHARACTERISTICS

over recommended operating conditions (unless otherwise noted)

PARAMETER		TEST CONDITIONS		MIN	TYP <sup>(1)</sup>	MAX	UNIT
$V_{IK}$	Input clamp voltage	$I_I = -18 \text{ mA}$				-1.5	V
$ V_{OD} $	Differential output voltage magnitude <sup>(2)</sup>	$R_L = 54 \Omega$ , See <a href="#">Figure 1</a>	SN55LBC180	1	2.5	5	V
			SN65LBC180	1.1	2.5	5	
			SN75LBC180	1.5	2.5	5	
		$R_L = 60 \Omega$ , See <a href="#">Figure 2</a>	SN55LBC180	1	2.5	5	
			SN65LBC180	1.1	2	5	
			SN75LBC180	1.5	2	5	
$\Delta V_{OD} $	Change in magnitude of differential output voltage <sup>(3)</sup>	See <a href="#">Figure 1</a> and <a href="#">Figure 2</a>				$\pm 0.2$	V
$V_{OC}$	Common-mode output voltage			1	2.5	3	V
$\Delta V_{OC} $	Change in magnitude of common-mode output voltage <sup>(3)</sup>	$R_L = 54 \Omega$ ,	See <a href="#">Figure 1</a>			$\pm 0.2$	V
$I_O$	Output current with power off	$V_{CC} = 0$ ,	$V_O = -7 \text{ V to } 12 \text{ V}$			$\pm 100$	$\mu\text{A}$
$I_{OZ}$	High-impedance-state output current	$V_O = -7 \text{ V to } 12 \text{ V}$				$\pm 100$	$\mu\text{A}$
$I_{IH}$	High-level input current	$V_I = 2.4 \text{ V}$				100	$\mu\text{A}$
$I_{IL}$	Low-level input current	$V_I = 0.4 \text{ V}$				100	$\mu\text{A}$
$I_{OS}$	Short-circuit output current	$-7 \text{ V} \leq V_O \leq 12 \text{ V}$				$\pm 250$	mA
$I_{CC}$	Supply current	Receiver disabled	Outputs enabled			5	mA
			Outputs disabled			3	

(1) All typical values are at  $V_{CC} = 5 \text{ V}$  and  $T_A = 25^\circ\text{C}$ .

(2) The minimum  $V_{OD}$  specification may not fully comply with ANSI RS-485 at operating temperatures below  $0^\circ\text{C}$ . System designers should take the possibly lower output signal into account in determining the maximum signal-transmission distance.

(3)  $\Delta|V_{OD}|$  and  $\Delta|V_{OC}|$  are the changes in the steady-state magnitude of  $V_{OD}$  and  $V_{OC}$ , respectively, that occur when the input is changed from a high level to a low level.

### SWITCHING CHARACTERISTICS

$V_{CC} = 5 \text{ V}$ ,  $T_A = 25^\circ\text{C}$

PARAMETER		TEST CONDITIONS		MIN	TYP	MAX	UNIT
$t_{d(OD)}$	Differential output delay time	$R_L = 54 \Omega$ ,	See <a href="#">Figure 3</a>	7	12	18	ns
$t_{t(OD)}$	Differential output transition time			5	10	20	ns
$t_{PZH}$	Output enable time to high level	$R_L = 110 \Omega$ ,	See <a href="#">Figure 4</a>			35	ns
$t_{PZL}$	Output enable time to low level	$R_L = 110 \Omega$ ,	See <a href="#">Figure 5</a>			35	ns
$t_{PHZ}$	Output disable time from high level	$R_L = 110 \Omega$ ,	See <a href="#">Figure 4</a>			50	ns
$t_{PLZ}$	Output disable time from low level	$R_L = 110 \Omega$ ,	See <a href="#">Figure 5</a>			35	ns

### SWITCHING CHARACTERISTICS (SN55LBC180)

$V_{CC} = 5 \text{ V}$ ,  $T_A = 25^\circ\text{C}$

PARAMETER		TEST CONDITIONS		MIN	TYP	MAX	UNIT
$t_{d(OD)}$	Differential output delay time	$R_L = 54 \Omega$ ,	See <a href="#">Figure 3</a>		15		ns
$t_{t(OD)}$	Differential output transition time				21		ns
$t_{PZH}$	Output enable time to high level	$R_L = 110 \Omega$ ,	See <a href="#">Figure 4</a>		32		ns
$t_{PHZ}$	Output disable time from high level				55		
$t_{PZL}$	Output enable time to low level	$R_L = 110 \Omega$ ,	See <a href="#">Figure 5</a>		32		ns
$t_{PLZ}$	Output disable time from low level				20		

## RECEIVER SECTION

### ELECTRICAL CHARACTERISTICS

over recommended operating conditions (unless otherwise noted)

PARAMETER	TEST CONDITIONS	MIN	TYP	MAX	UNIT
$V_{IT+}$ Positive-going input threshold voltage	$I_O = -8$ mA			0.2	V
$V_{IT-}$ Negative-going input threshold voltage	$I_O = 8$ mA	-0.2			V
$V_{hys}$ Hysteresis voltage ( $V_{IT+} - V_{IT-}$ )			45		mV
$V_{IK}$ Enable-input clamp voltage	$I_I = -18$ mA	-1.5			V
$V_{OH}$ High-level output voltage	$V_{ID} = 200$ mV, $I_{OH} = -8$ mA	3.5	4.5		V
$V_{OL}$ Low-level output voltage	$V_{ID} = -200$ mV, $I_{OL} = 8$ mA		0.3	0.5	V
$I_{OZ}$ High-impedance-state output current	$V_O = 0$ V to $V_{CC}$			$\pm 20$	$\mu$ A
$I_{IH}$ High-level enable-input current	$V_{IH} = 2.4$ V	-50			A
$I_{IL}$ Low-level enable-input current	$V_{IL} = 0.4$ V	-100			$\mu$ A
$I_I$ Bus input current	$V_I = 12$ V, $V_{CC} = 5$ V, Other input at 0 V		0.7	1	mA
	$V_I = 12$ V, $V_{CC} = 0$ V, Other input at 0 V		0.8	1	
	$V_I = -7$ V, $V_{CC} = 5$ V, Other input at 0 V	-0.8	-0.5		
	$V_I = -7$ V, $V_{CC} = 0$ V, Other input at 0 V	-0.8	-0.5		
$I_{CC}$ Supply current	Driver disabled	Outputs enabled		5	mA
		Outputs disabled		3	

### SWITCHING CHARACTERISTICS

 $V_{CC} = 5$  V,  $T_A = 25^\circ$ C

PARAMETER	TEST CONDITIONS	MIN	TYP	MAX	UNIT
$t_{PHL}$ Propagation delay time, high- to low-level output	$V_{ID} = -1.5$ V to 1.5 V, See <a href="#">Figure 6</a>	11	22	33	ns
$t_{PLH}$ Propagation delay time, low- to high-level output		11	22	33	ns
$t_{sk(p)}$ Pulse skew ( $ t_{PHL} - t_{PLH} $ )			3	6	ns
$t_t$ Transition time				5	8
$t_{PZH}$ Output enable time to high level	See <a href="#">Figure 7</a>			35	ns
$t_{PZL}$ Output enable time to low level				30	ns
$t_{PHZ}$ Output disable time from high level				35	ns
$t_{PLZ}$ Output disable time from low level				30	ns

### SWITCHING CHARACTERISTICS (SN55LBC180)

 $V_{CC} = 5$  V,  $T_A = 25^\circ$ C

PARAMETER	TEST CONDITIONS	MIN	TYP	MAX	UNIT
$t_{PHL}$ Propagation delay time, high- to low-level output	$V_{ID} = -1.5$ V to 1.5 V, See <a href="#">Figure 6</a>		26		ns
$t_{PLH}$ Propagation delay time, low- to high-level output			23		ns
$t_{sk(p)}$ Pulse skew ( $ t_{PHL} - t_{PLH} $ )			3		ns
$t_{sk(p)t}$ Transition time			4		ns
$t_{PZH}$ Output enable time to high level	See <a href="#">Figure 4</a>		30		ns
$t_{PHZ}$ Output disable time from high level			26		ns
$t_{PZL}$ Output enable time to low level			30		ns
$t_{PLZ}$ Output disable time from low level			30		ns

PARAMETER MEASUREMENT INFORMATION

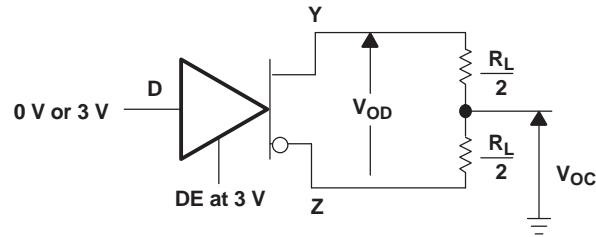

Figure 1. Differential and Common-Mode Output Voltages

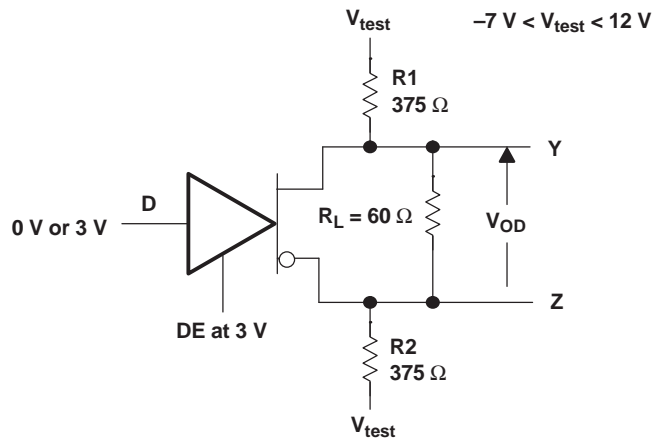
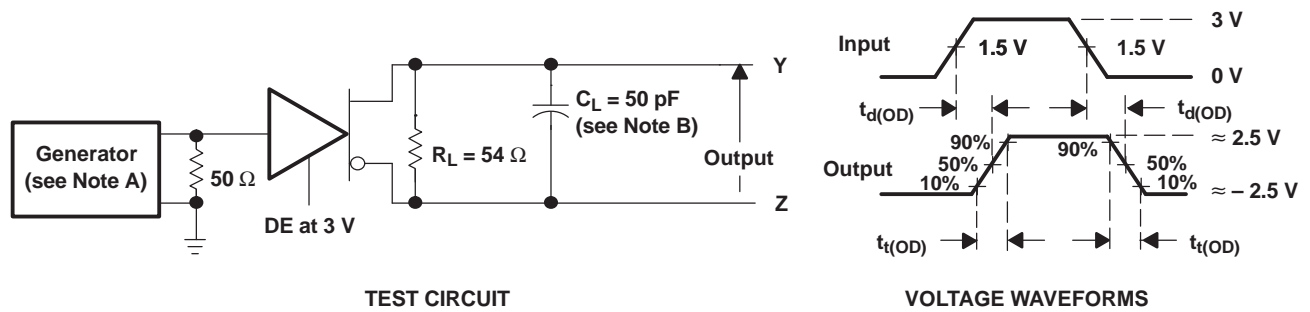

Figure 2. Driver  $V_{OD}$  Test Circuit



- NOTES: A. The input pulse is supplied by a generator having the following characteristics: PRR > 1 MHz, 50% duty cycle,  $t_r \leq 6$  ns,  $t_f \leq 6$  ns,  $Z_O = 50 \Omega$ .  
 B.  $C_L$  includes probe and jig capacitance.

Figure 3. Driver Test Circuit and Differential Output Delay and Transition Time Voltage Waveforms

PARAMETER MEASUREMENT INFORMATION (continued)

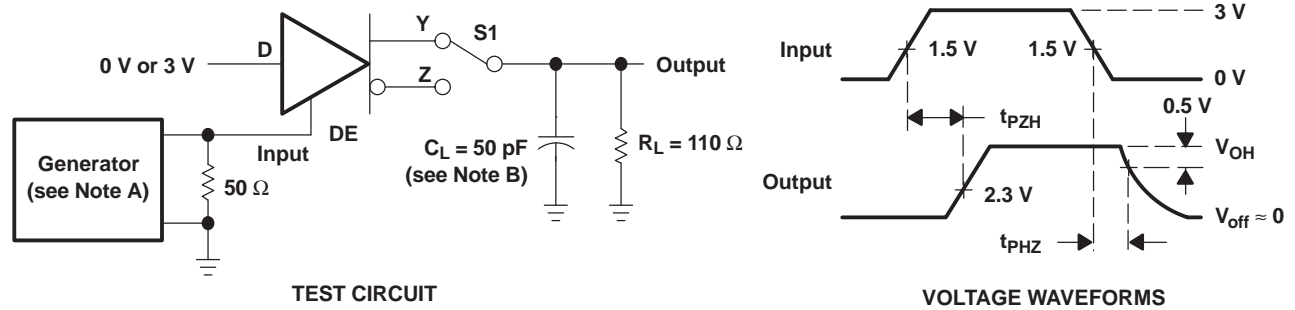

Figure 4. Driver Test Circuit and Enable and Disable Time Waveforms

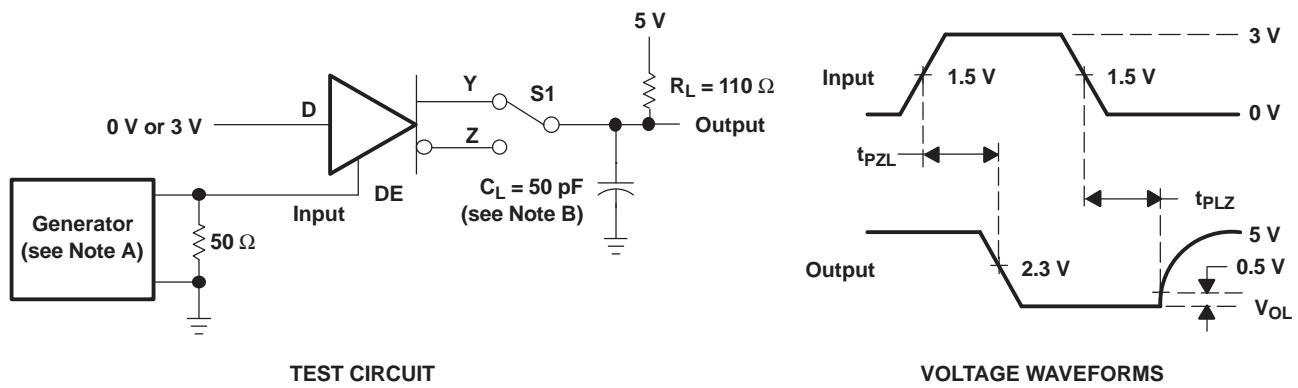
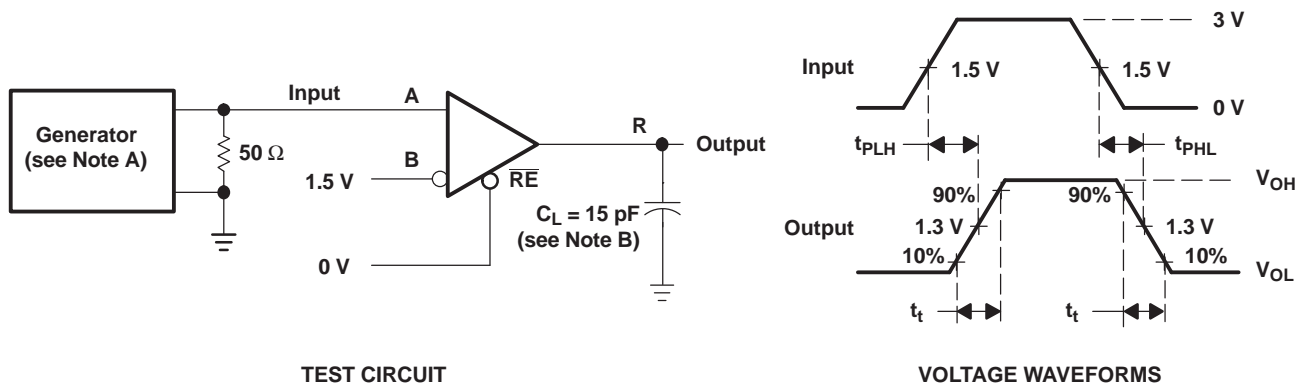

Figure 5. Driver Test Circuit and Enable and Disable Time Voltage Waveforms



- NOTES: A. The input pulse is supplied by a generator having the following characteristics: PRR ≤ 1 MHz, 50% duty cycle,  $t_r \leq 6$  ns,  $t_f \leq 6$  ns,  $Z_0 = 50 \Omega$ .  
B.  $C_L$  includes probe and jig capacitance.

Figure 6. Receiver Test Circuit and Propagation Delay Time Voltage Waveforms

PARAMETER MEASUREMENT INFORMATION (continued)

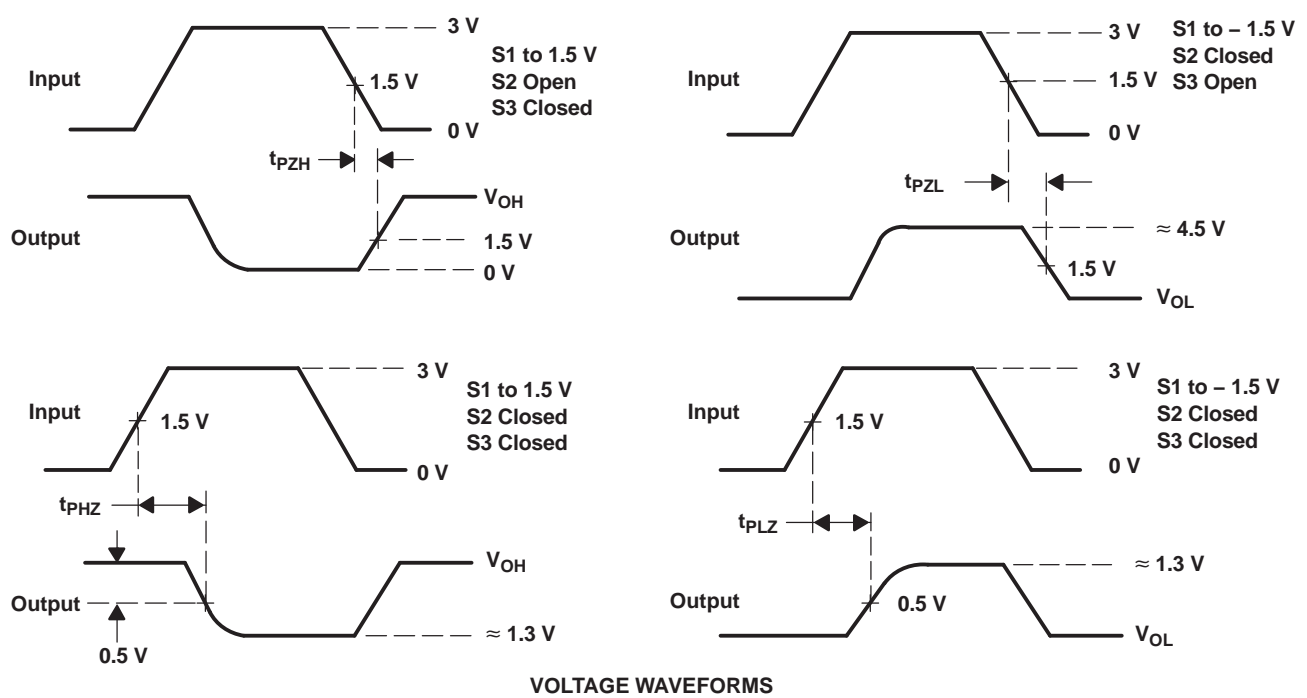
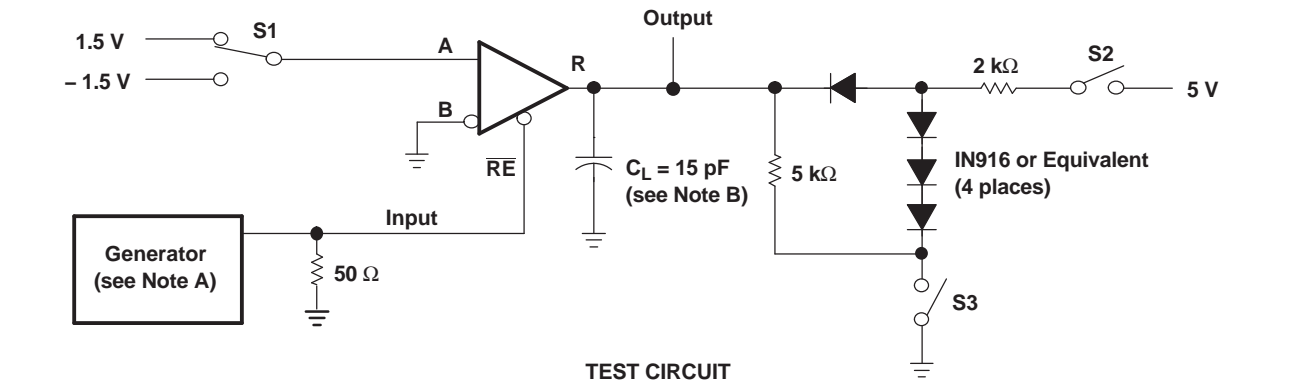

NOTES: A. The input pulse is supplied by a generator having the following characteristics: PRR  $\leq$  1 MHz, 50% duty cycle,  $t_r \leq$  6 ns,  $t_f \leq$  6 ns,  $Z_O = 50 \Omega$ .  
 B.  $C_L$  includes probe and jig capacitance.

Figure 7. Receiver Output Enable and Disable Times



TYPICAL CHARACTERISTICS

SCHEMATICS OF INPUTS AND OUTPUTS

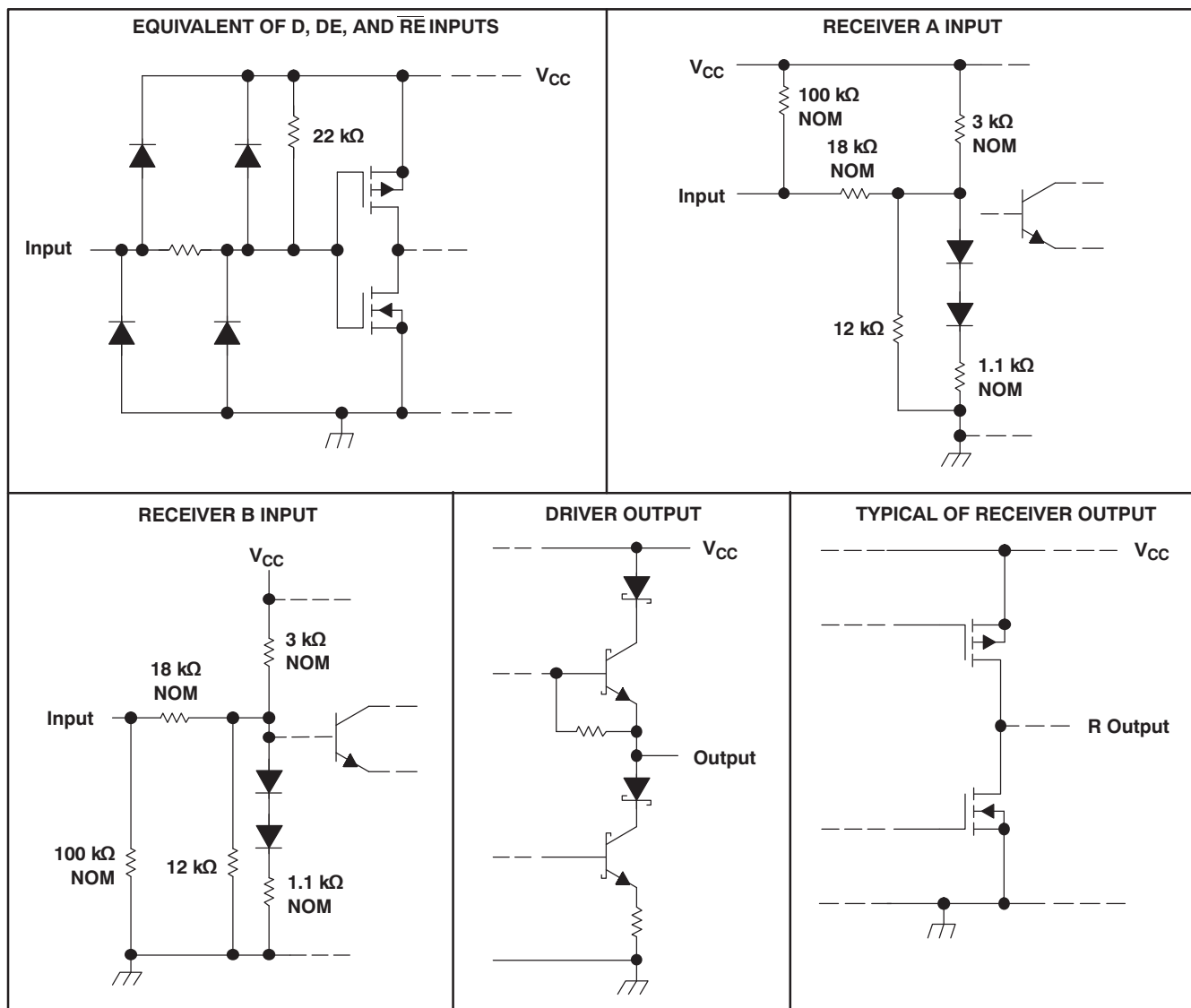

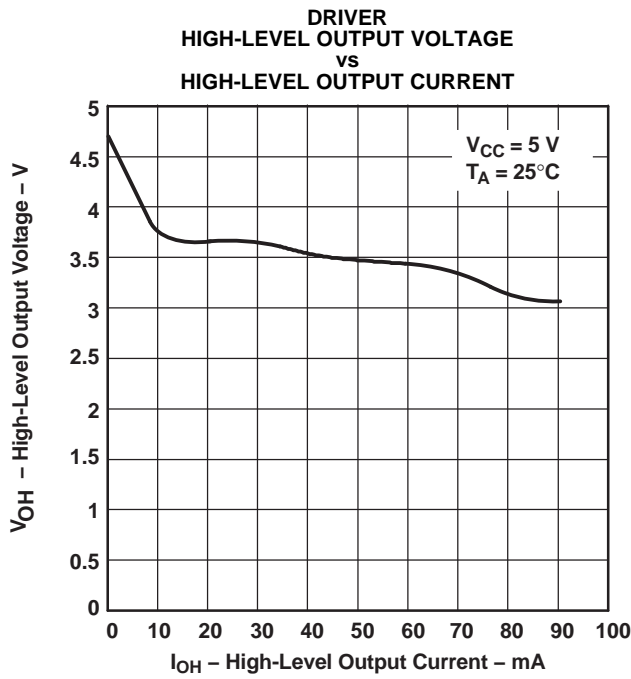

Figure 8.

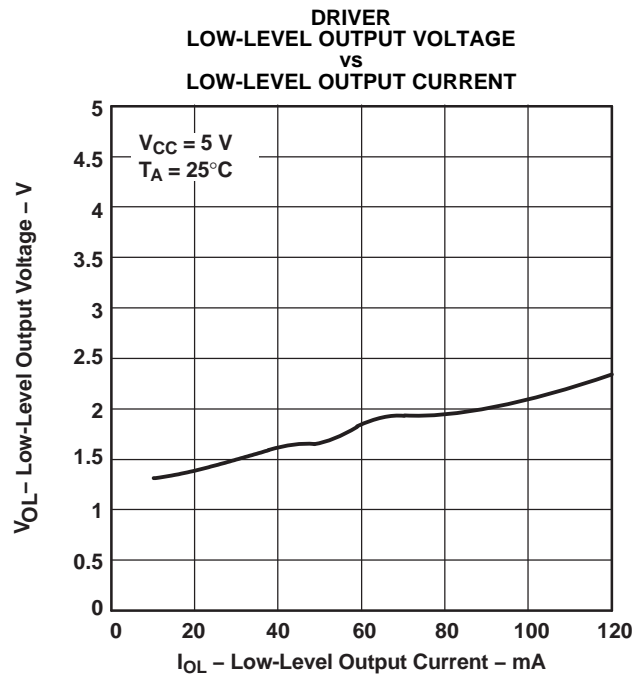

Figure 9.

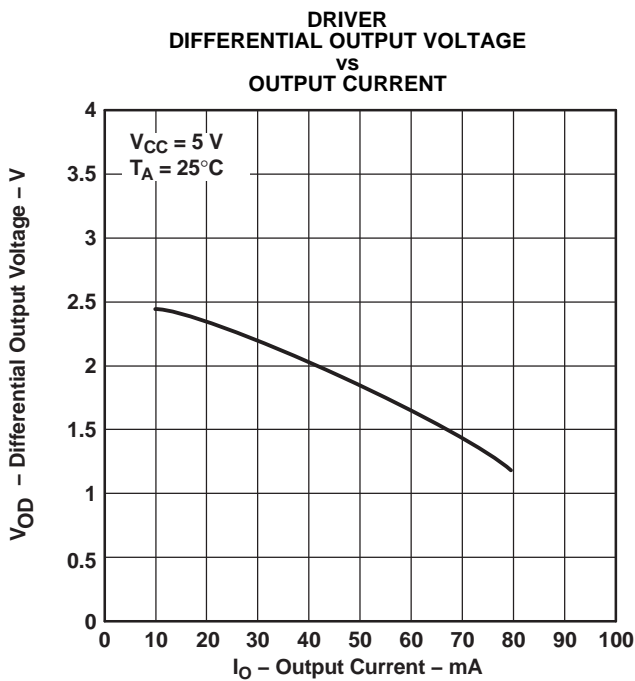

Figure 10.

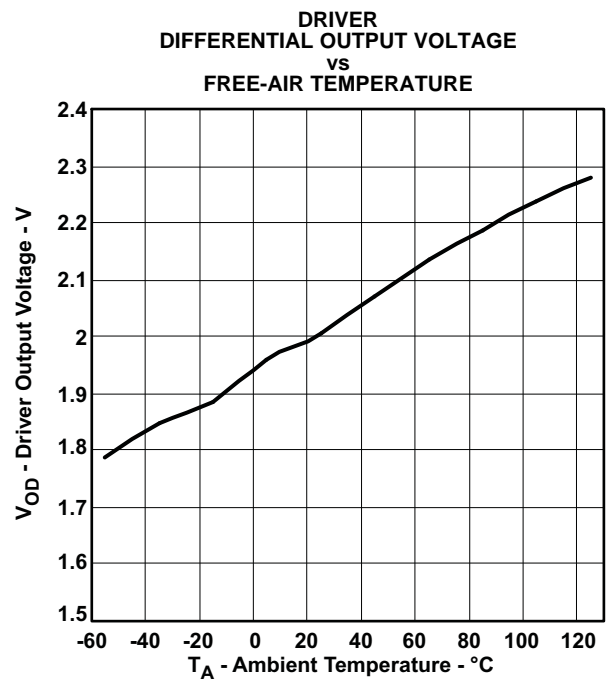

Figure 11.

DRIVER DIFFERENTIAL DELAY TIMES vs FREE-AIR TEMPERATURE

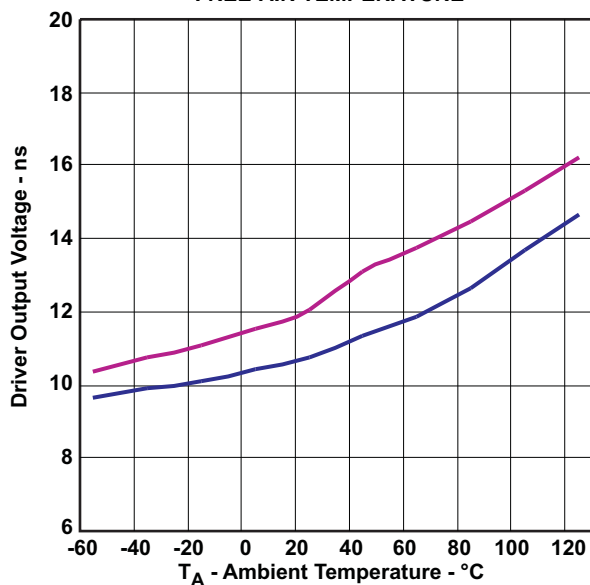

Figure 12.

DRIVER OUTPUT CURRENT vs SUPPLY VOLTAGE

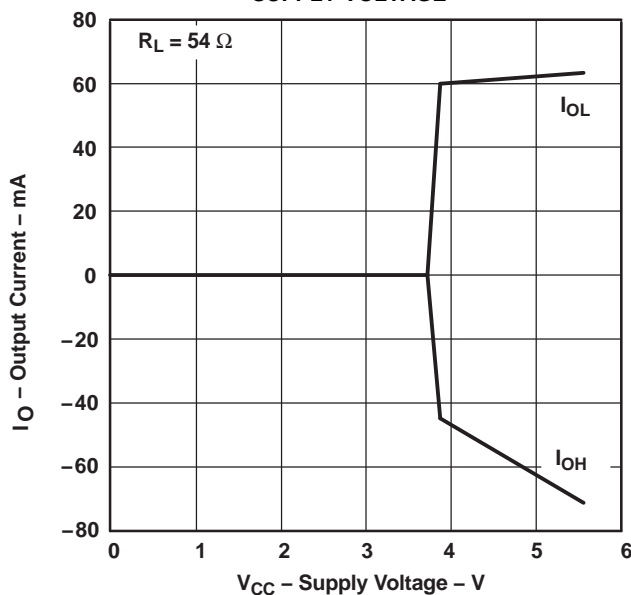

Figure 13.

RECEIVER HIGH-LEVEL OUTPUT VOLTAGE vs HIGH-LEVEL OUTPUT CURRENT

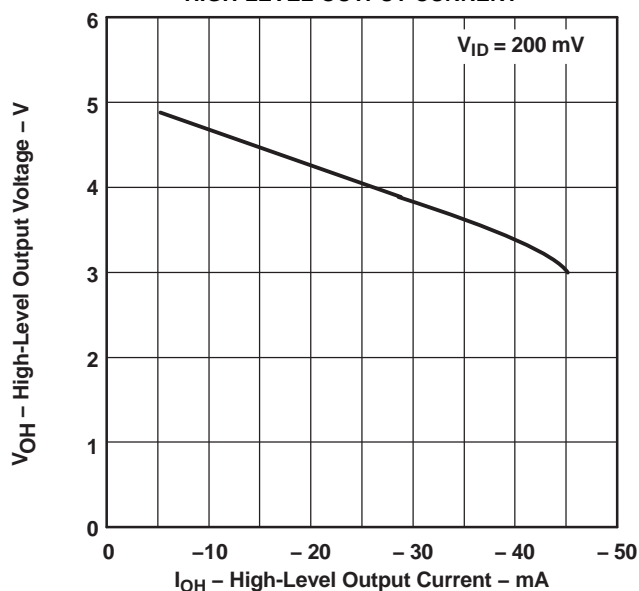

Figure 14.

RECEIVER LOW-LEVEL OUTPUT VOLTAGE vs LOW-LEVEL OUTPUT CURRENT

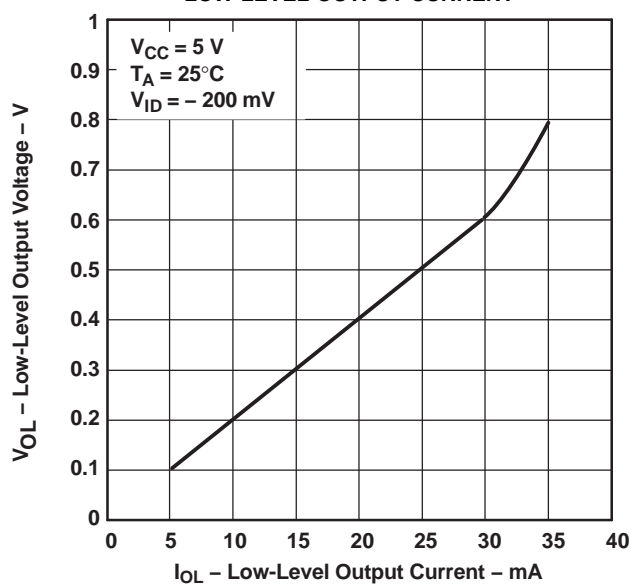
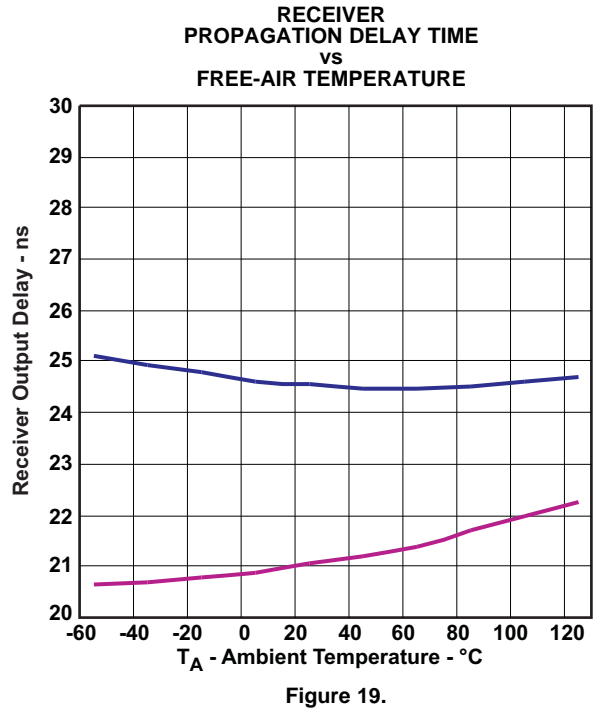
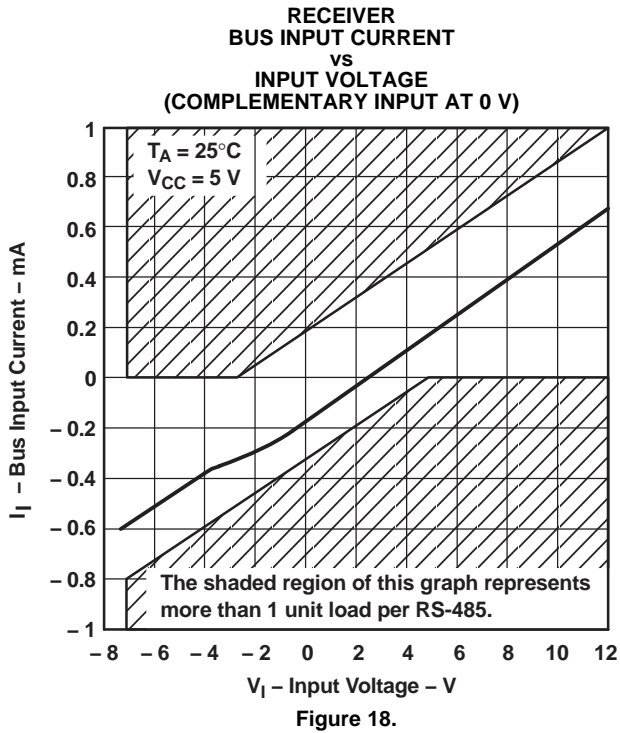
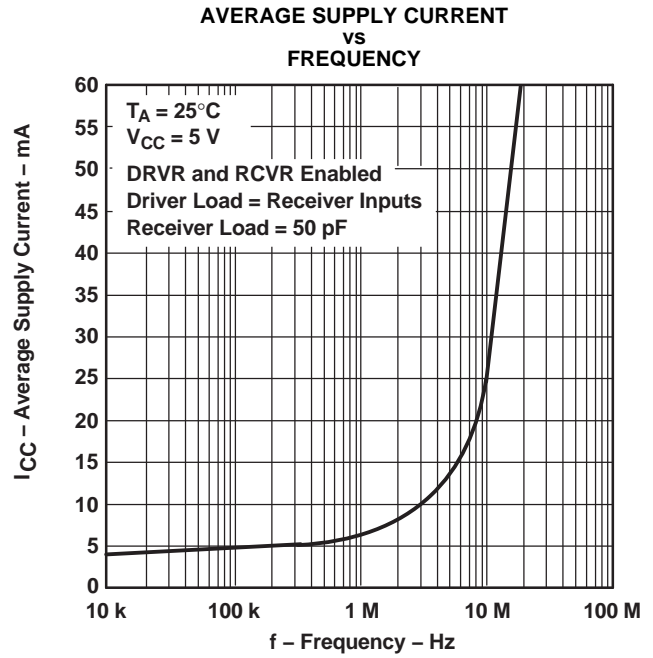
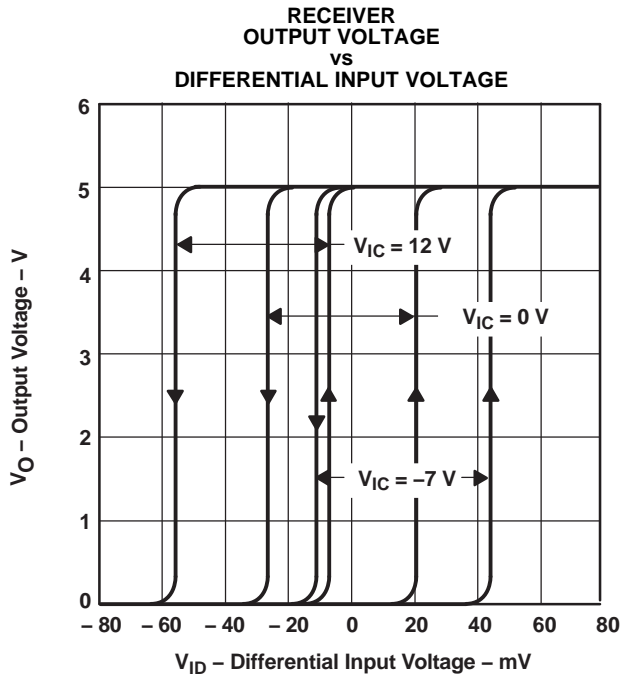

Figure 15.



### APPLICATION INFORMATION

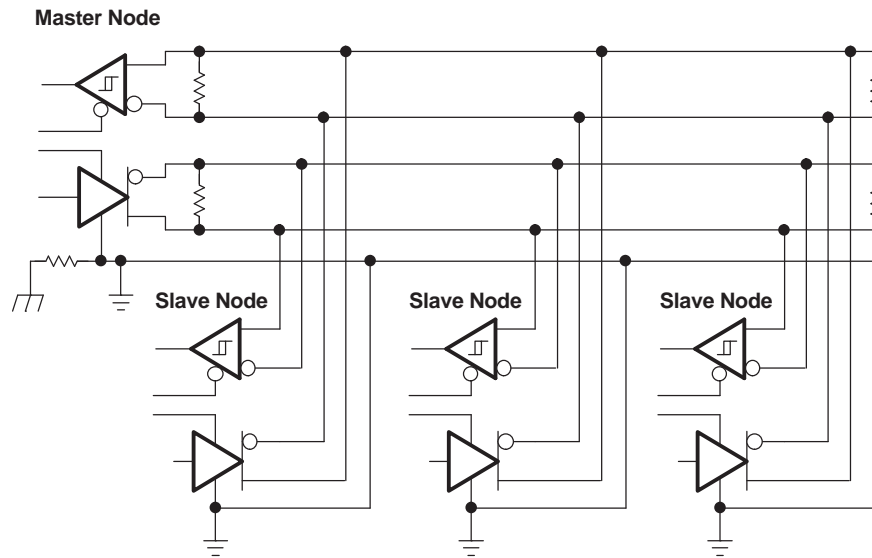

Figure 20. Full Duplex Application Circuit

**PACKAGING INFORMATION**

Orderable Device	Status <sup>(1)</sup>	Package Type	Package Drawing	Pins	Package Qty	Eco Plan <sup>(2)</sup>	Lead/Ball Finish	MSL Peak Temp <sup>(3)</sup>
SN55LBC180RSAR	ACTIVE	QFN	RSA	16	3000	Green (RoHS & no Sb/Br)	CU NIPDAU	Level-2-260C-1 YEAR
SN55LBC180RSAT	ACTIVE	QFN	RSA	16	250	Green (RoHS & no Sb/Br)	CU NIPDAU	Level-2-260C-1 YEAR
SN65LBC180D	ACTIVE	SOIC	D	14	50	Green (RoHS & no Sb/Br)	CU NIPDAU	Level-1-260C-UNLIM
SN65LBC180DG4	ACTIVE	SOIC	D	14	50	Green (RoHS & no Sb/Br)	CU NIPDAU	Level-1-260C-UNLIM
SN65LBC180DR	ACTIVE	SOIC	D	14	2500	Green (RoHS & no Sb/Br)	CU NIPDAU	Level-1-260C-UNLIM
SN65LBC180DRG4	ACTIVE	SOIC	D	14	2500	Green (RoHS & no Sb/Br)	CU NIPDAU	Level-1-260C-UNLIM
SN65LBC180N	ACTIVE	PDIP	N	14	25	Pb-Free (RoHS)	CU NIPDAU	N / A for Pkg Type
SN65LBC180NE4	ACTIVE	PDIP	N	14	25	Pb-Free (RoHS)	CU NIPDAU	N / A for Pkg Type
SN65LBC180RSAR	ACTIVE	QFN	RSA	16	3000	Green (RoHS & no Sb/Br)	CU NIPDAU	Level-2-260C-1 YEAR
SN65LBC180RSARG4	ACTIVE	QFN	RSA	16	3000	Green (RoHS & no Sb/Br)	CU NIPDAU	Level-2-260C-1 YEAR
SN65LBC180RSAT	ACTIVE	QFN	RSA	16	250	Green (RoHS & no Sb/Br)	CU NIPDAU	Level-2-260C-1 YEAR
SN65LBC180RSATG4	ACTIVE	QFN	RSA	16	250	Green (RoHS & no Sb/Br)	CU NIPDAU	Level-2-260C-1 YEAR
SN75LBC180D	ACTIVE	SOIC	D	14	50	Green (RoHS & no Sb/Br)	CU NIPDAU	Level-1-260C-UNLIM
SN75LBC180DG4	ACTIVE	SOIC	D	14	50	Green (RoHS & no Sb/Br)	CU NIPDAU	Level-1-260C-UNLIM
SN75LBC180DR	ACTIVE	SOIC	D	14	2500	Green (RoHS & no Sb/Br)	CU NIPDAU	Level-1-260C-UNLIM
SN75LBC180DRG4	ACTIVE	SOIC	D	14	2500	Green (RoHS & no Sb/Br)	CU NIPDAU	Level-1-260C-UNLIM
SN75LBC180N	ACTIVE	PDIP	N	14	25	Pb-Free (RoHS)	CU NIPDAU	N / A for Pkg Type
SN75LBC180NE4	ACTIVE	PDIP	N	14	25	Pb-Free (RoHS)	CU NIPDAU	N / A for Pkg Type
SN75LBC180RSAR	ACTIVE	QFN	RSA	16	3000	Green (RoHS & no Sb/Br)	CU NIPDAU	Level-2-260C-1 YEAR
SN75LBC180RSARG4	ACTIVE	QFN	RSA	16	3000	Green (RoHS & no Sb/Br)	CU NIPDAU	Level-2-260C-1 YEAR
SN75LBC180RSAT	ACTIVE	QFN	RSA	16	250	Green (RoHS & no Sb/Br)	CU NIPDAU	Level-2-260C-1 YEAR
SN75LBC180RSATG4	ACTIVE	QFN	RSA	16	250	Green (RoHS & no Sb/Br)	CU NIPDAU	Level-2-260C-1 YEAR

<sup>(1)</sup> The marketing status values are defined as follows:

**ACTIVE:** Product device recommended for new designs.

**LIFEBUY:** TI has announced that the device will be discontinued, and a lifetime-buy period is in effect.

**NRND:** Not recommended for new designs. Device is in production to support existing customers, but TI does not recommend using this part in a new design.

**PREVIEW:** Device has been announced but is not in production. Samples may or may not be available.

**OBSOLETE:** TI has discontinued the production of the device.

<sup>(2)</sup> Eco Plan - The planned eco-friendly classification: Pb-Free (RoHS), Pb-Free (RoHS Exempt), or Green (RoHS & no Sb/Br) - please check <http://www.ti.com/productcontent> for the latest availability information and additional product content details.

**TBD:** The Pb-Free/Green conversion plan has not been defined.

**Pb-Free (RoHS):** TI's terms "Lead-Free" or "Pb-Free" mean semiconductor products that are compatible with the current RoHS requirements for all 6 substances, including the requirement that lead not exceed 0.1% by weight in homogeneous materials. Where designed to be soldered at high temperatures, TI Pb-Free products are suitable for use in specified lead-free processes.

**Pb-Free (RoHS Exempt):** This component has a RoHS exemption for either 1) lead-based flip-chip solder bumps used between the die and package, or 2) lead-based die adhesive used between the die and leadframe. The component is otherwise considered Pb-Free (RoHS compatible) as defined above.

**Green (RoHS & no Sb/Br):** TI defines "Green" to mean Pb-Free (RoHS compatible), and free of Bromine (Br) and Antimony (Sb) based flame retardants (Br or Sb do not exceed 0.1% by weight in homogeneous material)

<sup>(3)</sup> MSL, Peak Temp. -- The Moisture Sensitivity Level rating according to the JEDEC industry standard classifications, and peak solder temperature.

**Important Information and Disclaimer:**The information provided on this page represents TI's knowledge and belief as of the date that it is provided. TI bases its knowledge and belief on information provided by third parties, and makes no representation or warranty as to the accuracy of such information. Efforts are underway to better integrate information from third parties. TI has taken and continues to take reasonable steps to provide representative and accurate information but may not have conducted destructive testing or chemical analysis on incoming materials and chemicals. TI and TI suppliers consider certain information to be proprietary, and thus CAS numbers and other limited information may not be available for release.

In no event shall TI's liability arising out of such information exceed the total purchase price of the TI part(s) at issue in this document sold by TI to Customer on an annual basis.

**OTHER QUALIFIED VERSIONS OF SN55LBC180, SN65LBC180, SN75LBC180 :**

- Automotive: [SN65LBC180-Q1](#)

NOTE: Qualified Version Definitions:

- Automotive - Q100 devices qualified for high-reliability automotive applications targeting zero defects

**TAPE AND REEL INFORMATION**

**QUADRANT ASSIGNMENTS FOR PIN 1 ORIENTATION IN TAPE**

\*All dimensions are nominal

Device	Package Type	Package Drawing	Pins	SPQ	Reel Diameter (mm)	Reel Width W1 (mm)	A0 (mm)	B0 (mm)	K0 (mm)	P1 (mm)	W (mm)	Pin1 Quadrant
SN55LBC180RSAR	QFN	RSA	16	3000	330.0	12.4	4.25	4.25	1.15	8.0	12.0	Q2
SN55LBC180RSAT	QFN	RSA	16	250	180.0	12.4	4.25	4.25	1.15	8.0	12.0	Q2
SN65LBC180DR	SOIC	D	14	2500	330.0	16.4	6.5	9.0	2.1	8.0	16.0	Q1
SN65LBC180RSAR	QFN	RSA	16	3000	330.0	12.4	4.25	4.25	1.15	8.0	12.0	Q2
SN65LBC180RSAT	QFN	RSA	16	250	180.0	12.4	4.25	4.25	1.15	8.0	12.0	Q2
SN75LBC180DR	SOIC	D	14	2500	330.0	16.4	6.5	9.0	2.1	8.0	16.0	Q1
SN75LBC180RSAR	QFN	RSA	16	3000	330.0	12.4	4.25	4.25	1.15	8.0	12.0	Q2
SN75LBC180RSAT	QFN	RSA	16	250	180.0	12.4	4.25	4.25	1.15	8.0	12.0	Q2



**TAPE AND REEL BOX DIMENSIONS**



\*All dimensions are nominal

Device	Package Type	Package Drawing	Pins	SPQ	Length (mm)	Width (mm)	Height (mm)
SN55LBC180RSAR	QFN	RSA	16	3000	346.0	346.0	29.0
SN55LBC180RSAT	QFN	RSA	16	250	190.5	212.7	31.8
SN65LBC180DR	SOIC	D	14	2500	333.2	345.9	28.6
SN65LBC180RSAR	QFN	RSA	16	3000	346.0	346.0	29.0
SN65LBC180RSAT	QFN	RSA	16	250	190.5	212.7	31.8
SN75LBC180DR	SOIC	D	14	2500	333.2	345.9	28.6
SN75LBC180RSAR	QFN	RSA	16	3000	346.0	346.0	29.0
SN75LBC180RSAT	QFN	RSA	16	250	190.5	212.7	31.8

N (R-PDIP-T\*\*)

PLASTIC DUAL-IN-LINE PACKAGE

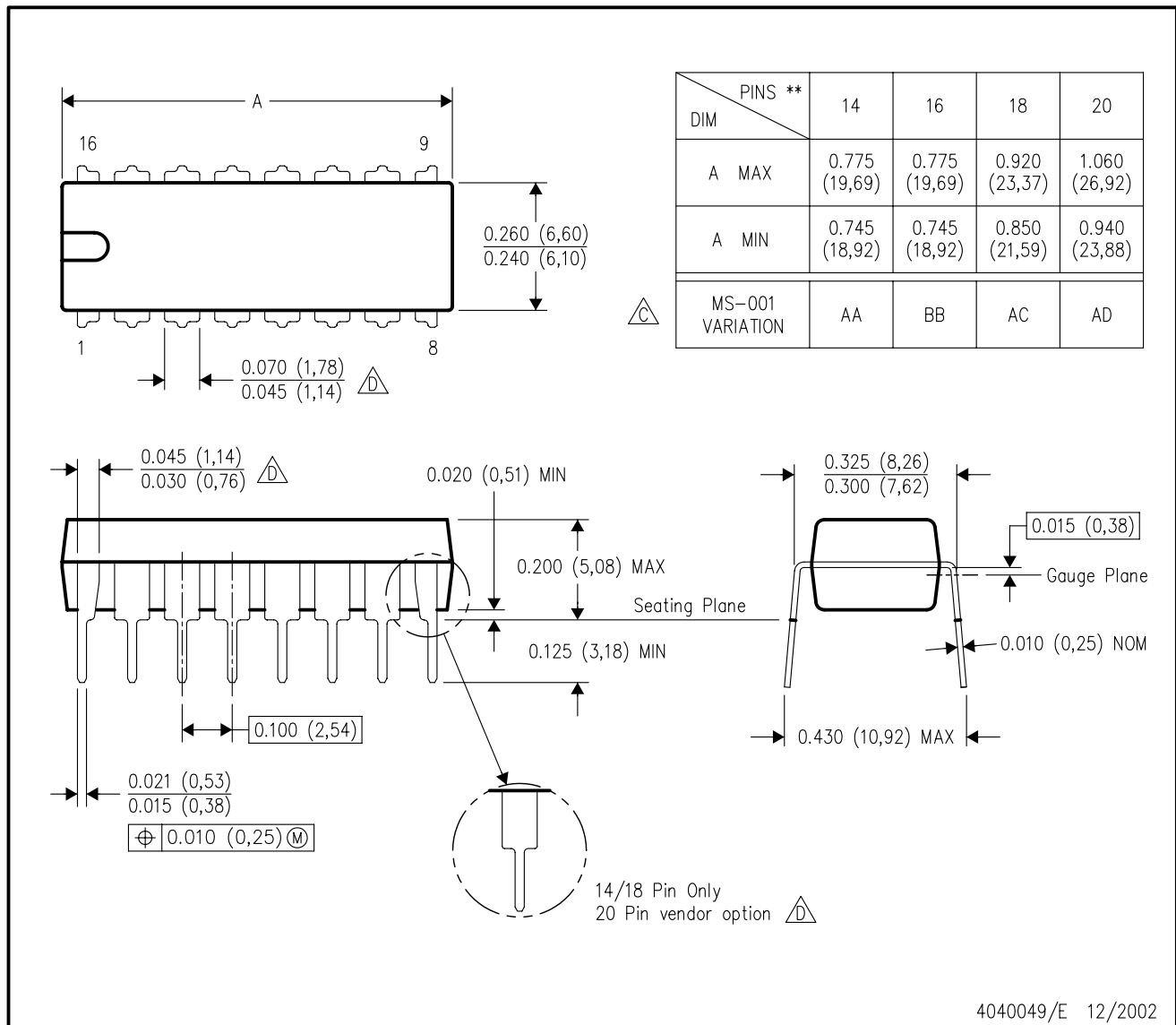
16 PINS SHOWN



- NOTES:
- A. All linear dimensions are in inches (millimeters).
  - B. This drawing is subject to change without notice.
  - C Falls within JEDEC MS-001, except 18 and 20 pin minimum body length (Dim A).
  - D The 20 pin end lead shoulder width is a vendor option, either half or full width.

4040049/E 12/2002

D (R-PDSO-G14)

PLASTIC SMALL-OUTLINE PACKAGE

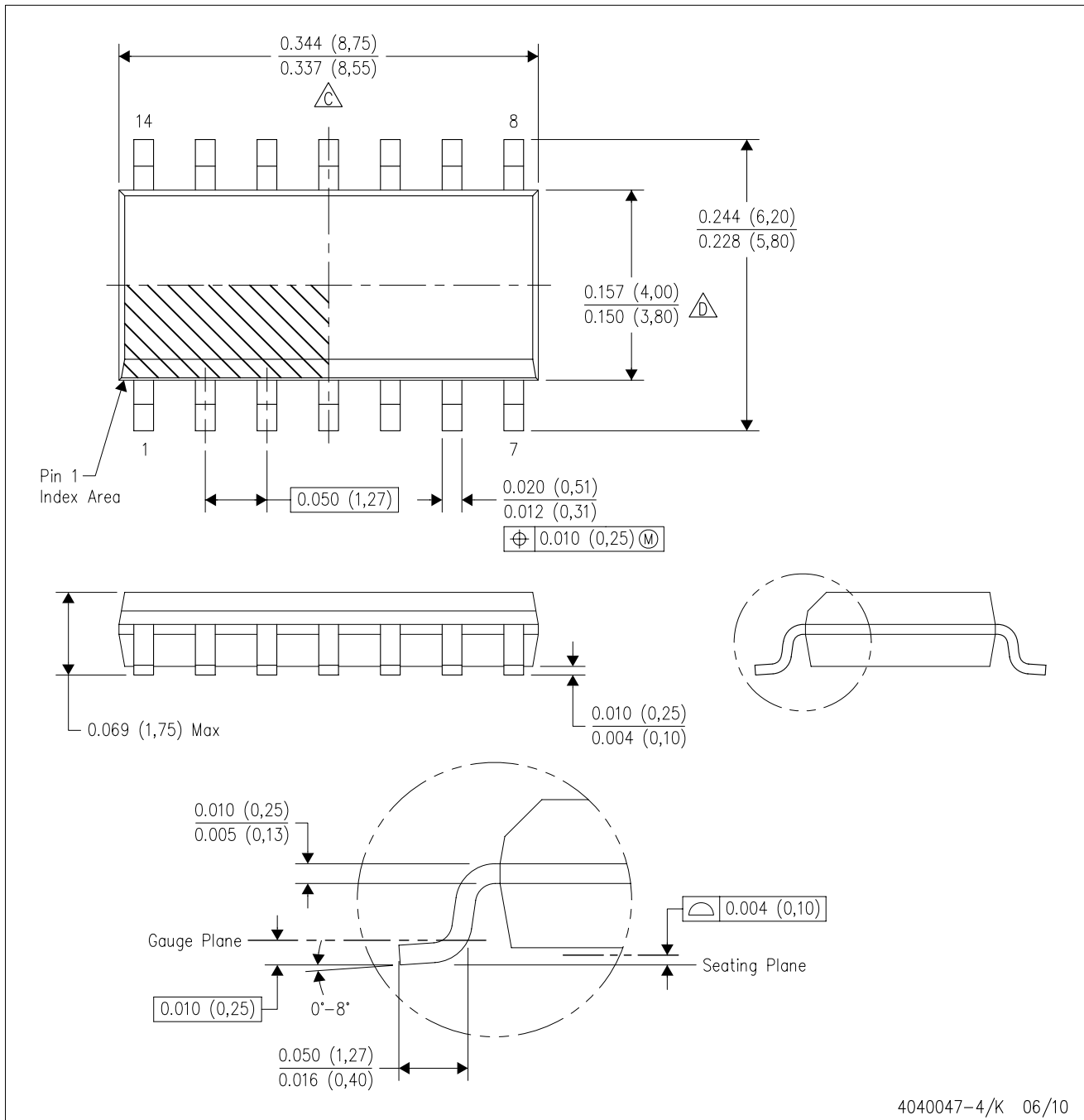

4040047-4/K 06/10

- NOTES:
- A. All linear dimensions are in inches (millimeters).
  - B. This drawing is subject to change without notice.
  - $\triangle C$  Body length does not include mold flash, protrusions, or gate burrs. Mold flash, protrusions, or gate burrs shall not exceed .006 (0,15) per end.
  - $\triangle D$  Body width does not include interlead flash. Interlead flash shall not exceed .017 (0,43) per side.
  - E. Reference JEDEC MS-012 variation AB.

RSA (S-PQFP-N16)

PLASTIC QUAD FLATPACK

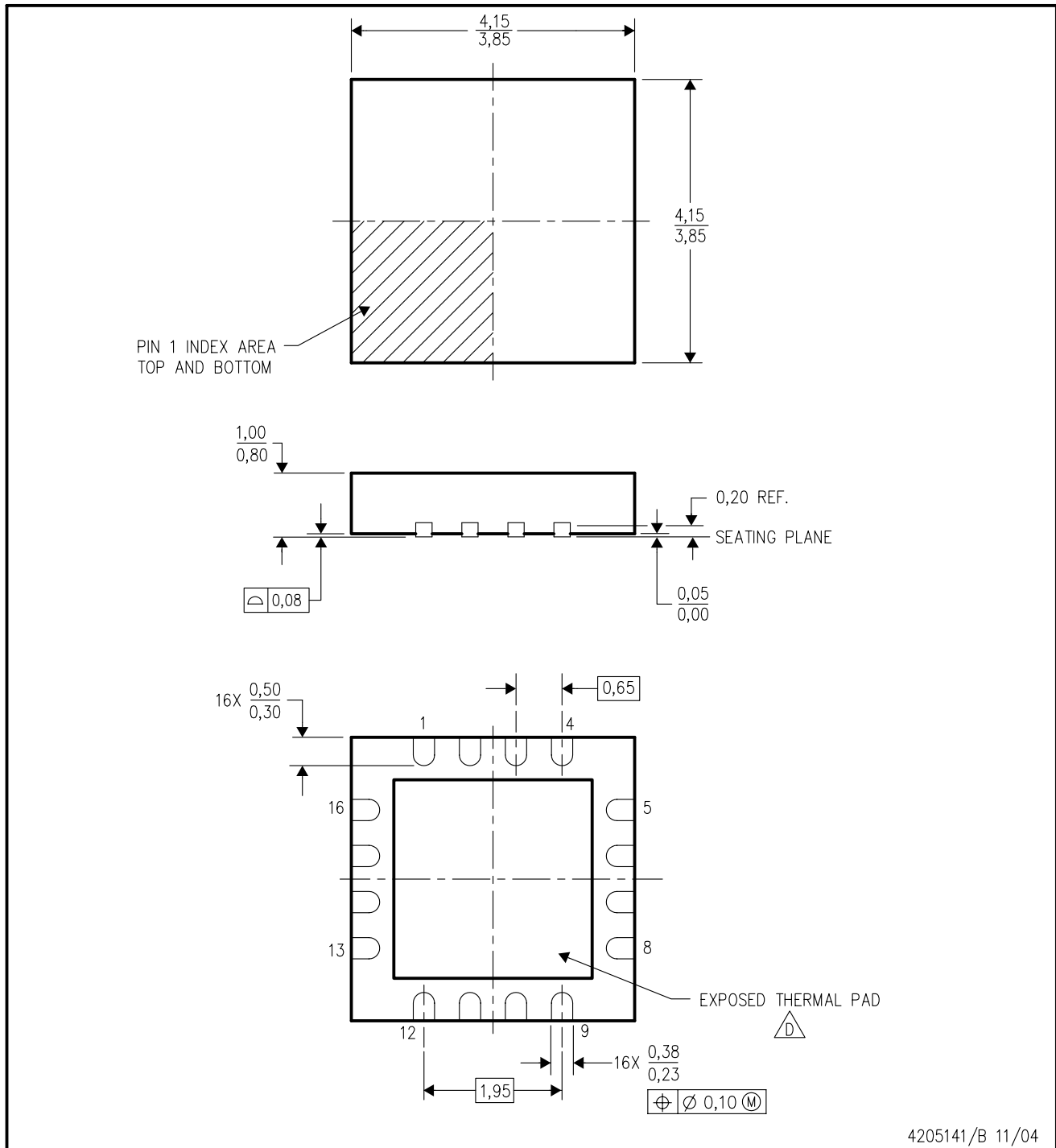

- NOTES:
- A. All linear dimensions are in millimeters. Dimensioning and tolerancing per ASME Y14.5M-1994.
  - B. This drawing is subject to change without notice.
  - C. Quad Flatpack, No-leads (QFN) package configuration.
  - $\triangle$  D The package thermal pad must be soldered to the board for thermal and mechanical performance. See the Product Data Sheet for details regarding the exposed thermal pad dimensions.
  - E. Falls within JEDEC MO-220.

**THERMAL INFORMATION**

This package incorporates an exposed thermal pad that is designed to be attached directly to an external heatsink. The thermal pad must be soldered directly to the printed circuit board (PCB). After soldering, the PCB can be used as a heatsink. In addition, through the use of thermal vias, the thermal pad can be attached directly to the appropriate copper plane shown in the electrical schematic for the device, or alternatively, can be attached to a special heatsink structure designed into the PCB. This design optimizes the heat transfer from the integrated circuit (IC).

For information on the Quad Flatpack No-Lead (QFN) package and its advantages, refer to Application Report, QFN/SON PCB Attachment, Texas Instruments Literature No. SLUA271. This document is available at [www.ti.com](http://www.ti.com).

The exposed thermal pad dimensions for this package are shown in the following illustration.

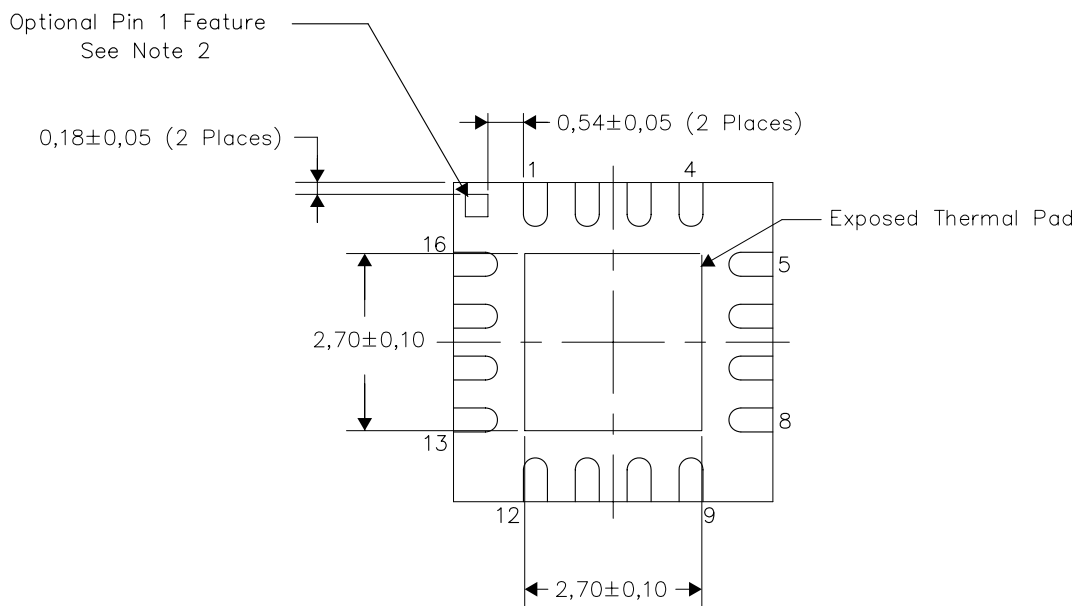

Bottom View  
Exposed Thermal Pad Dimensions

**NOTES:**

- 1) All linear dimensions are in millimeters
- 2) The Pin 1 Identification mark is an optional feature that may be present on some devices. In addition, this Pin 1 feature if present is electrically connected to the center thermal pad and therefore should be considered when routing the board layout.

RSA (S-PVQFN-N16)

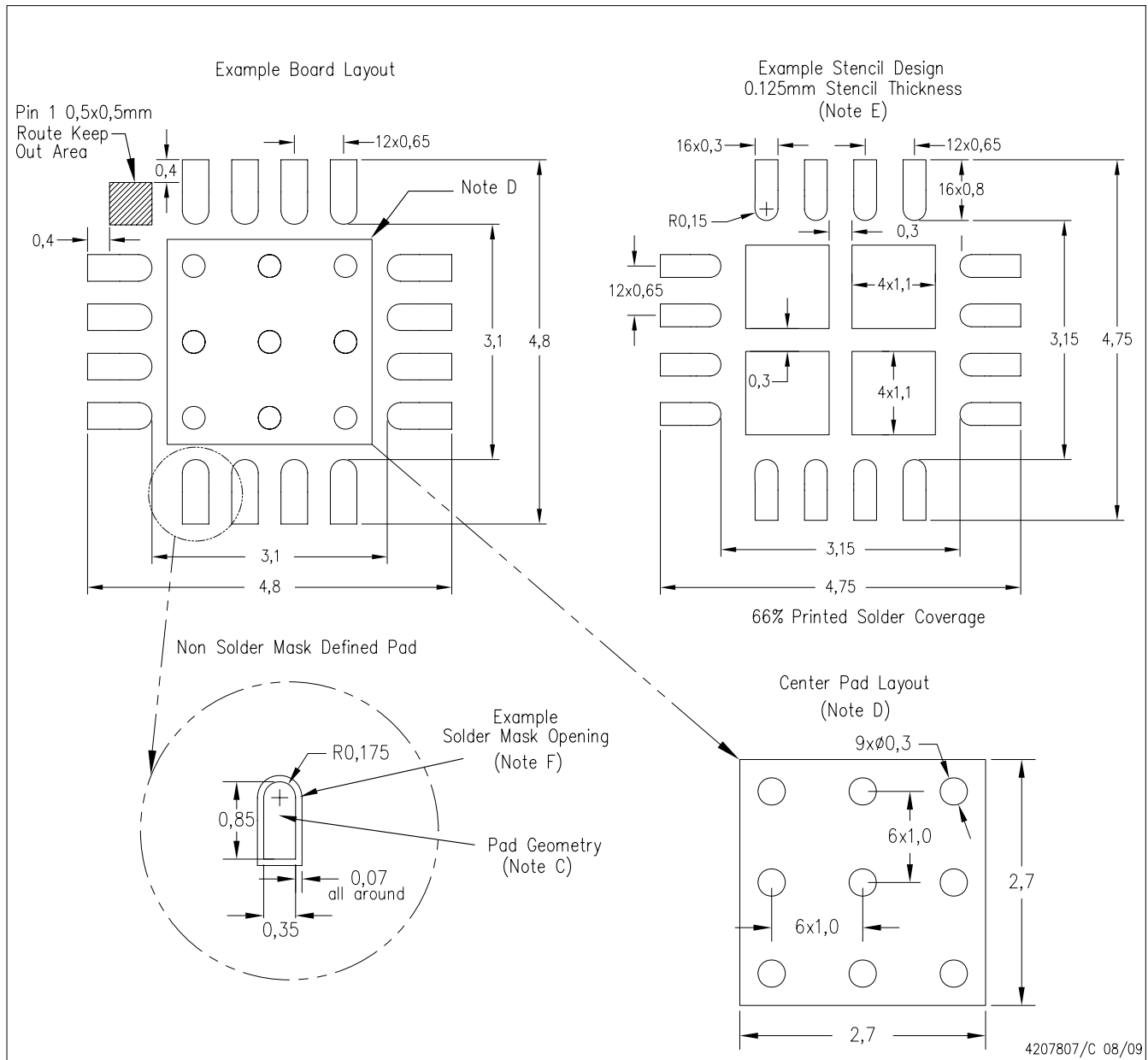

- NOTES:
- A. All linear dimensions are in millimeters.
  - B. This drawing is subject to change without notice.
  - C. Publication IPC-7351 is recommended for alternate designs.
  - D. This package is designed to be soldered to a thermal pad on the board. Refer to Application Note, QFN Packages, Texas Instruments Literature No. SLUA271, and also the Product Data Sheets for specific thermal information, via requirements, and recommended board layout. These documents are available at [www.ti.com](http://www.ti.com) <<http://www.ti.com>>.
  - E. Laser cutting apertures with trapezoidal walls and also rounding corners will offer better paste release. Customers should contact their board assembly site for stencil design recommendations. Refer to IPC 7525 for stencil design considerations.
  - F. Customers should contact their board fabrication site for solder mask tolerances.

## IMPORTANT NOTICE

Texas Instruments Incorporated and its subsidiaries (TI) reserve the right to make corrections, modifications, enhancements, improvements, and other changes to its products and services at any time and to discontinue any product or service without notice. Customers should obtain the latest relevant information before placing orders and should verify that such information is current and complete. All products are sold subject to TI's terms and conditions of sale supplied at the time of order acknowledgment.

TI warrants performance of its hardware products to the specifications applicable at the time of sale in accordance with TI's standard warranty. Testing and other quality control techniques are used to the extent TI deems necessary to support this warranty. Except where mandated by government requirements, testing of all parameters of each product is not necessarily performed.

TI assumes no liability for applications assistance or customer product design. Customers are responsible for their products and applications using TI components. To minimize the risks associated with customer products and applications, customers should provide adequate design and operating safeguards.

TI does not warrant or represent that any license, either express or implied, is granted under any TI patent right, copyright, mask work right, or other TI intellectual property right relating to any combination, machine, or process in which TI products or services are used. Information published by TI regarding third-party products or services does not constitute a license from TI to use such products or services or a warranty or endorsement thereof. Use of such information may require a license from a third party under the patents or other intellectual property of the third party, or a license from TI under the patents or other intellectual property of TI.

Reproduction of TI information in TI data books or data sheets is permissible only if reproduction is without alteration and is accompanied by all associated warranties, conditions, limitations, and notices. Reproduction of this information with alteration is an unfair and deceptive business practice. TI is not responsible or liable for such altered documentation. Information of third parties may be subject to additional restrictions.

Resale of TI products or services with statements different from or beyond the parameters stated by TI for that product or service voids all express and any implied warranties for the associated TI product or service and is an unfair and deceptive business practice. TI is not responsible or liable for any such statements.

TI products are not authorized for use in safety-critical applications (such as life support) where a failure of the TI product would reasonably be expected to cause severe personal injury or death, unless officers of the parties have executed an agreement specifically governing such use. Buyers represent that they have all necessary expertise in the safety and regulatory ramifications of their applications, and acknowledge and agree that they are solely responsible for all legal, regulatory and safety-related requirements concerning their products and any use of TI products in such safety-critical applications, notwithstanding any applications-related information or support that may be provided by TI. Further, Buyers must fully indemnify TI and its representatives against any damages arising out of the use of TI products in such safety-critical applications.

TI products are neither designed nor intended for use in military/aerospace applications or environments unless the TI products are specifically designated by TI as military-grade or "enhanced plastic." Only products designated by TI as military-grade meet military specifications. Buyers acknowledge and agree that any such use of TI products which TI has not designated as military-grade is solely at the Buyer's risk, and that they are solely responsible for compliance with all legal and regulatory requirements in connection with such use.

TI products are neither designed nor intended for use in automotive applications or environments unless the specific TI products are designated by TI as compliant with ISO/TS 16949 requirements. Buyers acknowledge and agree that, if they use any non-designated products in automotive applications, TI will not be responsible for any failure to meet such requirements.

Following are URLs where you can obtain information on other Texas Instruments products and application solutions:

<b>Products</b>		<b>Applications</b>	
Amplifiers	<a href="http://amplifier.ti.com">amplifier.ti.com</a>	Audio	<a href="http://www.ti.com/audio">www.ti.com/audio</a>
Data Converters	<a href="http://dataconverter.ti.com">dataconverter.ti.com</a>	Automotive	<a href="http://www.ti.com/automotive">www.ti.com/automotive</a>
DLP® Products	<a href="http://www.dlp.com">www.dlp.com</a>	Communications and Telecom	<a href="http://www.ti.com/communications">www.ti.com/communications</a>
DSP	<a href="http://dsp.ti.com">dsp.ti.com</a>	Computers and Peripherals	<a href="http://www.ti.com/computers">www.ti.com/computers</a>
Clocks and Timers	<a href="http://www.ti.com/clocks">www.ti.com/clocks</a>	Consumer Electronics	<a href="http://www.ti.com/consumer-apps">www.ti.com/consumer-apps</a>
Interface	<a href="http://interface.ti.com">interface.ti.com</a>	Energy	<a href="http://www.ti.com/energy">www.ti.com/energy</a>
Logic	<a href="http://logic.ti.com">logic.ti.com</a>	Industrial	<a href="http://www.ti.com/industrial">www.ti.com/industrial</a>
Power Mgmt	<a href="http://power.ti.com">power.ti.com</a>	Medical	<a href="http://www.ti.com/medical">www.ti.com/medical</a>
Microcontrollers	<a href="http://microcontroller.ti.com">microcontroller.ti.com</a>	Security	<a href="http://www.ti.com/security">www.ti.com/security</a>
RFID	<a href="http://www.ti-rfid.com">www.ti-rfid.com</a>	Space, Avionics & Defense	<a href="http://www.ti.com/space-avionics-defense">www.ti.com/space-avionics-defense</a>
RF/IF and ZigBee® Solutions	<a href="http://www.ti.com/lprf">www.ti.com/lprf</a>	Video and Imaging	<a href="http://www.ti.com/video">www.ti.com/video</a>
		Wireless	<a href="http://www.ti.com/wireless-apps">www.ti.com/wireless-apps</a>