

features

- Radial Format
- 40°C to 85°C Operating Temp
- Up to 13A I_{DC}
- 10μH to 47μH
- Low DC Resistance
- Fully Tinned Leads
- PCB Mounting Hole
- Low Temperature Dependence
- MIL-I-23053/5 Class III Sleeving
- Supplied in Packs of 50
- Custom Parts Available

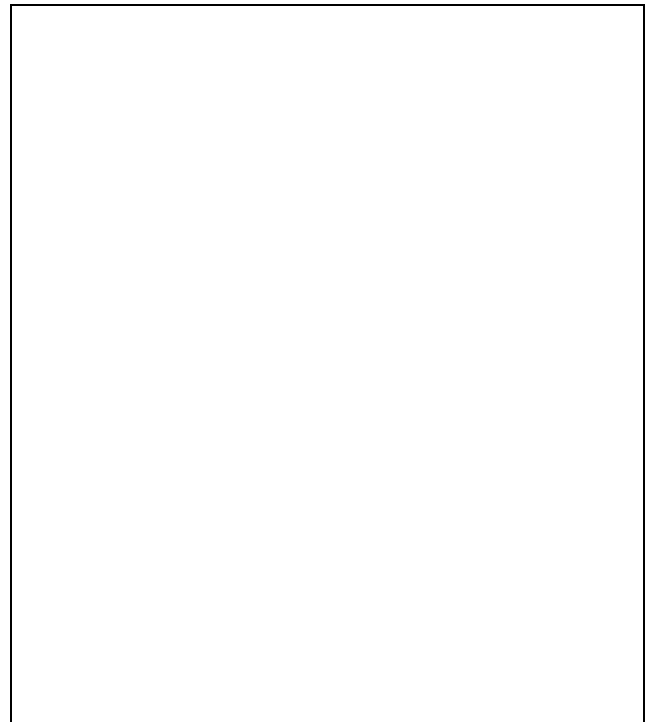

description

The 1400 Series is suitable for many power supply and other general purpose filtering applications. The use of a non-magnetic screw will ensure mechanical stability.

schematic

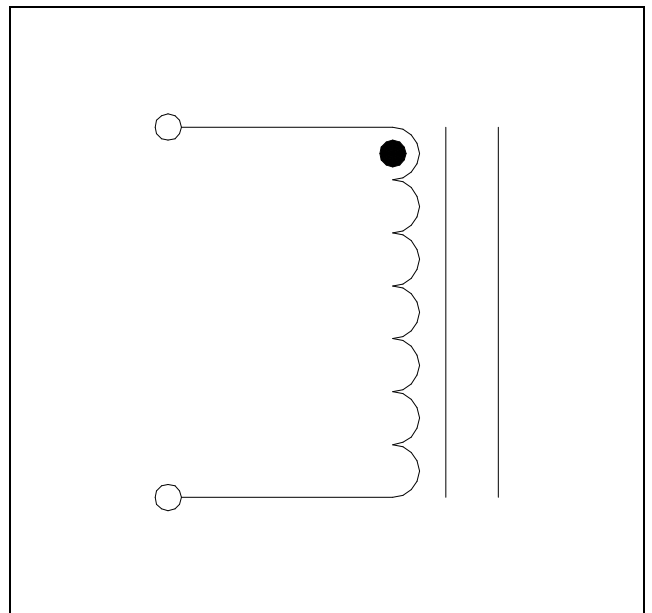

1400 SERIES

absolute maximum ratings over operating free air temperature range

Operating free air temperature range	-40°C to 85°C
Storage temperature range	-55°C to 125°C

1400 SERIES

Bobbin Type Inductors

electrical characteristics over operating free air temperature range

Part Number	Inductance ($\pm 10\%$) (at 1kHz) μH	R_{DC} (max.) Ω	I_{DC} cont. A	Temp rise (at I_{DC}) $^{\circ}\text{C}$	Nominal Q at f kHz		Nominal Self Resonant Frequency MHz
					Q	f	
14 103 13	10	0.007	13	20	54	50	20.7
14 153 12	15	0.009	12	25	42	50	12.7
14 223 11	22	0.011	11	27	64	100	9.3
14 333 93	33	0.015	9.3	25	27	50	9.1
14 473 83	47	0.019	8.3	25	40	100	6.0
14 473 85	47	0.021	8.5	26	33	100	6.7
14 683 62	68	0.032	6.2	27	32	100	5.3
14 683 73	68	0.022	7.3	27	45	100	5.3
14 104 54	100	0.042	5.4	27	24	100	4.6
14 104 60	100	0.033	6.0	29	37	100	3.9
14 104 78	100	0.040	7.8	28	34	50	3.3
14 154 40	150	0.069	4.0	26	24	50	3.4
14 154 49	150	0.051	4.9	27	34	50	2.9
14 154 65	150	0.042	6.5	29	46	100	2.4
14 154 73	150	0.036	7.3	29	42	50	3.2
14 224 35	220	0.096	3.5	29	22	50	2.8
14 224 41	220	0.073	4.1	25	33	100	2.3
14 224 55	220	0.062	5.5	27	30	50	2.2
14 224 63	220	0.050	6.3	27	47	100	1.8
14 304 30	300	0.140	3.0	23	26	50	2.6
14 304 33	300	0.100	3.5	25	37	50	2.2
14 304 50	300	0.080	5.0	29	28	50	1.7
14 304 70	300	0.054	7.0	28	43	50	1.4

outline dimensions (All dimensions in mm)

Part Number	Outline Dimensions					Footprint	
	a	b	c	d	Øe	f	Øg
14 103 13	27.0	24.4	14.0	1.30	4.5*	23.9	2.6
14 153 12	27.0	24.4	14.0	1.30	4.5*	23.9	2.6
14 223 11	27.0	24.4	14.0	1.30	4.5*	23.9	2.6
14 333 93	27.0	24.4	14.0	1.30	4.5*	23.9	2.6
14 473 83	27.0	24.4	18.5	1.30	4.5*	23.9	2.6
14 473 85	26.8	24.4	14.0	1.20	4.5*	23.8	2.4
14 683 62	26.5	24.4	14.0	1.08	4.5*	23.7	2.1
14 683 73	27.0	24.4	18.5	1.30	4.5*	23.9	2.6
14 104 54	26.4	24.4	14.0	1.02	4.5*	23.6	2.0
14 104 60	26.8	24.4	18.5	1.20	4.5*	23.8	2.4
14 104 78	32.4	29.8	21.8	1.30	5.1	29.3	2.6
14 154 40	26.2	24.4	14.0	0.90	4.5*	23.5	1.8
14 154 49	26.4	24.4	18.5	1.02	4.5*	23.6	2.0
14 154 65	32.2	29.8	21.8	1.20	5.1	29.2	2.4
14 154 73	32.4	29.8	26.5	1.30	5.1	29.3	2.6
14 224 35	26.1	24.4	14.0	0.85	4.5*	23.5	1.7
14 224 41	26.3	24.4	18.5	0.97	4.5*	23.6	1.9
14 224 55	32.1	29.8	21.8	1.14	5.1	29.1	2.2
14 224 63	32.4	29.8	26.5	1.30	5.1	29.3	2.6
14 304 30	25.9	24.4	14.0	0.75	4.5*	23.4	1.5
14 304 33	26.2	24.4	18.5	0.90	4.5*	23.5	1.8
14 304 50	31.8	29.8	21.8	1.02	5.1	29.0	2.0
14 304 70	39.4	36.8	27.1	1.30	6.3	36.3	2.6

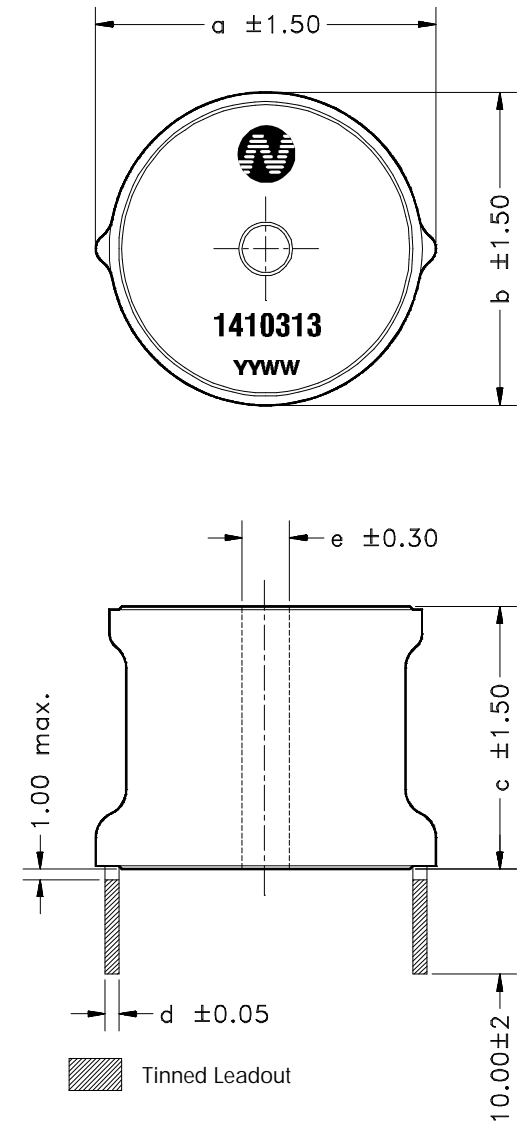

recommended footprint details

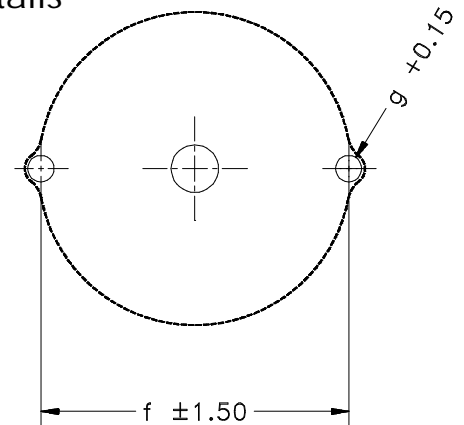

* The drilled hole for these devices have a $6.10\text{Ø} \times 2.40$ countersink.

1400 SERIES

Bobbin Type Inductors

electrical characteristics over operating free air temperature range

Part Number	Inductance (±10%) (at 1kHz) μH	R _{DC} (max.) Ω	I _{DC} cont. A	Temp rise (at IDC) °C	Nominal Q at f kHz		Nominal Self Resonant Frequency MHz
					Q	f	
14 334 28	330	0.150	2.8	24	22	50	2.5
14 334 33	330	0.107	3.3	25	29	50	2.0
14 334 45	330	0.091	4.5	29	25	50	1.6
14 334 51	330	0.068	5.1	29	45	50	1.4
14 334 63	330	0.050	6.3	29	45	50	1.2
14 474 23	470	0.222	2.3	28	34	50	2.0
14 474 27	470	0.149	2.7	24	25	50	1.6
14 474 40	470	0.125	4.0	29	24	50	1.4
14 474 48	470	0.094	4.8	27	60	50	1.2
14 474 59	470	0.075	5.9	29	60	50	1.0
14 684 20	680	0.276	2.0	25	23	50	1.6
14 684 22	680	0.226	2.2	28	28	50	1.3
14 684 31	680	0.173	3.1	27	60	10	1.0
14 684 40	680	0.128	4.0	27	42	50	1.1
14 684 47	680	0.101	4.7	29	43	50	0.9
14 105 16	1.0mH	0.419	1.6	24	30	50	1.4
14 105 17	1.0mH	0.350	1.7	26	35	50	1.2
14 105 24	1.0mH	0.277	2.4	28	33	50	1.0
14 105 31	1.0mH	0.194	3.1	29	49	50	0.9
14 105 40	1.0mH	0.180	4.0	30	49	10	0.8
14 155 13	1.5mH	0.630	1.3	27	34	50	1.0
14 155 14	1.5mH	0.518	1.4	26	47	50	0.8
14 155 17	1.5mH	0.374	1.7	26	28	50	0.7

outline dimensions (All dimensions in mm)

Part Number	Outline Dimensions					Footprint	
	a	b	c	d	Øe	f	Øg
14 334 28	25.9	24.4	14.0	0.76	4.5*	23.4	1.5
14 334 33	26.2	24.4	18.5	0.90	4.5*	23.5	1.8
14 334 45	31.8	29.8	21.8	1.02	5.1	29.0	2.0
14 334 51	32.2	29.8	26.5	1.20	5.1	29.2	2.4
14 334 63	39.4	36.8	27.1	1.30	6.3	36.3	2.6
14 474 23	25.7	24.4	14.0	0.67	4.5*	23.3	1.3
14 474 27	26.1	24.4	18.5	0.85	4.5*	23.5	1.7
14 474 40	31.7	29.8	21.8	0.97	5.1	29.0	1.9
14 474 48	31.9	29.8	26.5	1.08	5.1	29.1	2.1
14 474 59	39.4	36.8	27.1	1.30	6.3	36.3	2.6
14 684 20	25.7	24.4	14.0	0.67	4.5*	23.3	1.3
14 684 22	25.9	24.4	18.5	0.75	4.5*	23.4	1.5
14 684 31	31.6	29.8	21.8	0.90	5.1	28.9	1.8
14 684 40	31.8	29.8	26.5	1.02	5.1	29.0	2.0
14 684 47	39.2	36.8	27.1	1.20	6.3	36.2	2.4
14 105 16	25.6	24.4	14.0	0.60	4.5*	23.2	1.2
14 105 17	25.7	24.4	18.5	0.67	4.5*	23.3	1.3
14 105 24	31.4	29.8	21.8	0.79	5.1	28.8	1.5
14 105 31	31.6	29.8	26.5	0.92	5.1	28.9	1.8
14 105 40	38.8	36.8	27.1	1.02	6.3	36.0	2.0
14 155 13	25.5	24.4	14.0	0.54	4.5*	23.1	1.0
14 155 14	25.6	24.4	18.5	0.60	4.5*	23.2	1.2
14 155 17	31.3	29.8	21.8	0.75	5.1	28.8	1.5

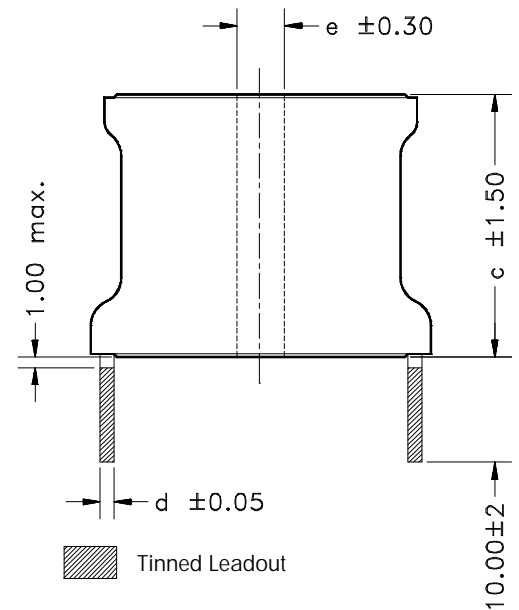
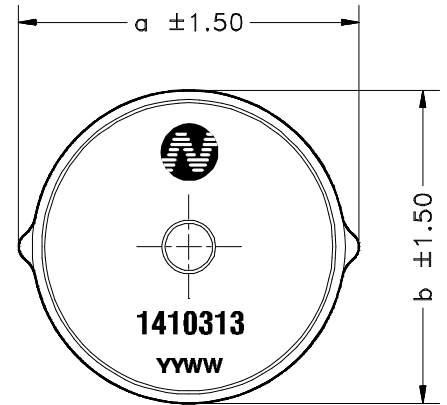

recommended footprint details

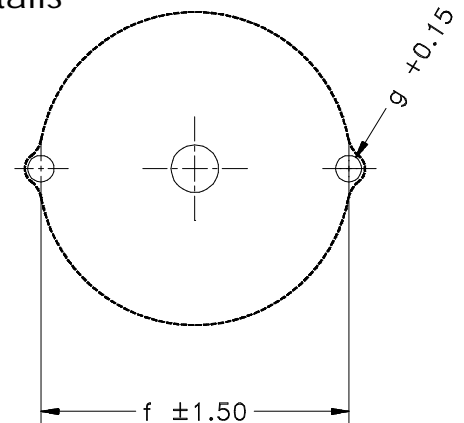

* The drilled hole for these devices have a 6.10Ø x 2.40 countersink.

1400 SERIES

Bobbin Type Inductors

electrical characteristics over operating free air temperature range

Part Number	Inductance ($\pm 10\%$) (at 1kHz) mH	R _{DC} (max.) Ω	I _{DC} cont. A	Temp rise (at IDC) $^{\circ}\text{C}$	Nominal Q at f kHz		Nominal Self Resonant Frequency MHz
					Q	f	
14 155 25	1.5	0.304	2.5	28	32	50	0.7
14 155 33	1.5	0.240	3.3	30	22	50	0.7
14 225 09	2.2	0.916	0.9	25	43	50	0.9
14 225 12	2.2	0.649	1.2	25	33	50	0.7
14 225 14	2.2	0.622	1.4	27	33	50	0.6
14 225 20	2.2	0.486	2.0	29	21	100	0.6
14 225 27	2.2	0.317	2.7	28	21	100	0.6
14 335 07	3.3	1.428	0.70	22	45	50	0.8
14 335 10	3.3	0.992	1.0	26	20	50	0.7
14 335 12	3.3	0.861	1.2	26	20	50	0.5
14 335 16	3.3	0.712	1.6	28	38	50	0.4
14 335 21	3.3	0.550	2.1	29	22	50	0.4
14 475 06	4.7	2.200	0.6	27	60	50	0.6
14 475 08	4.7	1.436	0.8	26	65	50	0.5
14 475 09	4.7	1.250	0.9	28	57	10	0.5
14 475 12	4.7	1.038	1.2	28	50	10	0.4
14 475 18	4.7	0.750	1.8	29	54	10	0.3
14 685 05	6.8	2.810	0.5	24	50	50	0.5
14 685 07	6.8	2.214	0.7	25	47	50	0.4
14 685 08	6.8	1.884	0.8	26	30	50	0.4
14 685 12	6.8	1.278	1.2	28	20	50	0.3
14 685 14	6.8	0.943	1.4	26	17	50	0.3
14 905 10	9.0	1.950	1.0	28	33	50	0.2

1400 SERIES

Bobbin Type Inductors

outline dimensions (All dimensions in mm)

Part Number	Outline Dimensions					Footprint	
	a	b	c	d	Øe	f	Øg
14 155 25	31.5	29.8	26.5	0.85	5.1	28.9	1.7
14 155 33	38.8	36.8	27.1	1.02	6.3	36.0	2.0
14 225 09	25.3	24.4	14.0	0.48	4.5*	23.1	0.9
14 225 12	25.6	24.4	18.5	0.60	4.5*	23.2	1.2
14 225 14	31.1	29.8	21.8	0.67	5.1	28.7	1.3
14 225 20	31.4	29.8	26.5	0.79	5.1	28.8	1.5
14 225 27	38.6	36.8	27.1	0.92	6.3	35.9	1.8
14 335 07	25.2	24.4	14.0	0.43	4.5*	23.0	0.8
14335 10	25.5	24.4	18.5	0.54	4.5*	23.1	1.0
14 335 12	31.0	29.8	21.8	0.60	5.1	28.6	1.2
14 335 16	31.1	29.8	26.5	0.67	5.1	28.7	1.3
14 335 21	38.5	36.8	27.1	0.85	6.3	35.9	1.7
14 475 06	25.2	24.4	14.0	0.39	4.5*	23.0	0.7
14 475 08	25.3	24.4	18.5	0.48	4.5*	23.1	0.9
14 475 09	30.9	29.8	21.8	0.54	5.1	28.5	1.0
14 475 12	31.0	29.8	26.5	0.60	5.1	28.6	1.2
14 475 18	38.3	36.8	27.1	0.75	6.3	35.8	1.5
14 685 05	25.2	24.4	14.0	0.39	4.5*	23.0	0.7
14 685 07	25.2	24.4	18.5	0.43	4.5*	23.0	0.8
14 685 08	30.7	29.8	21.8	0.48	5.1	28.5	0.9
14 685 12	31.0	29.8	26.5	0.60	5.1	28.6	1.2
14 685 14	38.3	36.8	27.1	0.75	6.3	35.8	1.5
14 905 10	30.9	29.8	26.5	0.54	5.1	28.5	1.0

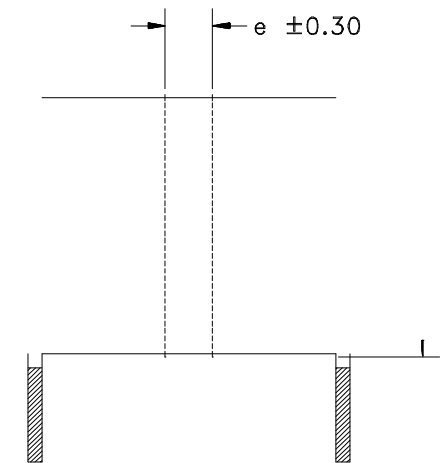
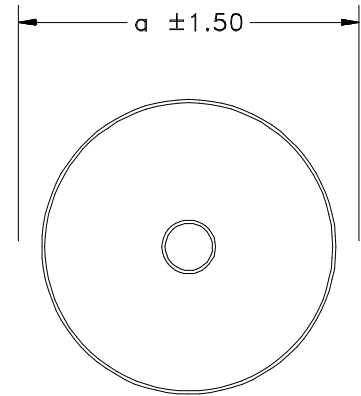

Tinned Leadout

recommended footprint details

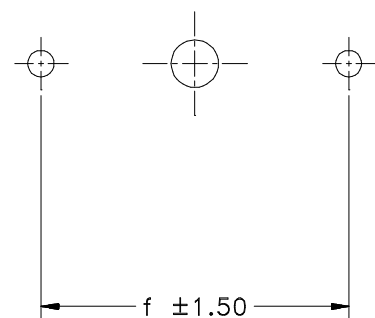

* The drilled hole for these devices have a 6.10Ø x 2.40 countersink.

1400 SERIES

Bobbin Type Inductors

electrical characteristics over operating free air temperature range

Part Number	Inductance ($\pm 10\%$) (at 1kHz) mH	R _{DC} (max.) Ω	I _{DC} cont. A	Temp rise (at IDC) $^{\circ}\text{C}$	Nominal Q at f kHz		Nominal Self Resonant Frequency MHz
					Q	f	
14 106 04	10	4.340	0.4	22	51	50	0.4
14 106 05	10	3.394	0.5	24	48	50	0.3
14106 06	10	2.294	0.6	25	48	50	0.2
14 106 10	10	1.950	1.0	28	35	50	0.2
14 106 11	10	1.394	1.1	27	30	50	0.1
14 156 04	15	4.912	0.4	25	61	10	0.2
14 156 05	15	3.740	0.5	21	55	10	0.2
14 156 07	15	2.960	0.7	27	50	10	0.1
14 156 10	15	2.186	1.0	29	55	10	0.1
14 226 04	22	6.926	0.4	26	30	50	0.2
14 226 06	22	5.000	0.6	29	25	50	0.1
14 226 08	22	3.500	0.8	29	21	50	0.1
14 336 04	33	7.306	0.4	21	30	50	0.1
14 336 06	33	4.838	0.6	24	25	50	0.1
14 476 05	47	7.446	0.5	25	30	10	0.1

Note : All data taken at T_A=25°C.

outline dimensions (All dimensions in mm)

Part Number	Outline Dimensions					Footprint	
	a	b	c	d	Øe	f	Øg
14 106 04	25.1	24.4	14.0	0.34	4.5*	22.9	0.6
14 106 05	25.2	24.4	18.5	0.39	4.5*	23.0	0.7
14 106 06	30.9	29.8	21.8	0.54	5.1	28.5	1.0
14 106 10	30.9	29.8	26.5	0.54	5.1	28.5	1.0
14 106 11	38.1	36.8	27.1	0.67	6.3	35.7	1.3
14 156 04	25.1	24.4	18.5	0.34	4.5*	22.9	0.6
14 156 05	30.6	29.8	21.8	0.43	5.1	28.4	0.8
14 156 07	30.7	29.8	26.5	0.48	5.1	28.5	0.8
14 156 10	38.0	36.8	27.1	0.60	6.3	35.6	1.2
14 226 04	30.5	29.8	21.8	0.34	5.1	28.3	0.6
14 226 06	30.6	29.8	26.5	0.43	5.1	28.4	0.8
14 226 08	37.9	36.8	27.1	0.54	6.3	35.5	1.0
14 336 04	30.6	29.8	26.5	0.39	5.1	28.4	0.7
14 336 06	37.7	36.8	27.1	0.48	6.3	35.5	0.9
14 476 05	37.6	36.8	27.1	0.43	6.3	35.4	0.8

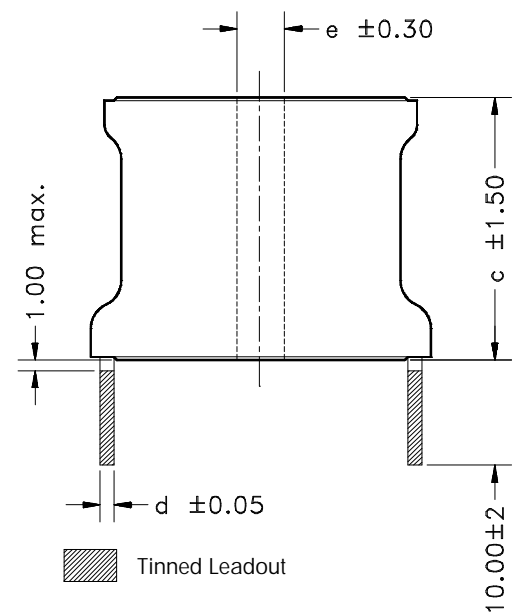
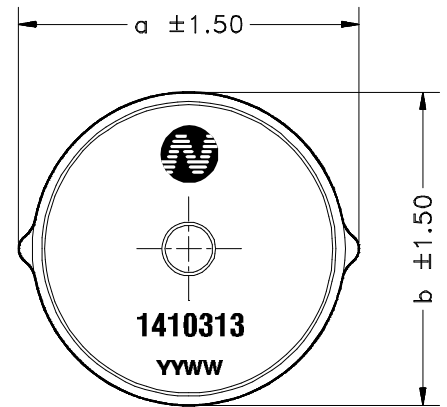

* The drilled hole for these devices have a $6.10\text{Ø} \times 2.40$ countersink

recommended footprint details

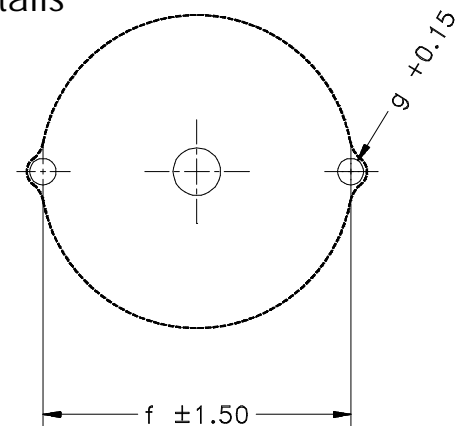

1400 SERIES

Bobbin Type Inductors

typical core characteristics

Inductance Temperature Coefficient	Resistance Temperature Coefficient	Curie Temperature T _c	Saturation Flux BSAT
215ppm	4100ppm	130°C	240mT

ordering information

The part number consists of seven digits 14 XXX YY. Where XXX is the inductance in nH expressed as 2 digits + exponent, YY is the current rating in multiples of 0.1A, up to 9.9A. If the current rating exceeds 9.9A YY=current rating in Amps.