

459-951 | 459-939
+

ITW Electronic Packaging

1 of 3

CONTROLS FOR ANTISTATIC TUBE

The standard used by ITW for testing antistatic tubes is the American National Standard ANSI/EIA-541-1988. Packaging material standards for ESD sensitive items.

CONDITION CONTROLS

The machine used is an ETS 405 D Static Decay Meter
Humidity control chamber

- The tubes are conditioned for 48 hours in a control chamber at 12% RH, which is more stringent than EIA-541 requirements of 15% RH.
 - A static decay test on the tube is carried out by putting a surface charge of 5000 volts on the tube which should dissipate in less than 2s. ITW product averages 0.5 s. decay time.
- The same test is made 3 times on the positive side and negative. The results are within 0.02 seconds to pass the test.
- Decay results of each daily production are recorded and are available on request.

RESISTIVITY CONTROL

The machine is an ETS 806
Surface resistivity meter

- The technical specification for anti-static tubes is $>1*10e6$ and $<1*10e12$
- ITW average products $1*10e9$

ANTISTATIC SOLUTION CONTROL

- The antistatic solution is tested once a day for conductivity and alcohol content.

PRODUCTION CONTROL

- Hourly inspection
- Samples of each batch are kept on the shelf for 6 months.

PRINT ANTISTATIC IN BLUE

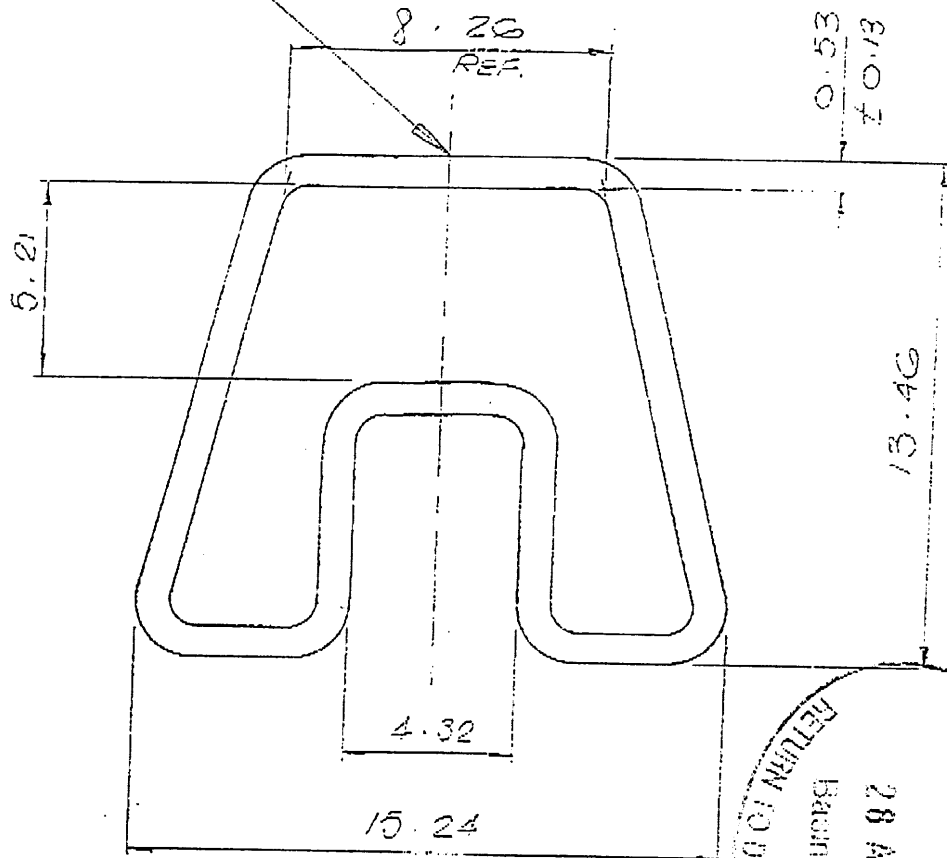

IF THIS STAMP IS
MAY BE IN COLOUR
THEN THIS IS AN
ORIGINAL COPY

RETURN TO DESIGN
Basingstoke
28 AUG 1989
NOT A COPY

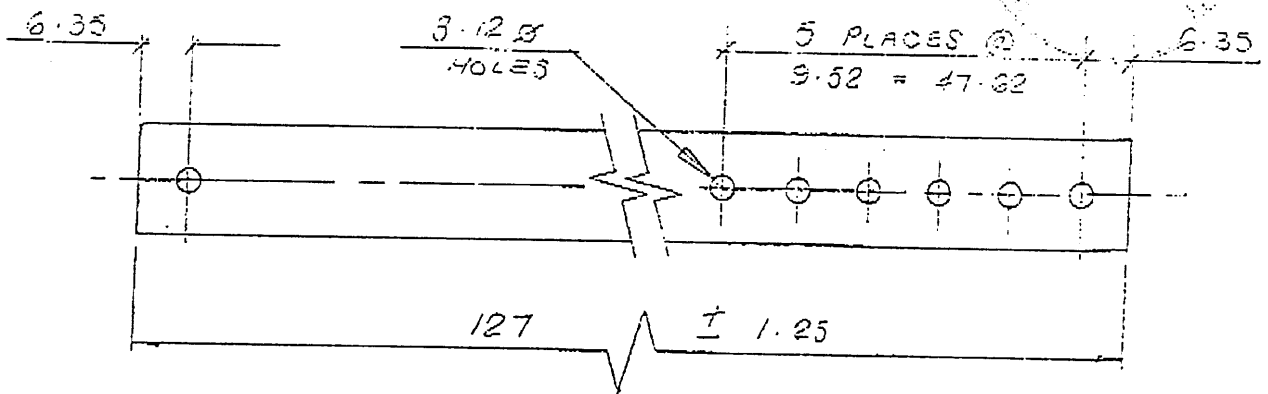

ALL UNSPECIFIED TOLERANCES ANGLES $\pm 1^\circ$ 0.0 \pm 0.50 0.00 \pm 0.25 0.000 \pm 0.10

REVISIONS

Issue No. / Colour

EXTRUDED PRODUCTS
A DIVISION OF ITW LIMITED
WEST HANI INDUSTRIAL ESTATE/GRAFTON WAY
BASINGSTOKE/HANTS/RO22 8JY/
TEL: (0256) 496772 FAX: 465084
TELEFAX: (0256) 464777

Date 21.9.89

P.R. No. 8804	Des. TX	Drn. Vc	Date 21.9.89	Chk.	Area	Wt.	Matl. CL. PVC.	NAME 300 DIP
SCALE 5:1 1:1	ALL DIMS IN mms.		TOOL REF.		PART No. 4		28 40805 23	

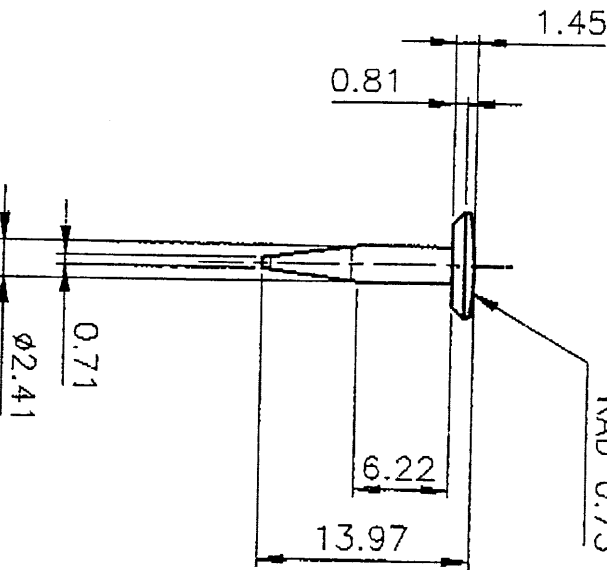
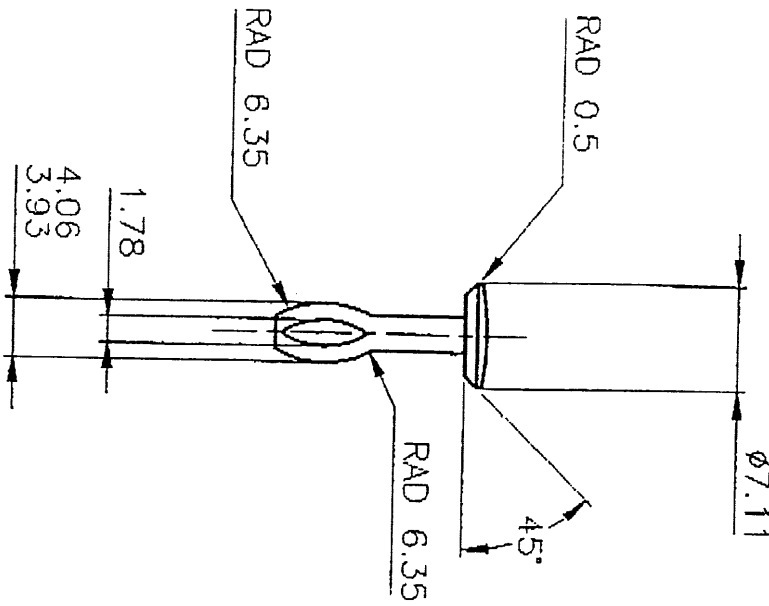

CUSTOMER DETAILS		
CUSTOMER		
CUSTOMER PART No.		
CUSTOMER APPROVAL		
APPROVAL DATE		
REVISIONS		
ISSUE	DATE	MOD. No.
1	26-10-94	
	DRAWING RAISED	ISSUE

IF THIS STAMP IS NOT RED IN COLOUR THEN THIS IS AN UNCONTROLLED COPY

Electronic Packaging
 GRAFTON WAY, WEST HAM INDUSTRIAL ESTATE,
 BASINGSTOKE, HAMPSHIRE, RG22 6HY
 TEL: (0256) 466772 FAX: (0256) 461900

P.R. No.	N/A	DRAWN	MCP/other
COLOUR	BLACK	DATE	26-10-94
MATERIAL	NYLON	CHECKED	
WEIGHT		DATE	

ALL UNSPECIFIED TOLERANCES:
 ALL DIMENSIONS IN mm

0.0	- +0.50
0.00	- +0.25
0.000	- +0.10
ANGLES	- *1°

TITLE : THUMB TAK