

SIEMENS



LOGO! Now twice as ingenious!

The choice is yours:
the well-proven logic module – now also with Ethernet

Micro Automation

siemens.com/logo

In infrastructure ...



Heating/ventilation/air-conditioning

- Energy management
- Heating
- Cooling systems
- Ventilation systems
- Air-conditioning systems

Building management systems

- Light control (outdoor and indoor lighting)
- Door/gate control
- Roller blind and awning control
- Irrigation and sprinkler systems

Monitoring equipment

- Access controls
- Monitoring of drive controls
- Alarm systems
- Limit value checks
- Traffic light controllers
- Luggage inspection

Profitable switching and controlling

In automation, all of the potential means of savings must be consistently used – from planning and commissioning to operation. What is needed are systems that allow the constantly increasing requirements to be quickly and economically fulfilled: Intelligent solutions that stand out due to maximum flexibility, reliability, and user-friendliness. The best example of innovative technology that completely fulfills these high requirements is LOGO! – the world's leading logic module for switching and controlling.

Intelligent technology with a vision

LOGO! is ideally suited for implementing simple automation tasks in industry and building management systems. The intelligent logic module is characterized by maximum user-friendliness and it leaves little to be desired in terms of functionality, thanks in no small part to the high memory capacity and efficient use of memory. With the use of expansion modules, LOGO! can control even the most complex plants without any problems.

Maximum flexibility due to consistent modularity

A wide range of modules make it possible to individually expand LOGO! to 24 digital inputs, 16 digital outputs, 8 analog inputs, and two analog outputs. Communication modules for AS-Interface and KNX are also available. With the analog output module, for example, you can solve simple control tasks. This is supported by the special functions of PI controller, ramp function, and analog multiplexing.

...and industry



Transport equipment

- Conveyor belts
- Lifting platforms
- Lifts
- Silo systems
- Automatic feeders

Special solutions

- Solar plants
- Use on ships
- Use in extreme ambient conditions
- Display panels and traffic signboards

Machine controls

- Motors, pump and valve controls
- Air compressors
- Extraction and filtering installations
- Sewage plants
- Sawing and planing machines
- Etching and cleaning equipment

Tried and tested millions of times – in numerous applications

In combination with the LOGO! software Soft Comfort, the handling of our logic module is child's play: Creating programs, project simulating and documentation are quite easy using drag & drop – for maximum user-friendliness. In addition, a display with the capability of directly changing process parameters in the message text always ensures professional handling and satisfied users. All of this is the reason why LOGO! has proven itself over the past 15 years in millions of machine and building applications around the world.

New applications made possible by new OBA7 basic units

The performance of LOGO! can be expanded in terms of the number of I/Os and program capacity by means of simple networking. It is not always necessary to switch to more complex PLC configurations for simple networking requirements. Instead, you can remain in the familiar, simple configuration world of our logic module and continue networking easily and cost-effectively. Even in a single family home, there are so many possible applications that the number of I/Os is exceeded by a single LOGO!. The simple networking via Ethernet is useful here. The new communication options via Ethernet now allow small LOGO! networks to be set up – as well as communication with higher-level systems.

Whether in infrastructure
or industry – a quick and
cost-effective solution



Easy expansion
by means
of a text
display or
expansion
modules
for a reliable
solution

LOGO! – simple, brilliant, reliable



LOGO! in assemblies with
the function modules



The simplest connection

LOGO! OBA6 basic units, together with the expansion modules and the external text display, provide a broad and proven basis for reliable solutions in mechanical engineering and building management systems. Practice-oriented function blocks are easily connected via the software using the cursor and their interaction can be immediately tested.



Outstanding performance and overview

With LOGO! four of the eight digital inputs that are available on the hardware can be used as analog inputs and four as high-speed counter inputs up to a frequency of 5 kHz. With a program memory for 200 function blocks, the 12/24 V DC devices provide sufficient capacity for many stand-alone applications. Up to 50 four-line message texts with a maximum of 32 characters per line ensure user-friendliness in practice and clearly display all of the relevant machine parameters. Well-conceived options such as ticker text, bar graph or status parameter also contribute to the user-friendliness. Function blocks for arithmetic and pulse width modulation open up further usage options. Last but not least: the Teleservice option, which often does away with costly on-site service calls and really pays off if you sell your systems cross-regionally.

Additional text display

LOGO! allows an additional text display, which is perfectly tailored to the needs of a logic module, to be connected. It is directly connected to the LOGO! without a communication module. The configuration is done using the same function block as for the internal display. You decide whether message texts are displayed on the internal or external display – or on both.

Highlights of LOGO!

- Can be modularly expanded up to 50 I/Os
- 230 V units can be expanded with analog modules
- All three phases can be combined in a configuration
- Extremely simple software
- Display of up to 50 messages, either by LC display on the module, external TD, or both together
- Supports 12 or 16 standard characters per line, depending on the selected character set; you can double the number of characters with the ticker function
- Users can toggle between 2 languages
- Display of up to 4 bar charts and up to 4 I/O status parameters per message
- Controllable backlight of both displays can also be used in continuous operation
- Password protection for STOP mode on TD



LOGO! – and now also with Ethernet

LOGO! 0BA7 impressively proves that we are constantly further developing our pioneering logic module. The two new basic devices supplement the existing 0BA6 basic devices, which have already been tried and tested worldwide.

Proven devices have been consistently further developed

The developmental leap forward can even be seen on the outside of our new LOGO! 0BA7 basic devices: They are wider by two modular widths and the previous interface has been replaced by an Ethernet interface on the underside of the device.

In addition, there is a slot for SD cards on the right front of the device. In spite of these exterior changes, the new devices are compatible with all existing I/O modules. Even programs from the previous LOGO! generations can be used in the new devices.

The highlight of the 0BA7 basic devices is without a doubt the standard Ethernet interface. It is used as a programming interface and for communicating with other LOGO! 0BA7 basic devices or SIMATIC automation components such as SIMATIC S7 CPUs, HMI Panels, and PCs. Up to nine LOGO! devices can be networked via the Ethernet interface.

Standard Ethernet interface for communication with further LOGO! basic units or other automation components



New communication options

The networking is mainly used for direct communication between several LOGO! devices. The advantages that result from this:

- Increasing the number of I/Os in a configuration. One logic module executes the program and the others only serve as an I/O expansion – without processing their own program. This means that a multi-cell layout in the control cabinet is now also possible.
- Expansion of the program memory. All logic modules process their own program and only exchange some of the data among each other.

Function extensions

- Program memory extended to 400 function blocks
- Astronomical clock
- Min./Max.
- Average value
- Analog filter
- Stopwatch
- Macro and library function
- Data logging

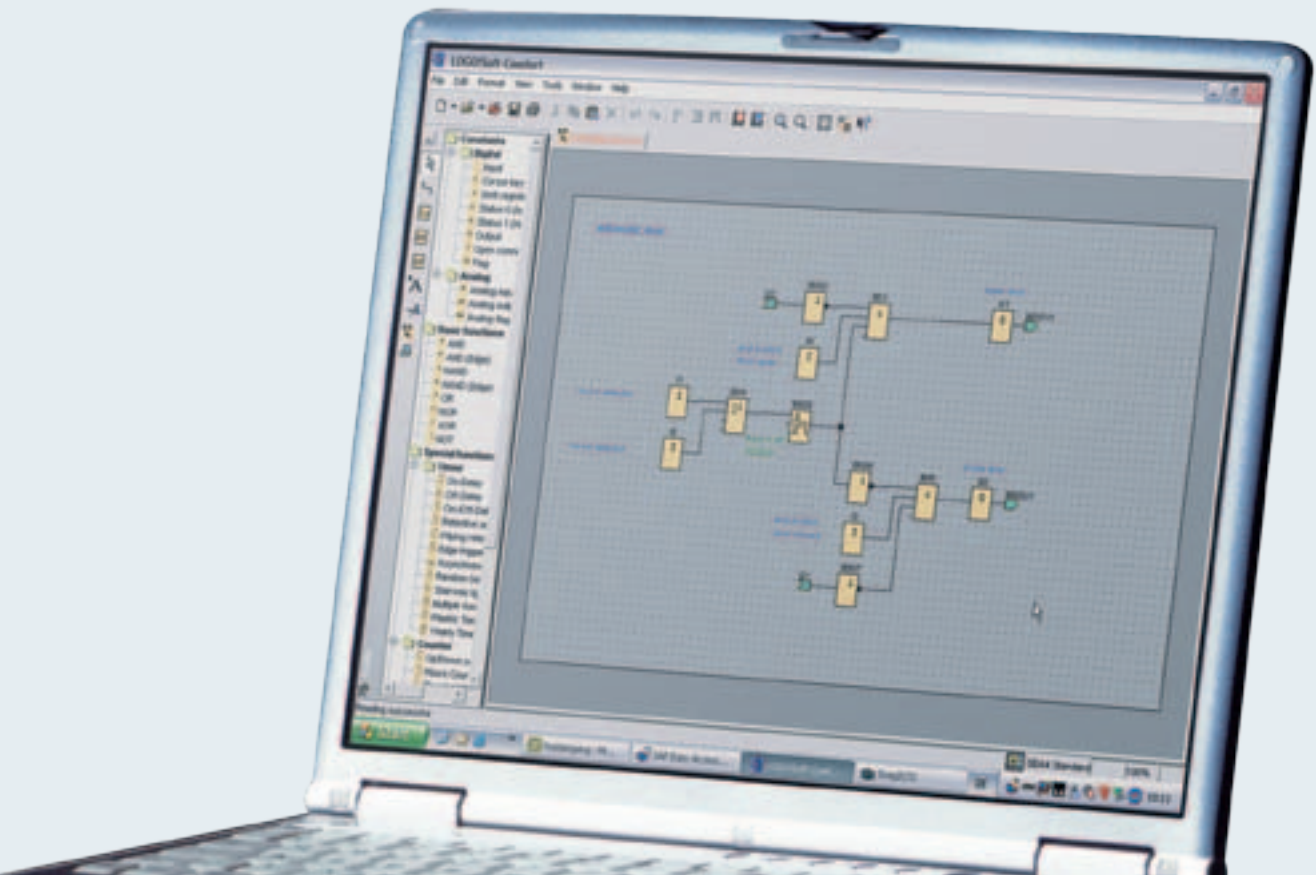

LOGO! Software – simply professional

LOGO! Soft Comfort – stands for sensationally easy and quick configuration. This allows the creation of ladder and function block diagrams by selecting the respective functions and their connection via drag & drop. In addition, the entire switching program can be simulated and tested offline on the PC. Also possible: an online test in both program displays during operation. Last but not least, LOGO! Soft Comfort provides professional documentation with all of the necessary project information such as switching programs, comments, and parameter settings.

A decisive argument for LOGO!

LOGO! Soft Comfort is appealing in every respect. The user-friendliness of our software is unequaled on the market. The preferential configuration in the function block diagram is more manageable than in the contact diagram, especially for programs with many special functions. LOGO! Soft Comfort, however, allows programming in both display formats and the execution of online tests – as the only software in the logic module class. Since it can be executed on three operating system platforms, you will benefit from maximum flexibility when choosing a computer and a high-end device is not absolutely essential.

The standard simulation function makes program development easy. You can immediately simulate, optimize and then group individual program sections for total functionality. The outstanding functionality of our software is rounded out by professional tools for creating the user documentation. A context-sensitive help function brings additional advantages: It puts an end to the tiresome business of paging through manuals and reduces the weight of your luggage when making service calls. Last but not least, an integrated tutorial and numerous examples facilitate your entry into modern automation technology.

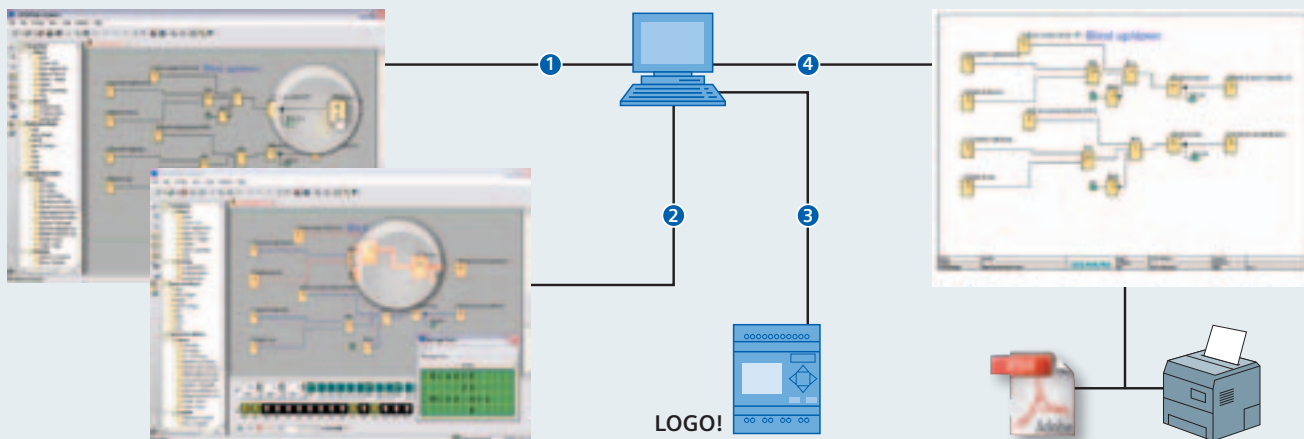

NEW

- Astronomical clock
- Min./Max.
- Average value
- Analog filter
- Stopwatch



More functions ...

With the current version of LOGO! Soft Comfort, you can, of course, easily configure all of the new LOGO! hardware and firmware functions.

The following five function blocks have been added:

- Astronomical clock
- Min./Max.
- Average value
- Analog filter
- Stopwatch

... and important innovations

Creating macro blocks with library function

Recurring parts of programs can be saved separately as complete blocks and used in other programs. You can build up your own block library from regularly used partial applications and quickly and easily integrate them into new projects. This speeds up testing and programming.

Data logging

Data from the production process can be saved in the internal memory of the LOGO! or on a standard SD card in order to either read it with a PC or evaluate it from the SD card at the workstation.

Networking

A real highlight of the LOGO! 0BA7 generation are the different communication modes:

- Communication between LOGO! and LOGO! – the second LOGO! functions as an I/O expansion without its own program.
- Communication between LOGO! and LOGO! – the second LOGO! executes its own program and exchanges some data with the other one.
- Communication between LOGO! and SIMATIC S7 CPUs or Panels, which provide S7 communication via Ethernet.

Sensationally easy and quick programming thanks to 43 function blocks and operating via drag & drop



LOGO! – the proven basic units ...

LOGO! impresses customers due to the wide variety of possible applications and it allows the easy implementation of comprehensive applications – last but not least due to the possibility of selecting from among 38 integrated functions and linking them to up to 200 blocks. When operating and monitoring, the 4-line backlit display with a maximum of 32 characters per line ensures a high degree of user-friendliness. The message text allows the display of text, setpoints and actual values, bar graphs and status parameters. Of course, parameters can be adjusted in the message text. Flexibility is always assured due to the diverse expansion options.



...and the new ones with Ethernet

You have grown with LOGO! and you want to always be able to solve more tasks with a greater demand on industrial communication? Then, the new LOGO! 0BA7 devices are the ideal solution for you. With the new basic devices, you can easily expand old programs by adding functions.

Also possible: the supplementing of additional I/Os or the integration of a user-friendly operator guidance via touch panels. Previously developed LOGO! programs can be used as a basis and the easy configuration continues.

LOGO!
simply ingenious –
and now ...

LOGO! functions

With the eight basic functions and 30 special functions, simple switching programs can be created quickly – either directly on the device or via PC. You can find a large selection of example applications under www.siemens.com/logo

The eight basic functions

	AND (and) series connection NO contact	
	NAND (and not) parallel connection NC contact	
	AND with edge evaluation (pos. edge)	
	NAND (and not) with edge evaluation (neg. edge)	
	OR (or) parallel connection NO contact	
	NOR (or not) series connection NC contact	
	XOR (exclusive or) 2-way changeover	
	NOT (not) inverter*	

LOGO! pays off

Up to 50% cost savings

- Replaces many conventional switching devices
- Requires less space in the control cabinet
- Fewer accessories
- Less storage space
- Saves on servicing costs because it is free of wear

Up to 70% time savings

- Simply snap it onto a standard mounting rail
- Low wiring overhead
- Simple programming using LOGO! Soft Comfort
- Use ready-to-use sample programs at no cost or create and test them on the PC and quickly transfer them free of errors
- Automatic daylight-saving adjustment
- Documentation

Up to 70% space savings

- 4/6 modular widths suffice as a replacement for many relays, time switches, and contactor relays
- 8 basic and 30/35 special functions replace many conventional switching devices

Universally applicable

- Vibration-proof
- High electromagnetic compatibility (EMC)
- Fully industrial-grade
- For all climatic conditions
- Radio suppression class B
- All of the required certifications for worldwide use
- Marine approval

The special functions

ON delay	OFF delay	ON/OFF delay	Latching ON delay	Interval relay/ Pulse output	Interval relay, edge-triggered	Pulse generator

LOGO! basic units 0BA6



LOGO! text display



LOGO! basic units 0BA7



LOGO! basic unit 0BA6



- 38/43 ready-to-use functions integrated – no additional devices such as operating hours counter required
- Linking of 200/400 functions possible
- 8 digital inputs (incl. 4 AI with 12/24 V DC) and 4 digital outputs on board
- Flexibly expandable up to 24 DI, 16 DO, 8 AI, and 2 AO
- Display of message texts, actual and setpoint values and direct modification of the values on the display (not on Pure variants)
- Integrated data retentivity – ensures backup of the current values in the event of a power failure
- Software LOGO! Soft Comfort V 7 for the user-friendly creation of switching programs on the PC for all LOGO! generations, which can run on various operating systems



Random

Staircase lighting timer

Convenience switch

Week time switch

Year time switch

Up/down counter

Operating hours counter

Threshold switch

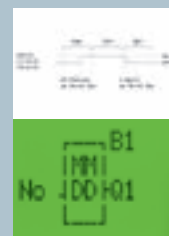
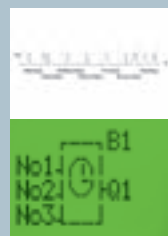
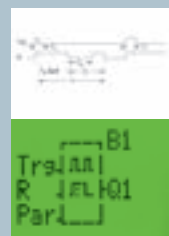
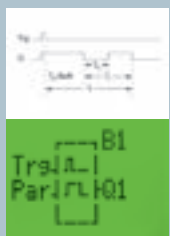
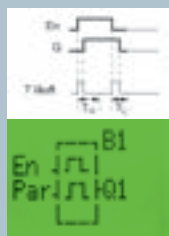



LOGO! basic unit 0BA7

- Standard Ethernet interface as programming interface and for communication with other LOGO! basic devices 0BA7 or SIMATIC automation components such as SIMATIC S7 CPUs, HMI Panels and PCs
- A maximum of 9 LOGO!s can be networked
- Data logging
- Standard SD cards as the storage medium
- Program and connection-compatible with LOGO! 0BA6



LOGO!
simply
twice as
ingenious

Analog comparator

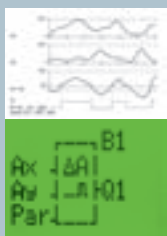

Analog threshold switch

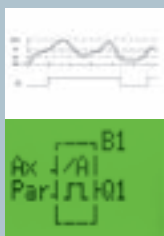

Analog amplifier

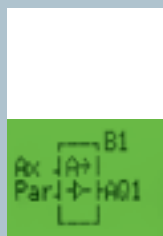

Analog monitoring

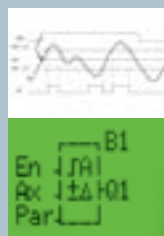

Analog difference threshold switch

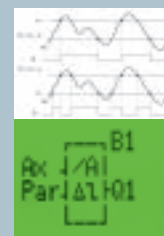

Latching relay



Current impulse relay

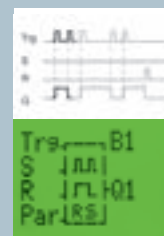

Software switch

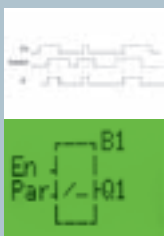

NEW for OBA7

Astronomical clock

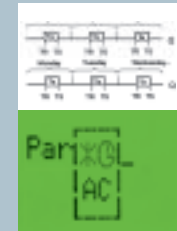

Average value



Analog filter



Stopwatch

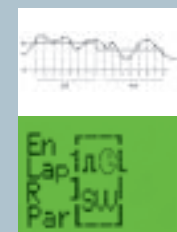

Min./Max.



LOGO! modules

LOGO! text display

For operator prompting and servicing for the display of message texts, input and output statuses, and for setting process parameters (usable as of basic device OBA6, supports the range of functions of the OBA6 basic devices)

- Display of up to 50 messages
- Users can toggle between 2 languages
- Display of up to 4 bar charts and up to 4 I/O status parameters per message
- Supports max. 32 Standard characters per line
- Controllable backlight
- Password protection for RUN/STOP mode on TD

Digital expansion modules*

- Expansion of the digital inputs and outputs:
 - DM8 230R/DM16 230R
 - DM8 24/DM16 24
 - DM8 12/24R
 - DM8 24R
 - DM16 24R

Analog expansion modules*

- Expansion of the analog inputs:
 - AM2 for 0–10 V or 0/4 ... 20 mA signals
 - AM2 RTD for Pt100 or Pt1000 with automatic sensor detection
 - AM2 AQ for 0–10 V or 0/4 ... 20 mA signals

Communication modules*

- CM AS-Interface slave
 - 4 DI/4 DO as interface to the AS-Interface master
- CM EIB/KNX
 - max. 16 DI, 12 DO, 8 AI and 8 AO as interface to the KNX
 - The date and time can be synchronized via KNX
 - All of the digital and analog input and output signals are available as communication objects on the KNX
 - Dimming and shutter/blind actuators on the KNX can be controlled in a system-conformant way

*All expansion modules are available for OBA6 and OBA7.

Shift register

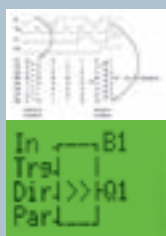

PI controller

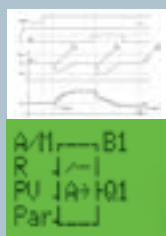

Ramp function



Analog multiplexer

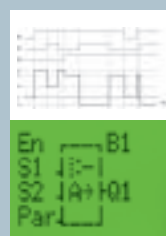

Message text expanded

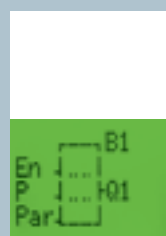

Arithmetic function

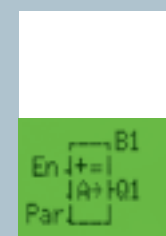

Pulse width modulation

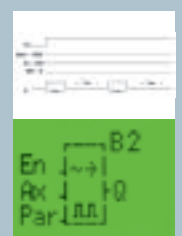



LOGO! 0BA7– more options in detail

With an Ethernet interface and SD card slot, LOGO!

0BA7 opens up completely new perspectives – not only in terms of communication capabilities. The standard SD cards can be used – e.g. to copy programs or save data/projects with comments. In addition, the program memory has been expanded to 400 function blocks and, in place of the optional battery, the internal buffering of the real-time clock has been extended to 20 days.

Communication like never before

Devices with an “E” in their names can communicate with each other via Ethernet. This can happen in various ways:

- **Master/slave connections between LOGO! and LOGO!**

In this case, only one of a maximum of 9 basic devices processes a user program. The others only serve to expand the I/O capacity. They provide the input information of the digital and analog inputs to the first LOGO! and execute the switching commands on the other side for the digital outputs of their hardware, or they forward the analog output values to the I/O. This does away with the limitation on the number of channels of the previous basic devices. Of course, the basic devices that are being used as slaves can be equipped with the proven expansion modules up to the maximum process image.



■ **Master/master connections between LOGO! and LOGO!**

In this mode, up to 9 basic devices can also be connected to each other. However, each LOGO! processes its own program and shares only the generally needed information with the others. In this way, small, networked systems with easy program structures can be created. Each unit can continue to solve its subtask without the others, if necessary.

In both cases, up to 9 basic devices and a PC/PG for programming can be interconnected. The theoretical degree of expansion of a LOGO! configuration is thus 88 DI, 80 DQ, 40 AI, and 18 AQ.

■ **Communication with SIMATIC S7**

The new LOGO! basic modules can be coupled to higher-level automation structures (e.g. SIMATIC S7 CPUs or HMI Panels with Ethernet interface), because they can work with the standard S7 protocol. This allows, for example, the use of SIMATIC Touch Panels for operating a machine controlled by LOGO!. Of course, you can also combine these communication options as needed.

Twice the program memory and five new function blocks

The five new function blocks pay off in practice. Thus, for example, minimum and maximum temperature values can be determined over the course of a day or mean values can be formed over a defined period of time. The duration of any process can be measured using a stopwatch. In addition, there is an astronomical clock, which can be used for such things as controlling outside lighting or feeding times in animal husbandry, and an analog filter, which helps to smooth the influence of interference pulses on the signal profile. Last but not least, the number of usable shift registers has been increased to four. Thus, shift registers with up to 32 bits are now possible.

Completely new perspectives for communication, data handling and storage

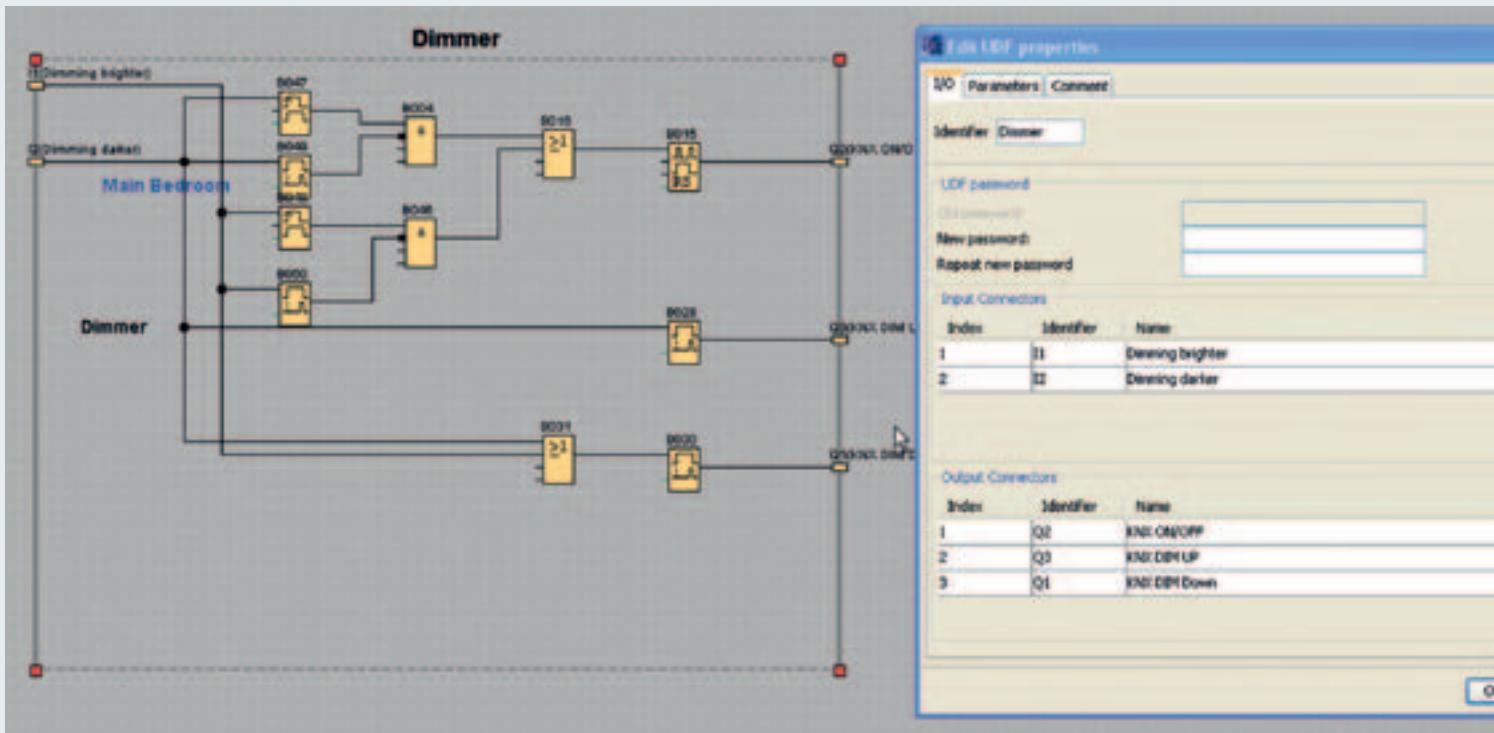

Increased engineering efficiency: reusable sections of a program

More complex applications can be programmed using LOGO! Soft Comfort V7 even easier than before: Macros can now be used and libraries can be created for recurring program sequences (e.g. for roller blind controllers). Corresponding program sections can then be selected and reused at any time. When opening a program that contains macros from the library, you are notified if the macro has been changed since its last use. Macros are also helpful when creating step sequence controls.

New usage options thanks to data logging

Thanks to data logging, you can now save specific production or process data in a data area in the LOGO! – either by using the internal memory or by using a standard SD card up to 8 GB. This is advantageous if LOGO! is used for controlling temperatures or monitoring levels, for example. Corresponding characteristics can be easily documented and evaluated. In the program, the user can define the time intervals in which or the event by which the temperature data or levels are to be recorded.

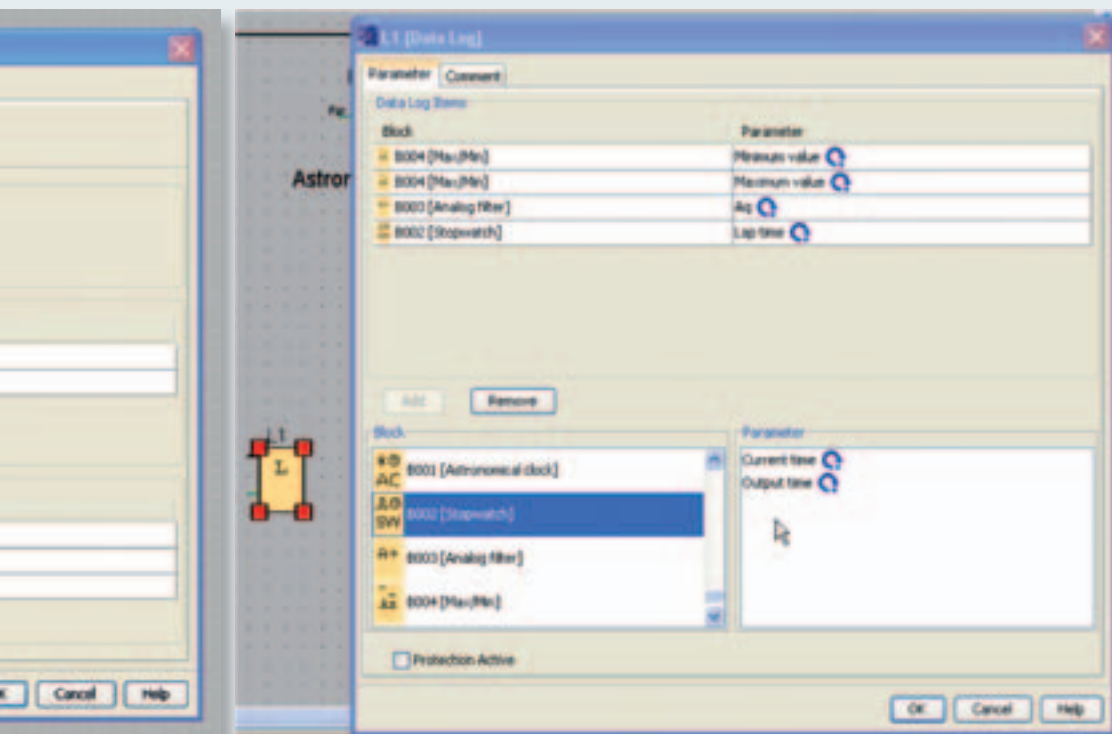

Simply more –
many more
options in
every respect

New advantages, old strengths

The status of the inputs and outputs are transferred to the PC via the Ethernet interface and are documented there in an Excel table, for example. However, the new software also facilitates programming for users of the previous LOGO!: Function blocks can be exchanged without having to create new connections. The simplified handling includes additional capabilities for aligning the blocks and the additional linking of comments.

The new basic devices are fully compatible with the old ones, apart from the increased width of the devices (108 mm instead of 72 mm), which is due to the implemented innovations. They have the built-in display, cursor keys, and the familiar signal ports. Therefore, with their expanded functionality, they can completely replace the old OBA6 basic devices.

In addition, all of the old expansion modules can be used on the new basic devices without restrictions. The only thing that must be noted is that an Ethernet cable is required in order to directly transfer an existing program from one PC to one of the new basic devices.

Of course, the new generation of devices are also characterized by the proven strengths of LOGO!: from the flexible, modular design and easy creation of programs, project simulation and documentation by means of drag & drop to the built-in display with HMI functionality.

LOGO! modular – the technical details

Basic units	LOGO! 12/24RC ¹⁾ , LOGO! 12/24RCo ²⁾	LOGO! 24C, LOGO! 24Co	LOGO! 24RC ¹⁾ , LOGO! 24RCo ²⁾
Inputs	8	8	8
of which can be used in analog mode	4 (0 to 10 V)	4 (0 to 10 V)	–
Input/supply voltage	12/24 V DC	24 V DC	24 V AC/DC
Permissible range with signal "0" with signal "1"	10.8 V ... 28.8 V DC max. 5 V DC min. 8.5 V DC	20.4 V ... 28.8 V DC max. 5 V DC min. 12 V DC	20.4 ... 28.8 V DC 20.4 ... 26.4 V AC max. 5 V AC/DC
Input current	1.5 mA (I3 ... I6), 0.1 mA (I1, I2, I7, I8)	2 mA (I3 ... I6), 0.1 mA (I1, I2, I7, I8)	min. 12 V AC/DC, 2.5 mA
Outputs	4 relays	4 transistors	4 relays
Continuous current	10 A with resistive load; 3 A with inductive load	0.3 A	10 A with resistive load; 3 A with inductive load
Short-circuit protection	External fuse required	Electronic (approx. 1 A)	External fuse required
Switching frequency	2 Hz with resistive load; 0.5 Hz with inductive load	10 Hz	2 Hz with resistive load; 0.5 Hz with inductive load
Cycle time	< 0.1 ms/function	< 0.1 ms/function	< 0.1 ms/function
Integrated time switches/ power reserve	Yes / typ. 80 h (2 years with battery module)	Yes / typ. 80 h (2 years with battery module)	Yes / typ. 80 h (2 years with battery module)
Connection cables	2 x 1.5 mm ² or 1 x 2.5 mm ²		
Ambient temperature	0 to +55 °C		
Storage temperature	–40 °C to +70 °C		
Emitted interference	In accordance with EN 55011 (limit class B)		
Degree of protection	IP20		
Certification	In accordance with VDE 0631, IEC 1131, FM Class 1, Div 2, cULus, C-Tick, marine approvals		
Mounting	On 35 mm standard mounting rail, 4 MW, or wall-mounting		
Dimensions	72 (4 MW) x 90 x 55 mm (W x H x D)		
Programming cable	LOGO! PC cable, (RS232 or USB)	LOGO! PC cable, (RS232 or USB)	LOGO! PC cable, (RS232 or USB)
Optional backup battery	Yes	Yes	Yes
LOGO! <=> LOGO! communication (Ethernet)	No	No	No
LOGO! <=> network (Ethernet)	No	No	No
Maximum program memory	200 blocks	200 blocks	200 blocks
External memory module	LOGO! memory card	LOGO! memory card	LOGO! memory card
Data logging	No	No	No
Online status chart	No	No	No
Macro function	No	No	No

Digital modules	LOGO! DM8 12/24R	LOGO! DM8 24 DM16 24
Inputs	4	4/8
Input/supply voltage	12/24 V DC	24 V DC
Permitted range with signal "0" with signal "1"	10.8 ... 28.8 V DC max. 5 V DC min. 8.5 V DC	20.4 ... 28.8 V DC max. 5 V DC min. 12 V DC
Input current	1.5 mA	2 mA
Outputs	4 relays	4/8 transistors
Continuous current I _{th} (per terminal)	5 A with resistive load; 3 A with inductive load	0.3 A
Short-circuit protection	External fuse required	Electronic (approx. 1 A)
Switching frequency	2 Hz with resistive load; 0.5 Hz with inductive load	10 Hz
Power loss	0.3 ... 1.7 W at 12 V DC 0.4 ... 1.8 W at 24 V DC	0.8 ... 1.1 W* 0.8 ... 1.7 W**
Dimensions (W x H x D)	36 (2 MW) x 90 x 53 mm	36 (2 MW) x 90 x 53 mm 72 (4 MW) x 90 x 53 mm

LOGO! 230RC ¹⁾ , LOGO! 230RC _o ²⁾	LOGO! 12/24 RCE	LOGO! 230 RCE
8	8	8
–	4 (0 to 10 V)	–
115/240 V AC/DC	12/24 V DC	115/240 V AC/DC
85 ... 265 V AC 100 ... 253 V DC max. 40 V AC/30 V DC min. 79 V AC/79 V DC, 0.08 mA	10.8 V ... 28.8 V DC max. 5 V DC min. 8.5 V DC 1.5 mA (I3 ... I6) 0.1 mA (I1, I2, I7, I8)	85 ... 265 V AC 100 ... 253 V DC max. 40 V AC/30 V DC min. 79 V AC/79 V DC, 0.08 mA
4 relays	4 relays	4 relays
10 A with resistive load; 3 A with inductive load	10 A with resistive load; 3 A with inductive load	10 A with resistive load; 3 A with inductive load
External fuse required	External fuse required	External fuse required
2 Hz with resistive load; 0.5 Hz with inductive load	2 Hz with resistive load; 0.5 Hz with inductive load	2 Hz with resistive load; 0.5 Hz with inductive load
< 0.1 ms/function	< 0.1 ms/function	< 0.1 ms/function
Yes / typ. 80 h (2 years with battery module)	Yes / typ. 480 h; no battery	Yes / typ. 480 h; no battery

	On 35 mm standard mounting rail, 6 MW, or wall-mounting	
	108 (6 MW) x 90 x 55 mm (W x H x D)	108 (6 MW) x 90 x 55 mm (W x H x D)
LOGO! PC cable, (RS232 or USB)	Ethernet	Ethernet
Yes	No	No
No	Yes, max. 8 LOGO!s + 1PC/PG	Yes, max. 8 LOGO!s + 1PC/PG
No	Yes, max. 8 TN (LOGO!, SIMATIC CPU, 1x SIMATIC HMI, PC)	Yes, max. 8 TN (LOGO!, SIMATIC CPU, 1x SIMATIC HMI, PC)
200 blocks	400 blocks	400 blocks
LOGO! memory card	SIMATIC memory card or standard SD card max. 8 GB	SIMATIC memory card or standard SD card max. 8 GB
No	Internal memory/SD card	Internal memory/SD card
No	Yes, with saving on the PC	Yes, with saving on the PC
No	Yes	Yes

LOGO! DM8 24R DM16 24R	LOGO! DM8 230R DM16 230R
4/8	4/8
24 V AC/DC* 24 V DC**	115/240 V AC/DC
20.4 ... 28.8 V DC, 20.4 ... 26.4 V AC*	85 ... 265 V AC, 100 ... 253 V DC
max. 5 V AC/DC min. 12 V AC/DC*	max. 40 V AC min. 79 V AC
2.5 mA*, 2.0 mA**	0.08 mA
4/8 relays	4/8 relays
5 A with resistive load; 3 A with inductive load	5 A with resistive load; 3 A with inductive load
External fuse required	External fuse required
2 Hz with resistive load; 0.5 Hz with inductive load	2 Hz with resistive load; 0.5 Hz with inductive load
0.4 ... 1.8 W at 24 VDC* 0.9 ... 2.7 W at 24 VAC* 0.7 ... 2.5 W at 24 VDC**	1.1 ... 3.5 W (115 V AC) ... 4.5** 2.4 ... 4.8 W (240 V AC) ... 5.5** 0.5 ... 1.8 W (115 V DC) ... 2.9** 1.2 ... 2.4 W (240 V DC) ... 4.8**
36 (2 MW) x 90 x 53 mm 72 (4 MW) x 90 x 53 mm	36 (2 MW) x 90 x 53 mm 72 (4 MW) x 90 x 53 mm

R: Relay outputs, C: Clock/time switch,
o: without display

E: Ethernet interface

* for DM8 module, ** for DM16 module

1) As SIPLUS component also for extended temperature range – 25 ... +70 °C and corrosive atmosphere/condensation (www.siemens.com/siplus)

2) As SIPLUS component also for extended temperature range – 40 ... +70 °C and corrosive atmosphere/condensation (www.siemens.com/siplus)

LOGO! modular – the technical data

Analog modules	LOGO! AM2 ²⁾	LOGO! AM2 RTD	LOGO! AM2 AQ ²⁾
Supply voltage	12/24 V DC	12/24 V DC	24 V DC
Permitted range	10.8 ... 28.8 V DC	10.8 ... 28.8 V DC	20.4 ... 28.8 V DC
Analog inputs/outputs	2/0	2/0 x PT100 or PT1000 2-wire or 3-wire Automatic sensor detection	0/2
Measuring range		-50 °C ... +200 °C	-
Input range/output range	0 ... 10 V or 0/4 ... 20 mA	-	0 ... 10 V or 0/4 ... 20 mA
Resolution	10 bit standardized to 0–1000	0.25 °C	10 bit standardized to 0–1000
Cable length (shielded and twisted)	10 m	10 m	10 m
Encoder supply	none	1.1 mA	-
Power loss at 12 V DC at 24 V DC	0.3 ... 0.6 W 0.6 ... 1.2 W	0.3 ... 0.6 W 0.6 ... 1.2 W	- 0.6 ... 1.2 W
Dimensions (W x H x D)	36 (2 MW) x 90 x 53 mm	36 (2 MW) x 90 x 53 mm	36 (2 MW) x 90 x 53 mm

²⁾ As SIPLUS component also for extended temperature range -40 ... +70 °C and corrosive atmosphere/condensation (www.siemens.com/siplus)

LOGO! TD Text Display	
Supply voltage	12 V DC, 24 V AC/DC
Permitted range	10.2 ... 28.8 V DC or 20.4 to 26.4 V AC (47 ... 63 Hz)
Input	6 standard keys, 4 function keys (tactile-touch keys)
Display	61 x 33 mm, white, controllable backlight, adjustable contrast
Lines/characters	4 lines, 12/16 characters per line (depends on character set)
Length of connecting cable	2.5 m (extendable to 10 m with "universal" 9-wire standard serial cable)
Power consumption at 24 V DC	typ. 65 mA (12 V DC), typ. 40 mA (24 V DC), typ. 90 mA (24 V AC)
Cutout dimensions (W x H x D)	119.5 x 78.5 x 1.5 – 4.0 mm for panel mounting (128.3 x 86 x 38.7 mm total)

Communication modules (CM)	EIB/KNX	CM AS-Interface (slave)
Supply voltage	12/24 V DC	24 V DC
Permitted range	20.4 ... 28.8 V DC 20.4 ... 26.4 V AC	19.2 ... 28.8 V DC
Digital inputs*	16 (can also be configured as Monoflop)	4
Analog inputs*	8	-
Analog outputs*	2 (max. 8)	-
Digital outputs*	12	4
Dimensions (W x H x D)	2 MW 36 x 90 x 53 mm	2 MW 36 x 90 x 53 mm

* Mapping to LOGO! inputs/outputs

LOGO!

ordering data

LOGO! versions	Order No.
LOGO! 12/24 RCE	6ED1 052-1MD00-0BA7
LOGO! 230 RCE	6ED1 052-1FB00-0BA7
LOGO! 24 C	6ED1 052-1CC01-0BA6
LOGO! 24 Co	6ED1 052-2CC01-0BA6
LOGO! 12/24RC	6ED1 052-1MD00-0BA6
LOGO! 12/24RCo	6ED1 052-2MD00-0BA6
LOGO! 24RC (AC/DC)	6ED1 052-1HB00-0BA6
LOGO! 24RC (AC/DC)	6ED1 052-2HB00-0BA6
LOGO! 230RC	6ED1 052-1FB00-0BA6
LOGO! 230RCo	6ED1 052-2FB00-0BA6
LOGO! TD	6ED1 055-4MH00-0BA0

Expansion modules	Order No.
LOGO! DM8 24	6ED1 055-1CB00-0BA0
LOGO! DM8 12/24R	6ED1 055-1MB00-0BA1
LOGO! DM8 24R (AC/DC)	6ED1 055-1HB00-0BA0
LOGO! DM8 230R	6ED1 055-1FB00-0BA1
LOGO! DM16 24	6ED1 055-1CB10-0BA0
LOGO! DM16 24R	6ED1 055-1NB10-0BA0
LOGO! DM16 230R	6ED1 055-1FB10-0BA0
LOGO! AM2	6ED1 055-1MA00-0BA0
LOGO! AM2 RTD	6ED1 055-1MD00-0BA1
LOGO! AM2 AQ	6ED1 055-1MM00-0BA1

Communication modules	Order No.
LOGO! AS-i	3RK1 400-0CE10-0AA2
LOGO! EIB/KNX	6BK1 700-0BA00-0AA2

Optional accessories	Order No.
LOGO! Manual German	6ED1 050-1AA00-0AE8
LOGO! Manual English	6ED1 050-1AA00-0BE8
LOGO! Memory Card	6ED1 056-1DA00-0BA0
LOGO! Battery Card	6ED1 056-6XA00-0BA0
LOGO! Combo Memory & Battery Card	6ED1 056-7DA00-0BA0
LOGO! Soft Comfort V 7.0	6ED1 058-0BA02-0YA1
LOGO! Soft Comfort V 7.0 Upgrade	6ED1 058-0CA02-0YE1
LOGO! PC cable	6ED1 057-1AA00-0BA0
LOGO! USB PC cable	6ED1 057-1AA01-0BA0
LOGO! modem cable	6ED1 057-1CA00-0BA0

R: Relay outputs, C: Clock/time switch, o: without display

The products listed here may be subject to the current European/German and/or US export regulations.

LOGO! accessories



LOGO! PC cables/USB PC cables (only 0BA6)

For the simple transfer of LOGO! switching programs to and from PCs



LOGO! Switch

- For simple networking directly in the distribution board
- Provides 4 RJ45 ports, of which one is at the front

More information: www.siemens.com/logo-csm



LOGO! Manual

For intro to LOGO!

- Detailed information on operation
- Description of all integrated functions
- Many practical application examples
- Available in 6 languages



LOGO! Power

Reliable power supply for LOGO! – for converting the line voltage of 100/240 V AC to the respective operating voltage

- Suitable for all LOGO! 12 V DC and 24 V DC
- Versions for different output currents

More information: www.siemens.com/sitop



LOGO! Contact

Hum-free switching module

- For switching resistive loads up to 20 A
- For the direct switching of motors up to 4 kW
- For powerful loads in noise-sensitive areas

More information:

www.siemens.com/lowvoltage



LOGO! Prom (only 0BA6)

For replication of program modules

- For copying of modules
- For writing to modules via LOGO! Soft Comfort

More information: www.siemens.com/siplus



Front panel mounting frame

For installation in the control cabinet door

- Front IP65 (IP30 without glass)
- 4 MW or 8 MW (optional with keys)

More information: www.siemens.com/siplus



LOGO! Upmitter

For use with critical power supplies

Produces stable 24 V DC at the output with 8 to 59 V DC at the input

More information: www.siemens.com/siplus

Further information on LOGO! can be found on the Internet – under www.siemens.com/logo

- Comprehensive product information
- Free demonstration software
- Software upgrades
- Ready-to-use applications
- News
- Customer magazine GO!
- And much more

Of course, you can also purchase software, hardware or promotion packages for LOGO! online. In addition, on request you also find personal support under "Service and Support." We have compiled further example applications and configuration tools for you under www.siemens.com/microset.

SIPLUS LOGO! in the Internet

www.siemens.com/siplus

You can find hardened LOGO! modules there with

- extended temperature range
- protection against corrosive atmosphere/
condensation

Siemens AG
Industry Sector
Industry Automation
P.O. Box 48 48
90026 NUREMBERG
GERMANY

Subject to change without prior notice 02/12
Order No. E20001-A1120-P271-X-7600
Dispo 06307
WÜ/32480 MI.AS.LO.XXXX.52.2.02 021210.
Printed in Germany
© Siemens AG 2012

The information provided in this brochure contains merely general descriptions or characteristics of performance which in actual case of use do not always apply as described or which may change as a result of further development of the products. An obligation to provide the respective characteristics shall only exist if expressly agreed in the terms of contract. All product designations may be trademarks or product names of Siemens AG or supplier companies whose use by third parties for their own purposes could violate the rights of the owners.