

Table of length tolerances/ Tablica tolerancji dlugosci mm

Over/Od	Up to and including/ Do-wlacznie	Tolerance/Tolerancja +
0	305	+19
305	915	+45
915	1830	+56
1830	3660	+89
3660	7320	+165
7320	14640	+317
14640	30500	+622
30500		+2% of length/dlugosci

TABELA 1
CHART 1

NUMER MOLEX	WH P/N	L[mm]
* 1300130932	1R3D36I14C5003	500
* 1300130933	1R3D36I15C5003	500
1300130938	1R4D36E15C3003	300
1300130939	1R4D36E15C5003	500
1300130940	1R4D36I12C2003	200
* 1300130950	1R5D36E04C3003	300
1300130951	1R5D36E12C3003	300
1300130952	1R5D36I12C2003	200
1300130955	1R6D36E12C3003	300
1300130956	1R6D36E15C5003	500
* 1300135007	1R3D36E13C3003	300
* 1300138009	1R3D36E15C3003	300
* 1300138010	1R3D36E15C5003	500
1300138016	1R4D36E04C3003	300
1300138017	1R4D36I15C3003	300
1300138026	1R6D36E12C5003	500
1300138029	1R5D36I14C2003	200
1300138032	1R5D36E12M0203	2000
* 1300138041	1R3D36E05C3003	300

* PATRZ UWAGA 3
* SEE NOTE 3

⊗ OZNACZENIE PINU WIODACEGO
LEADING PIN

OZNACZENIE TYPOW KABLI,
* KTORZYCH DOTYCZY PLAN POLACZEN
MARKS OF CABLES TYPES
WHICH INVOLVE THE TABLE

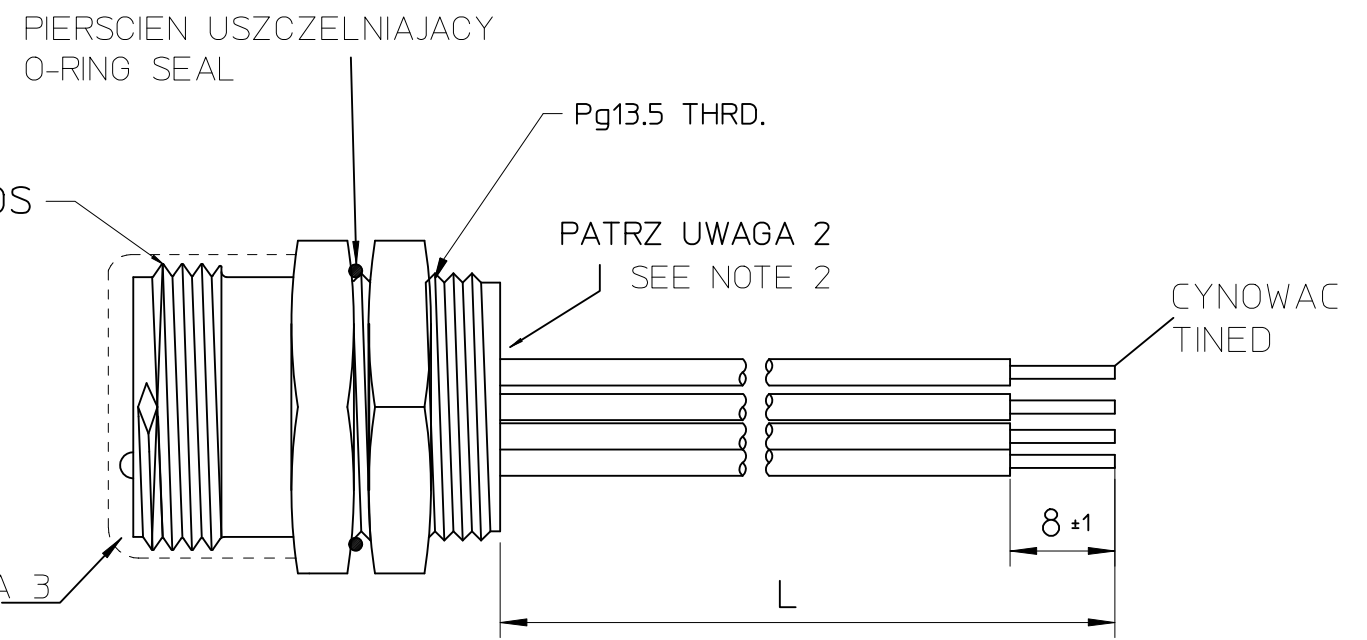
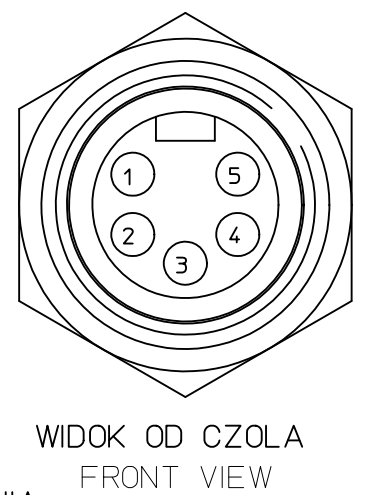
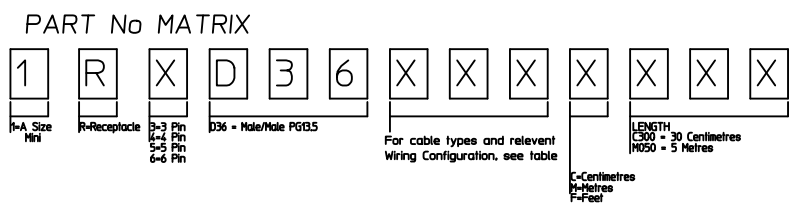

UWAGI:

- DLUGOSCI CIECIA PRZEWODOW I SPECYFIKACJE NABIJANIA W LISCIE CIECIA.
- PO OSADZENIU TERMINALI ZALAC KLEJEM.
- NALOZYC CZERWONA ZASLEPKA NA SHELL.

NOTES:

- FOR WIRES CUTTING LENGTHS AND CRIMPING SPECIFICATIONS SEE THE CUTTING LIST.
- AFTER ASSEMBLED TERMINALS THE CONNECTOR MUST BE FLOOD BY GLUE.
- PUT ON RED CAP ON SHELL.

UPDATE DRAWING EC NO: WEU2011-0278 DRWN: JANDZIAK 2010/12/06 CHKD: APPR: MWOLSZCZAK 2011/01/05	QUALITY SYMBOLS ▽=0 ▽=0	GENERAL TOLERANCES (UNLESS SPECIFIED)		DIMENSION STYLE MM ONLY		SCALE ---	DESIGN UNITS METRIC	FIRST ANGLE PROJECTION		
			mm	INCH	DRAWN BY JDAWIDOWICZ	DATE 2008/06/02	TITLE MC-XP-MM-REC-PG13.5-XXM			
		4 PLACES	± ---	± ---	CHECKED BY	DATE	MOLEX INCORPORATED E-130013-015 SHEET NO. 1 OF 1			
		3 PLACES	± ---	± ---	APPROVED BY	DATE				
ANGULAR ± ---°		DRAFT WHERE APPLICABLE MUST REMAIN WITHIN DIMENSIONS		MATERIAL NO. SEE CHART 1		DOCUMENT NO. E-130013-015				
SIZE A3		THIS DRAWING CONTAINS INFORMATION THAT IS PROPRIETARY TO MOLEX INCORPORATED AND SHOULD NOT BE USED WITHOUT WRITTEN PERMISSION								