

Front view and mounting

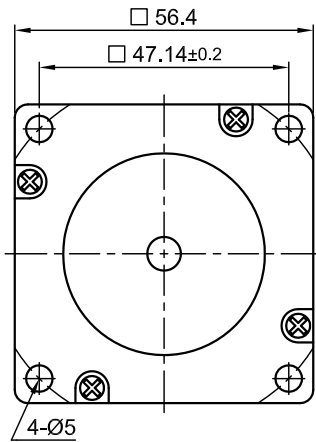

Side view

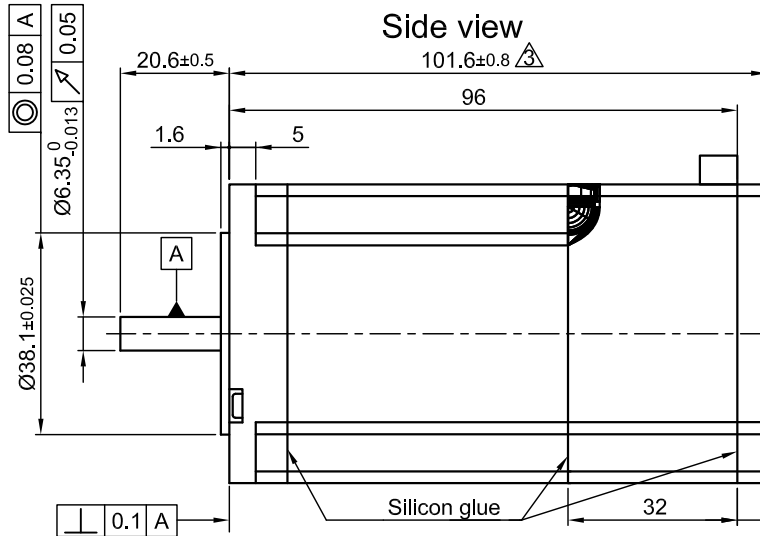

Rear view

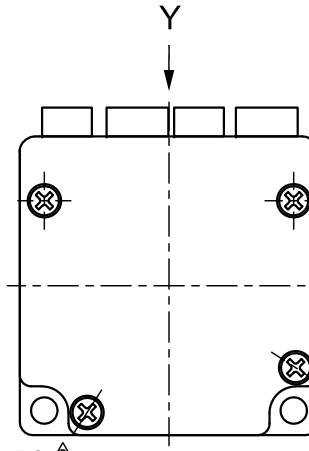

Y view

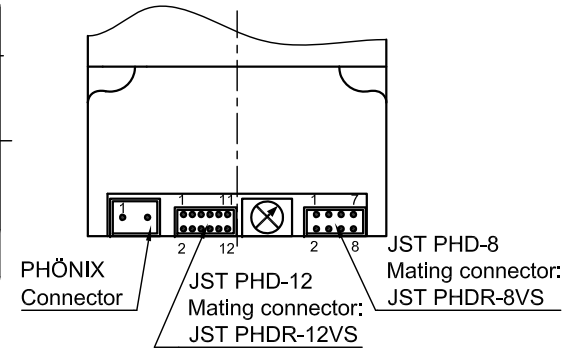

SPECIFICATION	CONNECTION	BIPOLAR PARALLEL
SUPPLY VOLTAGE (VDC)		24 TO 48
AMPS/PHASE		* UP TO 4.8 (100%=3.2)
HOLDING TORQUE (Nm) [lb-in]		1.98 [17.52]
DETENT TORQUE (Nm) [lb-in]		0.068 [0.602]
STEP ANGLE (°) ± ACCURACY		* 1.8 TO MICROSTEP
WEIGHT (Kg) [lb]		1.22 [6.54]

* ADJUSTABLE WITH NANOPRO.

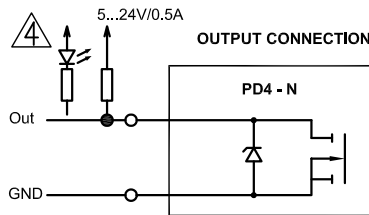
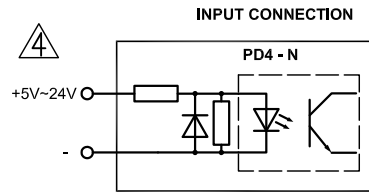

PERMISSIBLE RADIAL+AXIAL FORCE

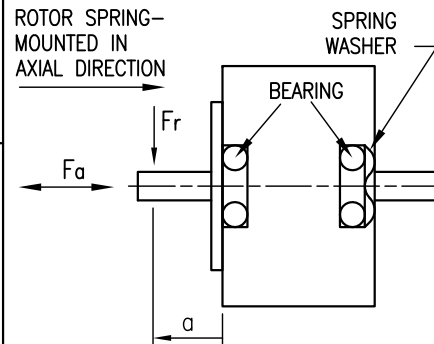

AXIAL-FORCE Fa (N)	Fa=10			
DISTANCE a (mm)	5	10	15	20
RADIAL-FORCE Fr (N)	130	90	70	52
		AXIAL	RADIAL	
SHAFT PLAY (mm)	0.08	0.02		
AT LOAD MAX: (N)	4.5	4.5		

JST PHDR-8VS		
PIN No.	WIRE COLOUR	ASSIGNMENT
1	BU	GND
2	WH-PK	+UB extern
3	YE	RS485 Rx-
4	GN	RS485 Rx+
5	PK	RS485 Tx-
6	GY	RS485 Tx+
7	BN	CAN+
8	WH	CAN-

JST PHDR-12VS		
PIN No.	WIRE COLOUR	ASSIGNMENT
1	GY-BN	COM
2	RD	GND
3	BK	INPUT 1
4	VT	INPUT 2
5	GY-PK	INPUT 3
6	RD-BU	INPUT 4
7	WH-GN	INOUT 5
8	BN-GN	INPUT 6
9	WH-BU	ANALOG INPUT
10	WH-YE	OUTPUT 1
11	YE-BN	OUTPUT 2
12	WH-GY	OUTPUT 3

FK-MCP-1.5/2-ST-3.5 gn		
PIN No.	WIRE COLOUR	ASSIGNMENT
1	BK	GND
2	BN	Vcc

FULL STEP 2 PHASE-Ex., WHEN FACING MOUNTING END (X)

STEP	A	B	A\	B\	CCW	CW
1	+	+	-	-	↓	↑
2	-	+	+	-	↑	↓
3	-	-	+	+	↓	↑
4	+	-	-	+	↑	↓

CABLE SET:
ZK-PD4N
L=500mm

OVERTEMPERATURE PROTECTION (ELECTRONICS): 80°C			
AMBIENT TEMPERATURE -10°~ 40°C [14°F ~ 104°F] (HIGHER TEMPERATURE REDUCES DUTY CYCLE)			
INSULATION RESISTANCE 100 MOhm (UNDER NORMAL TEMPERATURE AND HUMIDITY)			
INSULATION CLASS B 130° [266°F]			
DIELECTRIC STRENGTH 500VAC FOR 1 MIN. (BETWEEN THE MOTOR COILS AND THE MOTOR CASE)			
AMBIENT HUMIDITY MAX. 85% (NO CONDENSATION)			

3	MOTOR LENGTH	20.07.10.	J.W.
2	NEW VALUE OF ADJUSTABLE CURRENT	07.04.10.	J.W.
4	NEW CONNECTION OF IN-, OUTPUT	07.09.10.	J.W.
REV	DESCRIPTION	DATE	APVD



PD4-N5918L4204

SCALE FREE	APVD	S.Ha.	30.10.09
X ±0.5	CHKD		
1PL ±0.2	DRN	J.W.	30.10.09
2PL ±0.1	SIGNATURE		
ANGLE ±30'	DATE		

PLUG&DRIVE MOTOR	
DWG.NO	PD4-N5918L4204