

## LEVEL-TRANSLATING I<sup>2</sup>C/SMBUS BUS REPEATER

Check for Samples: [TCA9509](#)

### FEATURES

- Two-Channel Bidirectional Buffer
- I<sup>2</sup>C Bus and SMBus Compatible
- Operating Supply Voltage Range of 2.7 V to 5.5 V on B side
- Operating Voltage Range of 0.9 V to  $V_{CCB} - 1V$  on A Side
- Voltage-Level Translation From 0.9 V to ( $V_{CCB} - 1V$ ) and 2.7 V to 5.5 V
- Active-High Repeater-Enable Input
- Requires no external pull-up resistors on lower-voltage port-A
- Open-Drain I<sup>2</sup>C I/O
- 5.5-V Tolerant I<sup>2</sup>C and Enable Input Support Mixed-Mode Signal Operation
- Lockup-Free Operation
- Accommodates Standard Mode and Fast Mode I<sup>2</sup>C Devices and Multiple Masters
- Supports Arbitration and Clock Stretching Across Repeater
- Powered-Off High-Impedance I<sup>2</sup>C bus pins
- Supports 400-kHz Fast I<sup>2</sup>C Bus operating speeds
- Available in
  - 1.6mm x 1.6mm, 0.4mm height, 0.5mm pitch QFN pkg
  - 3mm x 3mm industry standard MSOP pkg
- Latch-Up Performance Exceeds 100 mA Per JESD 78, Class II
- ESD Protection Exceeds JESD 22
  - 2000-V Human-Body Model (A114-A)
  - 1000-V Charged-Device Model (C101)

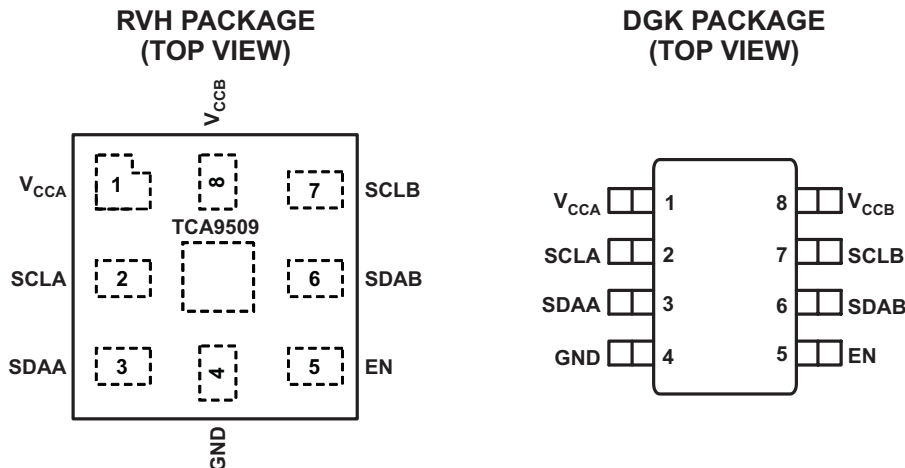

### DESCRIPTION/ORDERING INFORMATION

This TCA9509 integrated circuit is an I<sup>2</sup>C bus/SMBus Repeater for use in I<sup>2</sup>C/SMBus systems. It can also provide bidirectional voltage-level translation (up-translation/down-translation) between low voltages (down to 0.9 V) and higher voltages (2.7 V to 5.5 V) in mixed-mode applications. This device enables I<sup>2</sup>C and similar bus systems to be extended, without degradation of performance even during level shifting.

The TCA9509 buffers both the serial data (SDA) and the serial clock (SCL) signals on the I<sup>2</sup>C bus, thus allowing 400-pF bus capacitance on the B-side. This device can also be used to isolate two halves of a bus for voltage and capacitance.

The TCA9509 has two types of drivers – A-side drivers and B-side drivers. All inputs and B-side I/O's are overvoltage tolerant to 5.5V. The A-side I/O's are overvoltage tolerant to 5.5V when the device is unpowered ( $V_{CCB}$  and/or  $V_{CCA}=0V$ ).



Please be aware that an important notice concerning availability, standard warranty, and use in critical applications of Texas Instruments semiconductor products and disclaimers thereto appears at the end of this data sheet.

**ORDERING INFORMATION**

$T_A$	ORDERABLE PART NUMBERS	PACKAGES <sup>(1)</sup> <sup>(2)</sup>		TOP-SIDE MARKING
–40°C to 85°C	TCA9509RVHR	RVH - QFN	Tape and reel	7K
–40°C to 85°C	TCA9509DGKR	DGK - MSOP	Tape and reel	7KQ

(1) Package drawings, thermal data, and symbolization are available at [www.ti.com/packaging](http://www.ti.com/packaging).

(2) For the most current package and ordering information, see the Package Option Addendum at the end of this document, or see the TI website at [www.ti.com](http://www.ti.com).

**DESCRIPTION/ORDERING INFORMATION (CONTINUED)**

The bus port B drivers are compliant with SMBus I/O levels, while the A side uses a current sensing mechanism to detect the input or output LOW signal which prevents bus lock-up. The A side uses a 1 mA current source for pull-up and a 200  $\Omega$  pull-down driver. This results in a LOW on the A side accommodating smaller voltage swings. The output pull-down on the A side internal buffer LOW is set for approximately 0.2 V, while the input threshold of the internal buffer is set about 50 mV lower than that of the output voltage LOW. When the A side I/O is driven LOW internally, the LOW is not recognized as a LOW by the input. This prevents a lock-up condition from occurring. The output pull-down on the B side drives a hard LOW and the input level is set at 0.3 of SMBus or I<sup>2</sup>C-bus voltage level which enables B side to connect to any other I<sup>2</sup>C-bus devices or buffer.

The TCA9509 drivers are not enabled unless  $V_{CCA}$  is above 0.8 V and  $V_{CCB}$  is above 2.5 V. The enable (EN) pin can also be used to turn the drivers on and off under system control. Caution should be observed to only change the state of the EN pin when the bus is idle.

an

**TERMINAL FUNCTIONS**

NO.	NAME	DESCRIPTION
1	V <sub>CCA</sub>	A-side supply voltage (0.9V to V <sub>CCB</sub> - 1V)
2	SCLA	Serial clock bus, A side.
3	SDAA	Serial data bus, A side.
4	GND	Supply ground
5	EN	Active-high repeater enable input
6	SDAB	Serial data bus, B side. Connect to V <sub>CCB</sub> through a pullup resistor.
7	SCLB	Serial clock bus, B side. Connect to V <sub>CCB</sub> through a pullup resistor.
8	V <sub>CCB</sub>	B-side and device supply voltage (2.7 V to 5.5 V)

**Table 1. FUNCTION TABLE**

INPUT EN	FUNCTION
L	Outputs disabled
H	SDAA = SDAB SCLA = SCLB

**Figure 1. FUNCTIONAL BLOCK DIAGRAM**

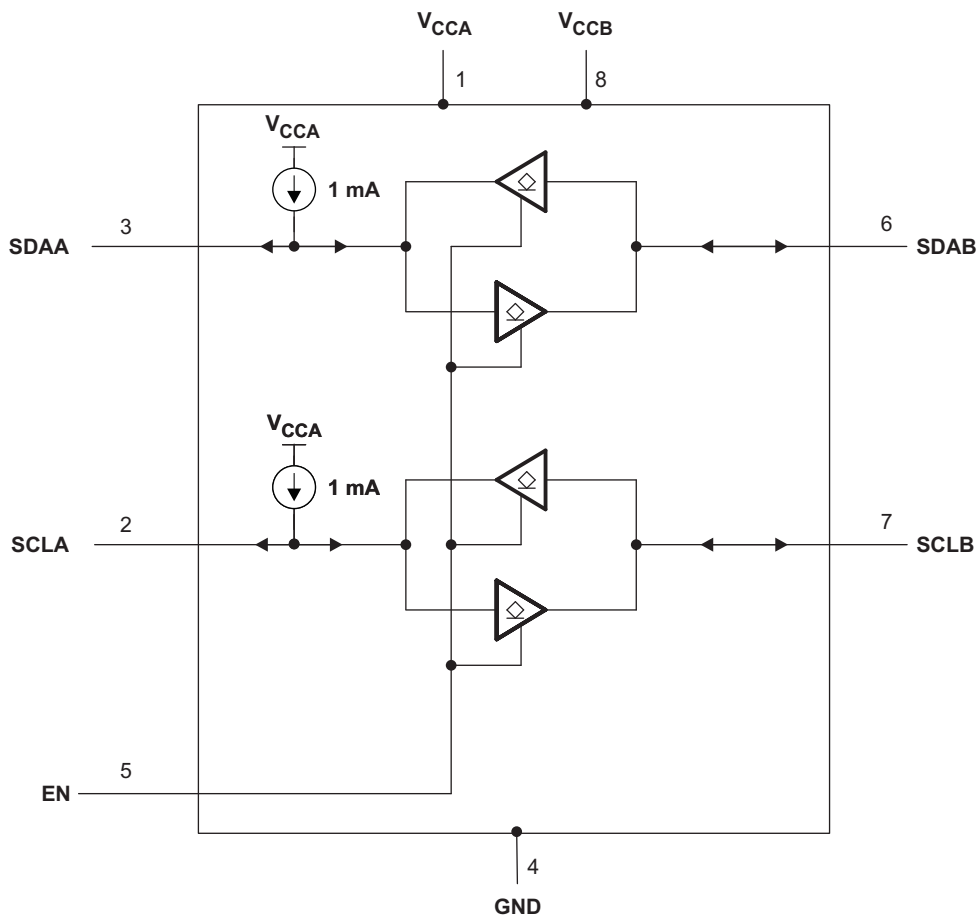

**ABSOLUTE MAXIMUM RATINGS<sup>(1)</sup>**

over operating free-air temperature range (unless otherwise noted)

		MIN	MAX	UNIT
V <sub>CCB</sub>	Supply voltage range	-0.5	6	V
V <sub>CCA</sub>	Supply voltage range	-0.5	6	V
V <sub>I</sub>	Enable input voltage range <sup>(2)</sup>	-0.5	6	V
V <sub>I/O</sub>	I <sup>2</sup> C bus voltage range <sup>(2)</sup>	-0.5	6	V
I <sub>IK</sub>	Input clamp current	V <sub>I</sub> < 0	-20	mA
I <sub>OK</sub>	Output clamp current	V <sub>O</sub> < 0	-20	
P <sub>d</sub>	Max power dissipation		100	mW
T <sub>stg</sub>	Storage temperature range	-65	150	°C

- (1) Stresses beyond those listed under "absolute maximum ratings" may cause permanent damage to the device. These are stress ratings only, and functional operation of the device at these or any other conditions beyond those indicated under "recommended operating conditions" is not implied. Exposure to absolute-maximum-rated conditions for extended periods may affect device reliability.
- (2) The input negative-voltage and output voltage ratings may be exceeded if the input and output current ratings are observed.

**THERMAL IMPEDANCE**

over operating free-air temperature range (unless otherwise noted)

			UNIT
θ <sub>JA</sub>	Package thermal impedance <sup>(1)</sup>	RVH package	208.99 °C/W
		DGK package	222.9 °C/W

- (1) The package thermal impedance is calculated in accordance with JESD 51-7.

**RECOMMENDED OPERATING CONDITIONS**

		MIN	MAX	UNIT
V <sub>CCA</sub>	Supply voltage, A-side bus	0.9 <sup>(1)</sup>	V <sub>CCB</sub> - 1	V
V <sub>CCB</sub>	Supply voltage, B-side bus	2.7	5.5	V
V <sub>IH</sub>	High-level input voltage	SDAA, SCLA	0.7 × V <sub>CCA</sub>	V <sub>CCA</sub>
		SDAB, SCLB	0.7 × V <sub>CCB</sub>	5.5
		EN	0.7 × V <sub>CCA</sub>	5.5
V <sub>IL</sub>	Low-level input voltage	SDAA, SCLA	-0.5	0.3
		SDAB, SCLB	-0.5	0.3 × V <sub>CCB</sub>
		EN	-0.5	0.3 × V <sub>CCA</sub>
I <sub>OL</sub>	Low-level output current	SDAA, SCLA		10 μA
		SDAB, SCLB		6 mA
T <sub>A</sub>	Operating free-air temperature	-40	85	°C

- (1) Low-level supply voltage

## ELECTRICAL CHARACTERISTICS

 $V_{CCB} = 2.7\text{ V to }5.5\text{ V}$ ,  $V_{CCA} = 0.9\text{ V to } (V_{CCB}-1)$ ,  $T_A = -40^\circ\text{C to }85^\circ\text{C}$  (unless otherwise noted)

PARAMETER		TEST CONDITIONS	MIN	TYP	MAX	UNIT	
$V_{IK}$	Input clamp voltage	$I_I = -18\text{ mA}$	-1.5		-0.5	V	
$V_{OL}$	Low-level output voltage	SDAA, SCLA $I_{OL} = 10\ \mu\text{A}$ , $V_{ILA} = V_{ILB} = 0\text{ V}$ , $V_{CCA} = 0.9\text{ to }1.2\text{V}$		0.18	0.25	V	
		SDAA, SCLA $I_{OL} = 20\ \mu\text{A}$ , $V_{ILA} = V_{ILB} = 0\text{ V}$ , $1.2\text{V} < V_{CCA} \leq (V_{CCB} - 1\text{V})$		0.2	0.3		
$V_{OL} - V_{ILc}$	Low-level input voltage below low-level output voltage	SDAA, SCLA		50		mV	
$V_{ILc}$	SDA and SCL low-level input voltage contention	SDAA, SCLA	-0.5	0.15		V	
$V_{OLB}$	Low-level output voltage	SDAB, SCLB		0.1	0.2	V	
$I_{CC}$	Quiescent supply current for $V_{CCA}$	All port A Static high	0.25	0.45	0.9	mA	
		All port A Static low	1.25	3	5		
$I_{CC}$	Quiescent supply current for $V_{CCB}$	All port B Static high	0.5	0.9	1.1	mA	
$I_I$	Input leakage current	SDAB, SCLB	$V_I = V_{CCB}$		$\pm 1$	$\mu\text{A}$	
			$V_I = 0.2\text{ V}$		10		
		SDAA, SCLA	$V_I = V_{CCA}$		$\pm 1$		
			$V_I = 0.2\text{ V}$		10		
		EN	$V_I = V_{CCB}$		$\pm 1$		
			$V_I = 0.2\text{ V}$		-10		
$I_{OH}$	High-level output leakage current	SDAB, SCLB	$V_O = 3.6\text{ V}$		10	$\mu\text{A}$	
		SDAA, SCLA			10		
$C_{IOA}$	I/O capacitance of A-side	SCLA, SDAA	$V_I = 0\text{ V}$	6	6.5	7	pF
$C_{IOB}$	I/O capacitance of B-side	SCLB, SDAB	$V_I = 0\text{ V}$	5.5	6	6.2	pF

## TIMING REQUIREMENTS

over recommended operating free-air temperature range (unless otherwise noted)

	MIN	MAX	UNIT
$t_{su}$ Setup time, EN high before Start condition <sup>(1)</sup>	100		ns
$t_h$ Hold time, EN high after Stop condition <sup>(1)</sup>	100		ns

(1) EN should change state only when the global bus and the repeater port are in an idle state.

## I<sup>2</sup>C INTERFACE TIMING REQUIREMENTS

T<sub>A</sub> = –40°C to 85°C (unless otherwise noted)

PARAMETER			V <sub>CCA</sub> (INPUT)	V <sub>CCB</sub> (OUTPUT)	TEST CONDITIONS	MIN	TYP <sup>(1)</sup>	MAX	UNIT
t <sub>PHL</sub>	Propagation delay	port A to port B	1.9 V	5.0 V	EN High	123.1	127.2	132.8	ns
		port B to port A				88.1	88.8	89.8	
t <sub>PLH</sub>	Propagation delay	port A to port B	1.9 V	5.0 V	EN High	122.6	125.7	131.7	ns
		port B to port A				123.0	124.1	126.9	
t <sub>rise</sub>	Transition time	port A	1.9 V	5.0 V	EN High	40.1	40.9	41.9	ns
		port B				57.3	57.5	58.4	
t <sub>fall</sub>	Transition time	port A	1.9 V	5.0 V	EN High	14.5	16.4	17.9	ns
		port B				18.7	19.4	20.2	
t <sub>PLH2</sub>	Propagation delay 50% of initial low on Port A to 1.5 V on Port B	port A to port B	1.9 V	5.0 V		176.0	177.3	178.0	ns
f <sub>MAX</sub>	Maximum switching frequency					400			KHz

(1) Typical values were measured with V<sub>CCA</sub> = V<sub>CCB</sub> = 2.7 V at T<sub>A</sub> = 25°C, unless otherwise noted.

### PARAMETER MEASUREMENT INFORMATION

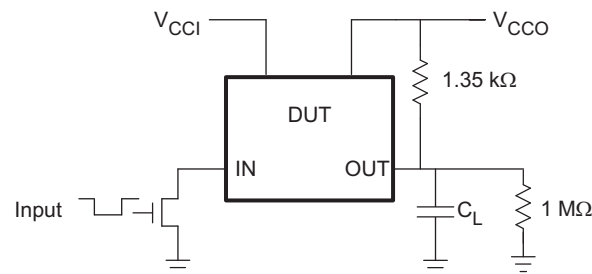

PIN	C <sub>L</sub>
SCLA, SDAA (A side)	50 pF
SDAB, SCLB (B side)	50 pF

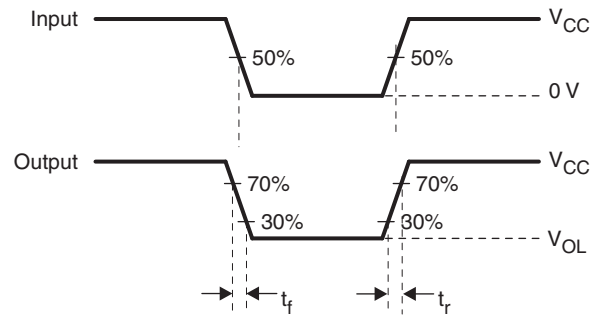

- A.  $R_T$  termination resistance should be equal to  $Z_{OUT}$  of pulse generators.
- B.  $C_L$  includes probe and jig capacitance.
- C. All input pulses are supplied by generators having the following characteristics:  $PRR \leq 10$  MHz,  $Z_O = 50 \Omega$ , slew rate  $\geq 1$  V/ns.
- D. The outputs are measured one at a time, with one transition per measurement.
- E.  $t_{PLH}$  and  $t_{PHL}$  are the same as  $t_{pd}$ .

**Figure 2. Test Circuit and Voltage Waveforms**

## APPLICATION INFORMATION

A typical application is shown in [Figure 3](#). In this example, the system master is running on a 1.1-V I<sup>2</sup>C bus, and the slave is connected to a 3.3-V bus. Both buses run at 400 kHz. Master devices can be placed on either bus.

The TCA9509 is 5-V tolerant, so it does not require any additional circuitry to translate between 0.9-V to 5.5-V bus voltages and 2.7-V to 5.5-V bus voltages.

When the B side of the TCA9509 is pulled low by a driver on the I<sup>2</sup>C bus and the falling edge goes below 0.3 V<sub>CCB</sub>, it causes the internal driver on the A side to turn on, causing the A side to pull down to about 0.2 V. When the A side of the TCA9509 falls, first a comparator detects the falling edge and causes the internal driver on the B side to turn on and pull the B-side pin down to ground. In order to illustrate what would be seen in a typical application, refer to [Figure 4](#) and [Figure 5](#). If the bus master in [Figure 3](#) were to write to the slave through the TCA9509, waveforms shown in [Figure 4](#) would be observed on the B bus. This looks like a normal I<sup>2</sup>C bus transmission, except that the high level may be as low as 0.9 V, and the turn on and turn off of the acknowledge signals are slightly delayed.

On the A-side bus of the TCA9509, the clock and data lines would have a positive offset from ground equal to the V<sub>OL</sub> of the TCA9509. After the eighth clock pulse, the data line is pulled to the V<sub>OL</sub> of the master device, which is very close to ground in this example. At the end of the acknowledge, the level rises only to the low level set by the driver in the TCA9509 for a short delay, while the B-bus side rises above 0.3 V<sub>CCB</sub> and then continues high. It is important to note that any arbitration or clock stretching events require that the low level on the A-bus side at the input of the TCA9509 (V<sub>IL</sub>) be at or below 0.15 V to be recognized by the TCA9509 and then transmitted to the B-bus side.

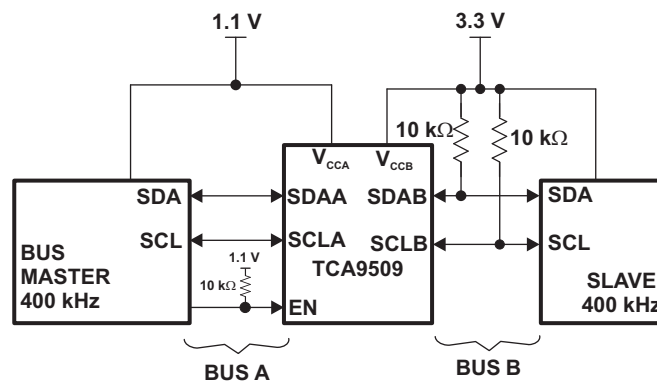

Figure 3. Typical Application

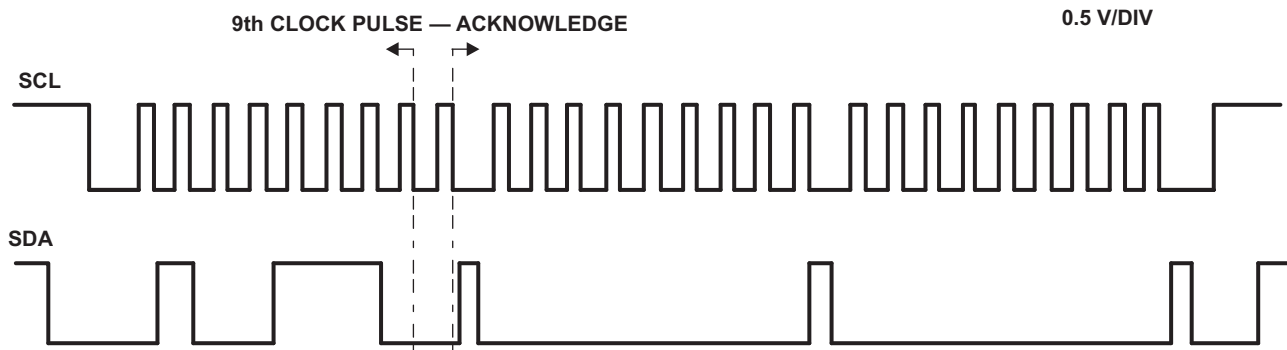

Figure 4. Bus A (0.9-V to 5.5-V Bus) Waveform



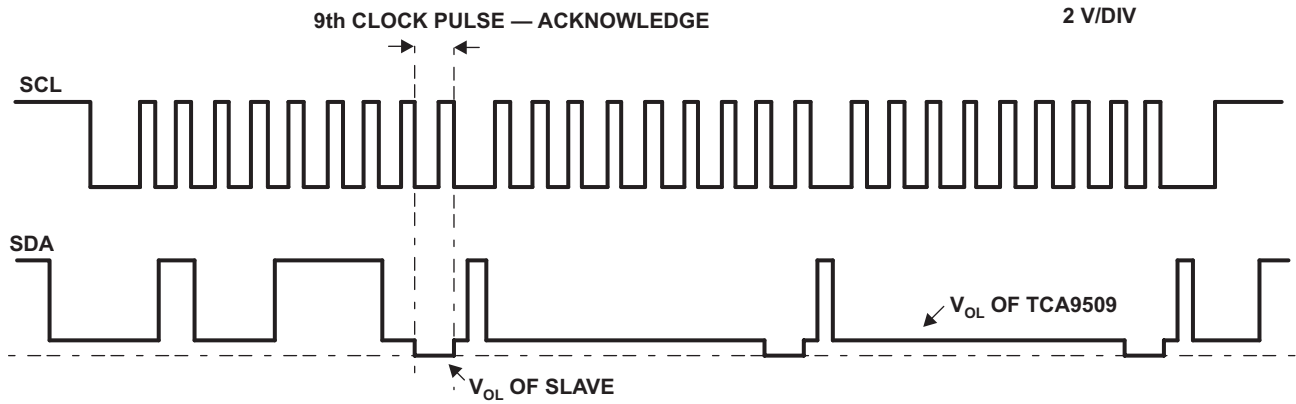

Figure 5. Bus B (2.7-V to 5.5-V Bus) Waveform

## REVISION HISTORY

<b>Changes from Original (August 2011) to Revision A</b>	<b>Page</b>
• Corrected $V_{CCA}$ operating voltage lower limit, to 0.9V at multiple instances in document. ....	1
• Changed Operating Supply Voltage Range value error in FEATURES for B side. Changed from (0.9 V to 5.5 V on B side) to (2.7 V to 5.5 V on B side). ....	1
• Changed Operating Voltage Range value error in FEATURES for A side. Changed (2.7 V to $V_{CCB} - 1$ V on A side) to (0.9 V to $V_{CCB} - 1$ V on A side). ....	1

<b>Changes from Revision A (October 2011) to Revision B</b>	<b>Page</b>
• Added DGK package and package information to datasheet. ....	1

**PACKAGING INFORMATION**

Orderable Device	Status <sup>(1)</sup>	Package Type	Package Drawing	Pins	Package Qty	Eco Plan <sup>(2)</sup>	Lead/ Ball Finish	MSL Peak Temp <sup>(3)</sup>	Samples (Requires Login)
TCA9509DGKR	ACTIVE	MSOP	DGK	8	2500	Green (RoHS & no Sb/Br)	CU NIPDAUAG	Level-1-260C-UNLIM	
TCA9509RVHR	ACTIVE	X2QFN	RVH	8	5000	Green (RoHS & no Sb/Br)	CU NIPDAU	Level-1-260C-UNLIM	

<sup>(1)</sup> The marketing status values are defined as follows:

**ACTIVE:** Product device recommended for new designs.

**LIFEBUY:** TI has announced that the device will be discontinued, and a lifetime-buy period is in effect.

**NRND:** Not recommended for new designs. Device is in production to support existing customers, but TI does not recommend using this part in a new design.

**PREVIEW:** Device has been announced but is not in production. Samples may or may not be available.

**OBsolete:** TI has discontinued the production of the device.

<sup>(2)</sup> Eco Plan - The planned eco-friendly classification: Pb-Free (RoHS), Pb-Free (RoHS Exempt), or Green (RoHS & no Sb/Br) - please check <http://www.ti.com/productcontent> for the latest availability information and additional product content details.

**TBD:** The Pb-Free/Green conversion plan has not been defined.

**Pb-Free (RoHS):** TI's terms "Lead-Free" or "Pb-Free" mean semiconductor products that are compatible with the current RoHS requirements for all 6 substances, including the requirement that lead not exceed 0.1% by weight in homogeneous materials. Where designed to be soldered at high temperatures, TI Pb-Free products are suitable for use in specified lead-free processes.

**Pb-Free (RoHS Exempt):** This component has a RoHS exemption for either 1) lead-based flip-chip solder bumps used between the die and package, or 2) lead-based die adhesive used between the die and leadframe. The component is otherwise considered Pb-Free (RoHS compatible) as defined above.

**Green (RoHS & no Sb/Br):** TI defines "Green" to mean Pb-Free (RoHS compatible), and free of Bromine (Br) and Antimony (Sb) based flame retardants (Br or Sb do not exceed 0.1% by weight in homogeneous material)

<sup>(3)</sup> MSL, Peak Temp. -- The Moisture Sensitivity Level rating according to the JEDEC industry standard classifications, and peak solder temperature.

**Important Information and Disclaimer:** The information provided on this page represents TI's knowledge and belief as of the date that it is provided. TI bases its knowledge and belief on information provided by third parties, and makes no representation or warranty as to the accuracy of such information. Efforts are underway to better integrate information from third parties. TI has taken and continues to take reasonable steps to provide representative and accurate information but may not have conducted destructive testing or chemical analysis on incoming materials and chemicals. TI and TI suppliers consider certain information to be proprietary, and thus CAS numbers and other limited information may not be available for release.

In no event shall TI's liability arising out of such information exceed the total purchase price of the TI part(s) at issue in this document sold by TI to Customer on an annual basis.

**TAPE AND REEL INFORMATION**
**REEL DIMENSIONS**

**TAPE DIMENSIONS**

A0	Dimension designed to accommodate the component width
B0	Dimension designed to accommodate the component length
K0	Dimension designed to accommodate the component thickness
W	Overall width of the carrier tape
P1	Pitch between successive cavity centers

**TAPE AND REEL INFORMATION**

\*All dimensions are nominal

Device	Package Type	Package Drawing	Pins	SPQ	Reel Diameter (mm)	Reel Width W1 (mm)	A0 (mm)	B0 (mm)	K0 (mm)	P1 (mm)	W (mm)	Pin1 Quadrant
TCA9509DGKR	MSOP	DGK	8	2500	330.0	12.4	5.3	3.4	1.4	8.0	12.0	Q1
TCA9509RVHR	X2QFN	RVH	8	5000	180.0	9.5	1.73	1.73	0.72	4.0	8.0	Q2

**TAPE AND REEL BOX DIMENSIONS**

\*All dimensions are nominal

Device	Package Type	Package Drawing	Pins	SPQ	Length (mm)	Width (mm)	Height (mm)
TCA9509DGKR	MSOP	DGK	8	2500	364.0	364.0	27.0
TCA9509RVHR	X2QFN	RVH	8	5000	180.0	180.0	30.0

DGK (S-PDSO-G8)

PLASTIC SMALL-OUTLINE PACKAGE



- NOTES:
- A. All linear dimensions are in millimeters.
  - B. This drawing is subject to change without notice.
  - C. Body length does not include mold flash, protrusions, or gate burrs. Mold flash, protrusions, or gate burrs shall not exceed 0.15 per end.
  - D. Body width does not include interlead flash. Interlead flash shall not exceed 0.50 per side.
  - E. Falls within JEDEC MO-187 variation AA, except interlead flash.







RVH (S-PX2QFN-N8)

PLASTIC SMALL OUTLINE NO-LEAD

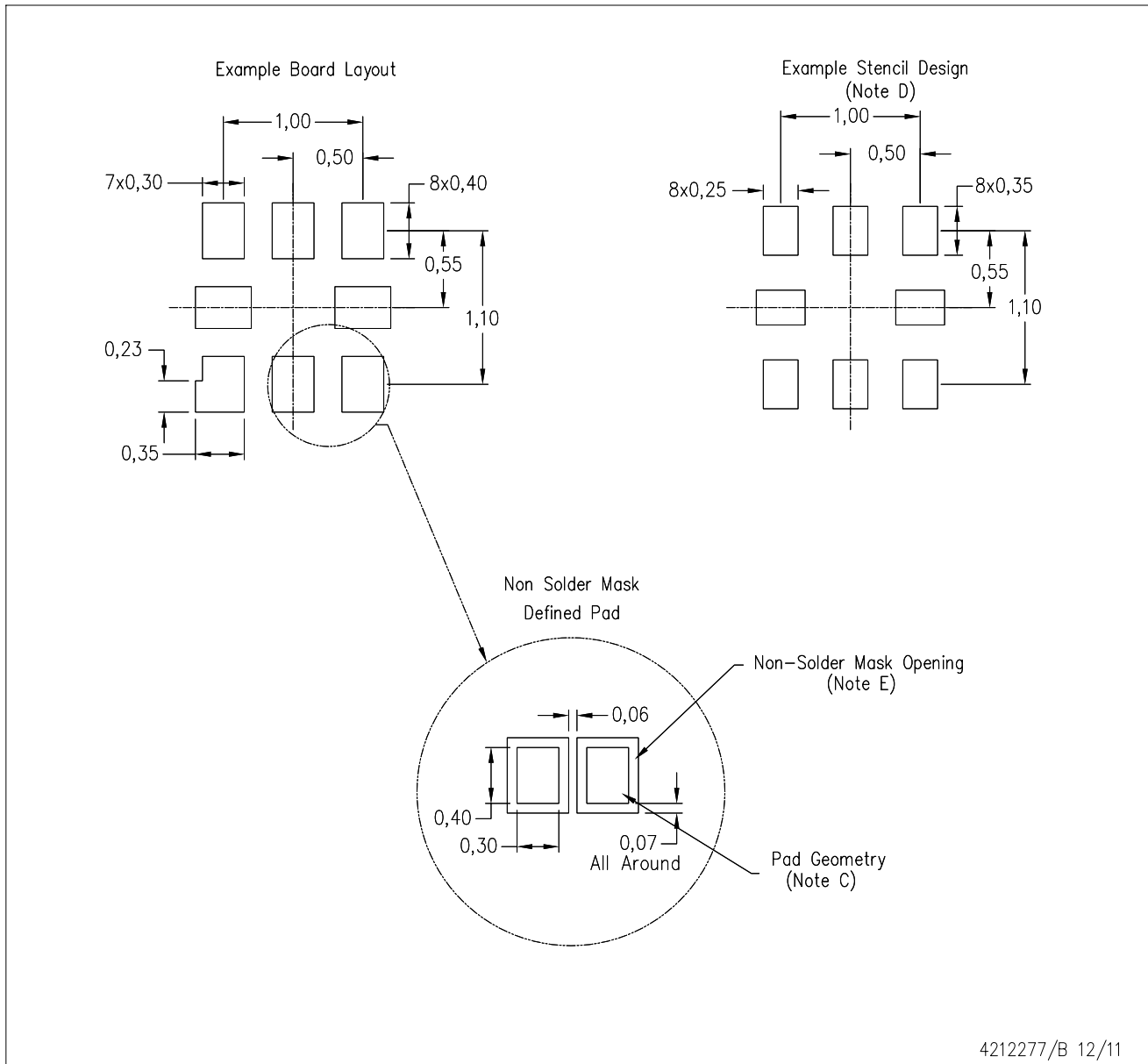

- NOTES:
- All linear dimensions are in millimeters.
  - This drawing is subject to change without notice.
  - Publication IPC-7351 is recommended for alternate designs.
  - Laser cutting apertures with trapezoidal walls and also rounding corners will offer better paste release. Customers should contact their board assembly site for stencil design recommendations. Refer to IPC 7525 for stencil design considerations.
  - Customers should contact their board fabrication site for minimum solder mask web tolerances between signal pads.

## IMPORTANT NOTICE

Texas Instruments Incorporated and its subsidiaries (TI) reserve the right to make corrections, modifications, enhancements, improvements, and other changes to its products and services at any time and to discontinue any product or service without notice. Customers should obtain the latest relevant information before placing orders and should verify that such information is current and complete. All products are sold subject to TI's terms and conditions of sale supplied at the time of order acknowledgment.

TI warrants performance of its hardware products to the specifications applicable at the time of sale in accordance with TI's standard warranty. Testing and other quality control techniques are used to the extent TI deems necessary to support this warranty. Except where mandated by government requirements, testing of all parameters of each product is not necessarily performed.

TI assumes no liability for applications assistance or customer product design. Customers are responsible for their products and applications using TI components. To minimize the risks associated with customer products and applications, customers should provide adequate design and operating safeguards.

TI does not warrant or represent that any license, either express or implied, is granted under any TI patent right, copyright, mask work right, or other TI intellectual property right relating to any combination, machine, or process in which TI products or services are used. Information published by TI regarding third-party products or services does not constitute a license from TI to use such products or services or a warranty or endorsement thereof. Use of such information may require a license from a third party under the patents or other intellectual property of the third party, or a license from TI under the patents or other intellectual property of TI.

Reproduction of TI information in TI data books or data sheets is permissible only if reproduction is without alteration and is accompanied by all associated warranties, conditions, limitations, and notices. Reproduction of this information with alteration is an unfair and deceptive business practice. TI is not responsible or liable for such altered documentation. Information of third parties may be subject to additional restrictions.

Resale of TI products or services with statements different from or beyond the parameters stated by TI for that product or service voids all express and any implied warranties for the associated TI product or service and is an unfair and deceptive business practice. TI is not responsible or liable for any such statements.

TI products are not authorized for use in safety-critical applications (such as life support) where a failure of the TI product would reasonably be expected to cause severe personal injury or death, unless officers of the parties have executed an agreement specifically governing such use. Buyers represent that they have all necessary expertise in the safety and regulatory ramifications of their applications, and acknowledge and agree that they are solely responsible for all legal, regulatory and safety-related requirements concerning their products and any use of TI products in such safety-critical applications, notwithstanding any applications-related information or support that may be provided by TI. Further, Buyers must fully indemnify TI and its representatives against any damages arising out of the use of TI products in such safety-critical applications.

TI products are neither designed nor intended for use in military/aerospace applications or environments unless the TI products are specifically designated by TI as military-grade or "enhanced plastic." Only products designated by TI as military-grade meet military specifications. Buyers acknowledge and agree that any such use of TI products which TI has not designated as military-grade is solely at the Buyer's risk, and that they are solely responsible for compliance with all legal and regulatory requirements in connection with such use.

TI products are neither designed nor intended for use in automotive applications or environments unless the specific TI products are designated by TI as compliant with ISO/TS 16949 requirements. Buyers acknowledge and agree that, if they use any non-designated products in automotive applications, TI will not be responsible for any failure to meet such requirements.

Following are URLs where you can obtain information on other Texas Instruments products and application solutions:

### Products

Audio	<a href="http://www.ti.com/audio">www.ti.com/audio</a>
Amplifiers	<a href="http://amplifier.ti.com">amplifier.ti.com</a>
Data Converters	<a href="http://dataconverter.ti.com">dataconverter.ti.com</a>
DLP® Products	<a href="http://www.dlp.com">www.dlp.com</a>
DSP	<a href="http://dsp.ti.com">dsp.ti.com</a>
Clocks and Timers	<a href="http://www.ti.com/clocks">www.ti.com/clocks</a>
Interface	<a href="http://interface.ti.com">interface.ti.com</a>
Logic	<a href="http://logic.ti.com">logic.ti.com</a>
Power Mgmt	<a href="http://power.ti.com">power.ti.com</a>
Microcontrollers	<a href="http://microcontroller.ti.com">microcontroller.ti.com</a>
RFID	<a href="http://www.ti-rfid.com">www.ti-rfid.com</a>
OMAP Mobile Processors	<a href="http://www.ti.com/omap">www.ti.com/omap</a>
Wireless Connectivity	<a href="http://www.ti.com/wirelessconnectivity">www.ti.com/wirelessconnectivity</a>

### Applications

Automotive and Transportation	<a href="http://www.ti.com/automotive">www.ti.com/automotive</a>
Communications and Telecom	<a href="http://www.ti.com/communications">www.ti.com/communications</a>
Computers and Peripherals	<a href="http://www.ti.com/computers">www.ti.com/computers</a>
Consumer Electronics	<a href="http://www.ti.com/consumer-apps">www.ti.com/consumer-apps</a>
Energy and Lighting	<a href="http://www.ti.com/energy">www.ti.com/energy</a>
Industrial	<a href="http://www.ti.com/industrial">www.ti.com/industrial</a>
Medical	<a href="http://www.ti.com/medical">www.ti.com/medical</a>
Security	<a href="http://www.ti.com/security">www.ti.com/security</a>
Space, Avionics and Defense	<a href="http://www.ti.com/space-avionics-defense">www.ti.com/space-avionics-defense</a>
Video and Imaging	<a href="http://www.ti.com/video">www.ti.com/video</a>

TI E2E Community Home Page

[e2e.ti.com](http://e2e.ti.com)

Mailing Address: Texas Instruments, Post Office Box 655303, Dallas, Texas 75265  
Copyright © 2012, Texas Instruments Incorporated