

43650			
CKTS	A	B	C
2	.380 9.65	.118 3.00	NA
3	.498 12.65	.236 6.00	NA
4	.616 15.65	.354 9.00	.185 4.70
5	.734 18.64	.472 12.00	.303 7.70
6	.852 21.64	.591 15.00	.421 10.70
7	.970 24.64	.709 18.00	.539 13.70
8	1.088 27.64	.827 21.00	.657 16.70
9	1.206 30.63	.945 24.00	.776 19.70
10	1.325 33.66	1.063 27.00	.894 22.70
11	1.443 36.65	1.181 30.00	1.012 25.70
12	1.561 39.65	1.299 33.00	1.130 28.70

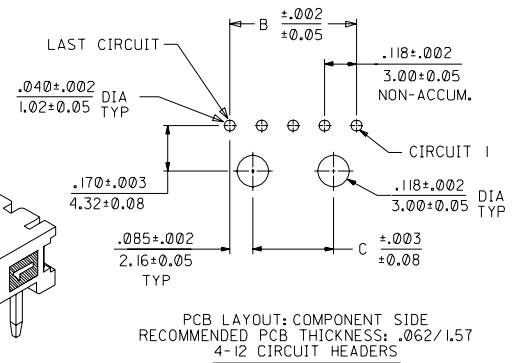

PCB LAYOUT: COMPONENT SIDE
RECOMMENDED PCB THICKNESS: .062/1.57
4-12 CIRCUIT HEADERS

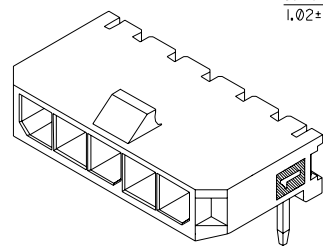
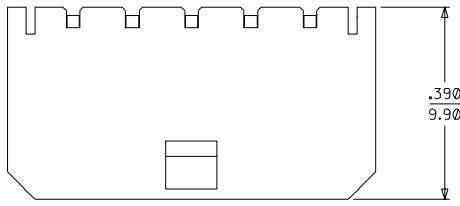
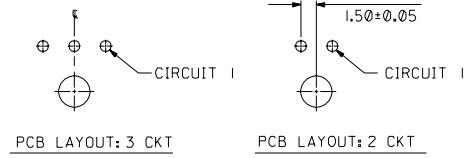
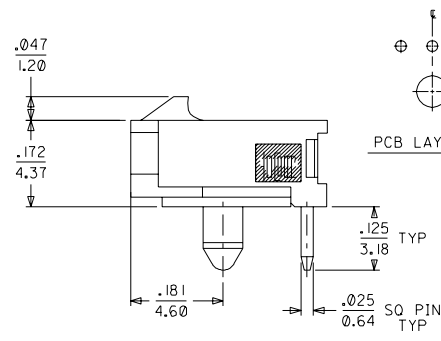
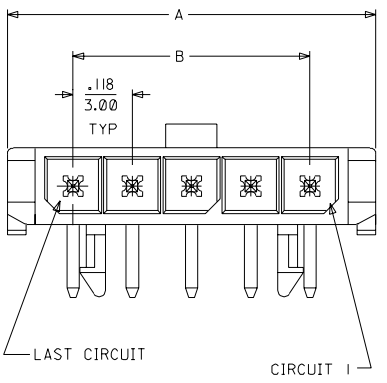

RECEPTACLE #43645

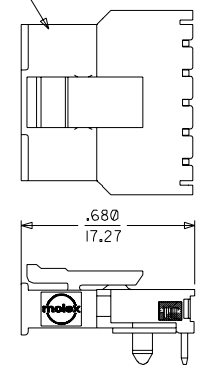

MATED MICRO FIT CONNECTOR

	FINISH A	FINISH B	FINISH C
CKTS	MATERIAL NO:	MATERIAL NO:	MATERIAL NO:
02	43650-0200	43650-0201	43650-0202
03	43650-0300	43650-0301	43650-0302
04	43650-0400	43650-0401	43650-0402
05	43650-0500	43650-0501	43650-0502
06	43650-0600	43650-0601	43650-0602
07	43650-0700	43650-0701	43650-0702
08	43650-0800	43650-0801	43650-0802
09	43650-0900	43650-0901	43650-0902
10	43650-1000	43650-1001	43650-1002
11	43650-1100	43650-1101	43650-1102
12	43650-1200	43650-1201	43650-1202

NT PLATE WAS 30U EC NO. UCR2001-0898 DRW: BURLINSON 01/04/02 CHK: MUELLER 01/04/02 APPR: EDGLEY 01/04/02	QUALITY SYMBOLS MAJOR $\nabla=0$ CRITICAL $\nabla=0$	GENERAL TOLERANCES: (UNLESS SPECIFIED) 4 PLACES ±0.10 3 PLACES ±0.15 2 PLACES ±0.25 1 PLACE ±0.36 ANGULAR: ±1/2°		SCALE: <input type="checkbox"/> mm <input type="checkbox"/> INCH	DESIGN UNITS: <input checked="" type="checkbox"/> mm <input type="checkbox"/> INCH	THIRD ANGLE PROJECTION: <input checked="" type="checkbox"/> THIRD ANGLE <input type="checkbox"/> FIRST ANGLE	DIMENSIONS: <input type="checkbox"/> mm <input type="checkbox"/> INCH <input type="checkbox"/> ONLY	SHT: <input type="checkbox"/> REV: <input type="checkbox"/>
		DRAWN BY & DATE: SAMIEC 00/07/07 CHECKED BY & DATE: MUELLER 00/07/07 APPROVED BY & DATE: EDGLEY 00/07/07 CAD FILENAME:	TITLE: MICRO FIT (3.0) SINGLE ROW / RIGHT ANGLE THRU HOLE / PEGS / TRAY	MATERIAL NO. MOLEX DRAWING NO. SD-43650-001	SHEET NO. 1 OF 1 SIZE C			

NOTES:

- HOUSING MATERIAL: LIQUID CRYSTAL POLYMER, GLASS FILLED, UL94V-0, COLOR - BLACK
TERMINAL MATERIAL: BRASS ALLOY
- FINISH:
 - A = .000100/(0.0025) MIN TIN/LEAD (90/10) OVER .000050/(0.0013) NICKEL PLATE.
 - B = .000015/(0.00038) MIN GOLD IN SELECTIVE AREA; .000050/(0.0013) MIN TIN/LEAD (90/10) ON SOLDER TAILS BOTH OVER .000050/(0.0013) NICKEL PLATE.
 - C = .000030/(0.00076) MIN GOLD IN SELECTIVE AREA; .000050/(0.0013) MIN TIN/LEAD (90/10) ON SOLDER TAILS BOTH OVER .000050/(0.0013) NICKEL PLATE.
- PRODUCT SPECIFICATION: PS-43650
- MATES WITH MICRO FIT (3.0) RECEPTACLE SERIES 43645
- TRAY PACKAGED : SEE MOLEX DRAWING PK-70873-0321