

TYPE 2020 INFRA-RED ILLUMINATOR

Description The type 2020 range of infra-red illuminators have been designed to offer a cost effective solution to night surveillance, with either 300W or 500W output in a stylish pressure die cast enclosure. These units provide a source of illumination for cameras with spectral response that extends into the infra-red region. To simplify operation and installation each illuminator is supplied with a built-in 25 lux light detector unit. These light-weight weatherproof assemblies have protective coated toughened glass filters and choice of sealed beam bulb. Replacement bulbs can be fitted in seconds. Full installation and maintenance instructions are provided with each unit.



Build Options:

2020/300N = 300Watt spot beam
2020/300M = 300 Watt medium beam
2020/300W = 300Watt wide beam
2020/500N = 500 Watt spot beam
2020/500M = 500 Watt medium beam
/SG = Stone guard
/CL = White light version

Key features:

- Optional 715nm or 830nm glass filter
- Bulb life: 2020/300-2000hrs,
2020/500-4000hrs
- Mountings for infra-red illuminators are available on type 428 and type 642 brackets
- Available in a range of beam angles
- Built-in 25 lux light detector on adjustable mounting
- Weatherproof to BS.EN 60529 Level IP 66

Dennard

FOR FURTHER INFORMATION or TO ORDER call +44(0)1252 614884
or go to..www.dennard-cctv.com or email: sales@dennard-cctv.com

5



TYPE 2020 INFRA-RED ILLUMINATOR

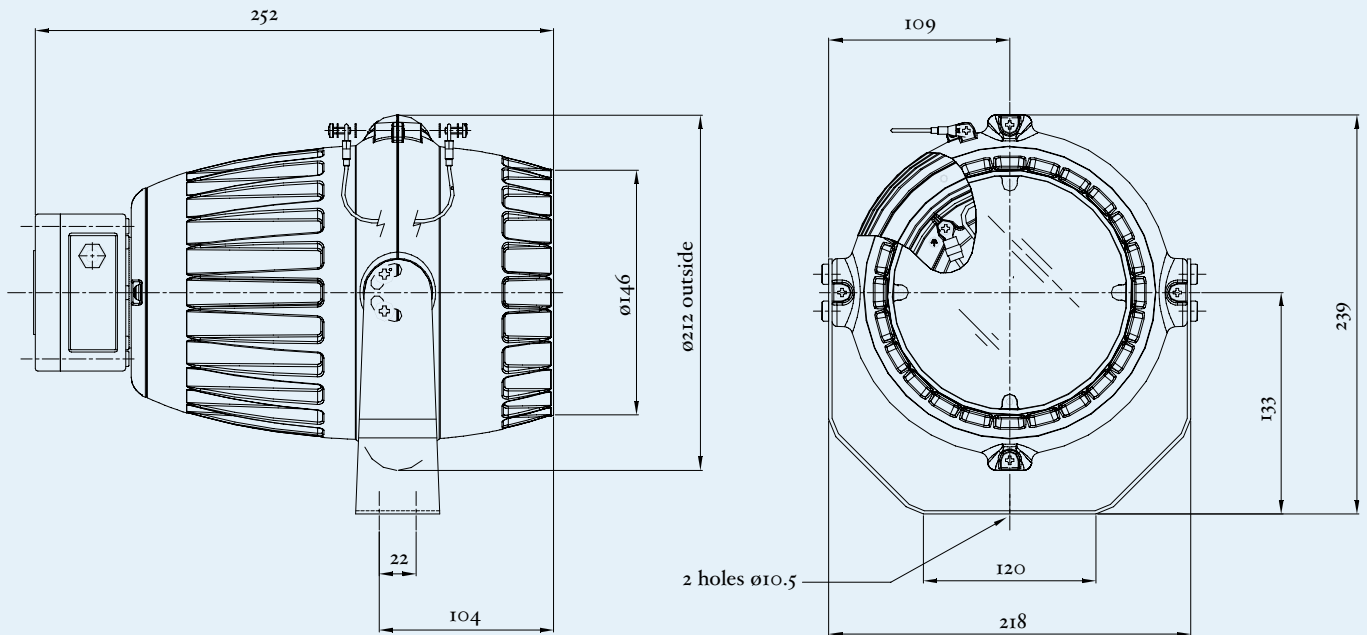

ALL DIMENSIONS IN mm

SPECIFICATION

	Type 2020/ 300W	Type 2020/ 300M	Type 2020/ 300N	Type 2020/ 500M	Type 2020/ 500N
Lamp	230Volt 300Watt Par56			230Volt 500Watt special Par56	
Weight	3kg			3kg	
Filters	Toughened glass 3mm thick			Toughened glass 3mm thick	
Transmission	Better than 90%			Better than 90%	
illumination 50 metres	2 lux	9 lux	16 lux	6 lux	48 lux
illumination 100 metres	-	1.75 lux	4 lux	1.5 lux	12 lux
illumination 200 metres	-	-	1 lux	0.4 lux	3 lux
Beam angles	horizontal - 60° vertical - 30°	horizontal - 30° vertical - 20°	horizontal - 20° vertical - 15°	horizontal - 39° vertical - 23°	horizontal - 11° vertical - 9°



Dennard Ltd 55 Fleet Road Fleet Hants GU51 3PN



T. +44(0)1252 614884 F. +44(0)1252 626013 email: sales@dennard-cctv.com

The information contained in this document is for guidance only. Specification and availability of the goods are subject to change without notice.