

## AD7811/AD7812

### FEATURES

- 10-Bit ADC with 2.3  $\mu$ s Conversion Time
- The AD7811 has Four Single-Ended Inputs that Can Be Configured as Three Pseudo Differential Inputs With Respect to a Common, or as Two Independent Pseudo Differential Channels
- The AD7812 has Eight Single-Ended Inputs that Can Be Configured as Seven Pseudo Differential Inputs with Respect to a Common, or as Four Independent Pseudo Differential Channels
- Onboard Track and Hold
- Onboard Reference 2.5 V  $\pm$  2.5%
- Operating Supply Range: 2.7 V to 5.5 V
- Specifications at 2.7 V–3.6 V and 5 V  $\pm$  10%
- DSP/Microcontroller Compatible Serial Interface
- High Speed Sampling and Automatic Power-Down Modes
- Package Address Pin on the AD7811 and AD7812 Allow Sharing of the Serial Bus in Multipackage Applications
- Input Signal Range: 0 V to  $V_{REF}$
- Reference Input Range: 1.2 V to  $V_{DD}$

### GENERAL DESCRIPTION

The AD7811 and AD7812 are high speed, low power, 10-bit A/D converters that operate from a single 2.7 V to 5.5 V supply. The devices contain a 2.3  $\mu$ s successive approximation A/D converter, an on-chip track/hold amplifier, a 2.5 V on-chip reference and a high speed serial interface that is compatible with the serial interfaces of most DSPs (Digital Signal Processors) and microcontrollers. The user also has the option of using an external reference by connecting it to the  $V_{REF}$  pin and setting the EXTREF bit in the control register. The  $V_{REF}$  pin may be tied to  $V_{DD}$ . At slower throughput rates the power-down mode may be used to automatically power down between conversions.

The control registers of the AD7811 and AD7812 allow the input channels to be configured as single-ended or pseudo differential. The control register also features a software convert start and a software power-down. Two of these devices can share the same serial bus and may be individually addressed in a multipackage application by hardwiring the device address pin. The AD7811 is available in a small, 16-lead 0.3" wide, plastic dual-in-line package (mini-DIP), in a 16-lead 0.15" wide, small outline IC (SOIC) and in a 16-lead, Thin Shrink Small Outline Package (TSSOP). The AD7812 is available in a small, 20-lead 0.3" wide, plastic dual-in-line package (mini-DIP), in a 20-lead, small outline IC (SOIC) and in a 20-lead, Thin Shrink Small Outline Package (TSSOP).

### PRODUCT HIGHLIGHTS

1. Low Power, Single Supply Operation  
Both the AD7811 and AD7812 operate from a single +2.7 V to +5.5 V supply and typically consume only 10 mW of power. The power dissipation can be significantly reduced at lower throughput rates by using the automatic power-down mode e.g., 315  $\mu$ W @ 10 kSPS,  $V_{DD} = 3$  V—see Power vs. Throughput.
2. 4-/8-Channel, 10-Bit ADC  
The AD7811 and AD7812 have four and eight single-ended input channels respectively. These inputs can be configured as pseudo differential inputs by using the Control Register.
3. On-chip 2.5 V ( $\pm$ 2.5%) reference circuit that is powered down when using an external reference.
4. Hardware and Software Control  
The AD7811 and AD7812 provide for both hardware and software control of Convert Start and Power-Down.

### FUNCTIONAL BLOCK DIAGRAMS

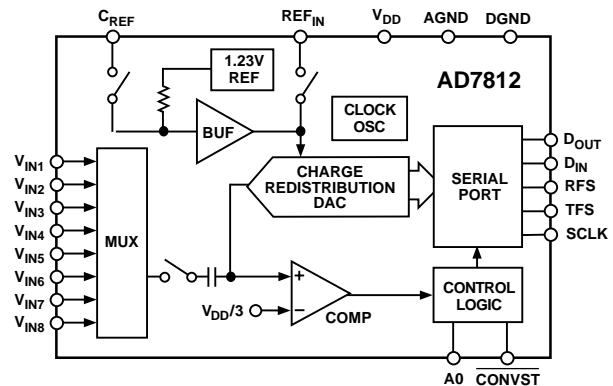
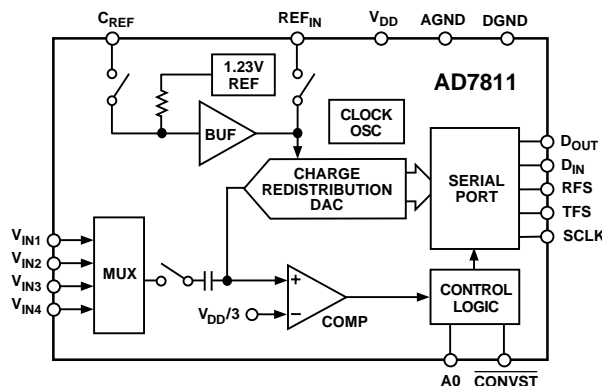

REV. 0

Information furnished by Analog Devices is believed to be accurate and reliable. However, no responsibility is assumed by Analog Devices for its use, nor for any infringements of patents or other rights of third parties which may result from its use. No license is granted by implication or otherwise under any patent or patent rights of Analog Devices.

# AD7811/AD7812—SPECIFICATIONS

Parameter	Y Version	Units	Test Conditions/Comments
<b>DYNAMIC PERFORMANCE</b>			
Signal to (Noise + Distortion) Ratio <sup>1</sup>	58	dB min	$f_{IN} = 30$ kHz Any Channel, $f_{SAMPLE} = 350$ kHz $V_{REF}$ Internal or External
Total Harmonic Distortion (THD) <sup>1</sup>	-66	dB max	
Peak Harmonic or Spurious Noise <sup>1</sup>	-80	dB typ	
Intermodulation Distortion <sup>1, 2</sup>			$f_a = 29$ kHz, $f_b = 30$ kHz
Second Order Terms	-67	dB max	
Third Order Terms	-67	dB max	
Channel-to-Channel Isolation <sup>1, 2</sup>	-80	dB typ	$f_{IN} = 20$ kHz
<b>DC ACCURACY</b>			
Resolution	10	Bits	Any Channel

Parameter	Y Version	Units	Test Conditions/Comments
POWER SUPPLY			
$V_{DD}$	2.7	V min	For Specified Performance
	5.5	V max	
$I_{DD}$			Digital Inputs = 0 V or $V_{DD}$
Normal Operation	3.5	mA max	
Power-Down			
Full Power-Down	1	$\mu$ A max	
Partial Power-Down (Internal Ref)	350	$\mu$ A max	See Power-Up Times Section
Power Dissipation			$V_{DD} = 3$ V
Normal Operation	10.5	mW max	
Auto Full Power-Down			See Power vs. Throughput Section
Throughput 1 kSPS	31.5	$\mu$ W max	
Throughput 10 kSPS	315	$\mu$ W max	
Throughput 100 kSPS	3.15	mW max	
Partial Power-Down (Internal Ref)	1.05	mW max	
Full Power-Down	3	$\mu$ W max	

## NOTES

<sup>1</sup>See Terminology.<sup>2</sup>Sample tested during initial release and after any redesign or process change that may affect this parameter.

Specifications subject to change without notice.

TIMING CHARACTERISTICS<sup>1, 2</sup> ( $V_{DD} = 2.7$  V to 5.5 V,  $V_{REF} = +V_{DD}$  [EXT] unless otherwise noted)

Parameter	Y Version	Units	Conditions/Comments
$t_{POWER-UP}$	1	$\mu$ s (max)	Power-Up Time of AD7811/AD7812 After Rising Edge of $\overline{CONVST}$
$t_1$	2.3	$\mu$ s (max)	Conversion Time
$t_2$	20	ns (min)	$\overline{CONVST}$ Pulse Width
$t_3$	25	ns (min)	SCLK High Pulse Width
$t_4$	25	ns (min)	SCLK Low Pulse Width
$t_{5^3}$	5	ns (min)	RFS Rising Edge to SCLK Rising Edge Setup Time
$t_{6^3}$	5	ns (min)	TFS Falling Edge to SCLK Falling Edge Setup Time
$t_7^3$	10	ns (max)	SCLK Rising Edge to Data Out Valid
$t_8$	10	ns (min)	$D_{IN}$ Data Valid to SCLK Falling Edge Setup Time
$t_9$	5	ns (min)	$D_{IN}$ Data Valid after SCLK Falling Edge Hold Time
$t_{10^3, 4}$	20	ns (max)	SCLK Rising Edge to $D_{OUT}$ High Impedance
$t_{11}$	100	ns (min)	$D_{OUT}$ High Impedance to $\overline{CONVST}$ Falling Edge

## NOTES

<sup>1</sup>Sample tested to ensure compliance.<sup>2</sup>See Figures 16, 17 and 18.<sup>3</sup>These numbers are measured with the load circuit of Figure 1. They are defined as the time required for the o/p to cross 0.8 V or 2.4 V for  $V_{DD} = 5$  V  $\pm$  10% and 0.4 V or 2 V for  $V_{DD} = 3$  V  $\pm$  10%.<sup>4</sup>Derived from the measured time taken by the data outputs to change 0.5 V when loaded with the circuit of Figure 1. The measured number is then extrapolated back to remove the effects of charging or discharging the 50 pF capacitor. This means that the time,  $t_{11}$ , quoted in the Timing Characteristics is the true bus relinquish time of the part and as such is independent of external bus loading capacitances.

Figure 1. Load Circuit for Digital Output Timing Specifications

# AD7811/AD7812

## ABSOLUTE MAXIMUM RATINGS\*

$V_{DD}$  to DGND ..... -0.3 V to +7 V  
 Digital Input Voltage to DGND ( $\overline{\text{CONVST}}$ , SCLK, RFS, TFS,  $D_{IN}$ , A0) ..... -0.3 V,  $V_{DD} + 0.3$  V  
 Digital Output Voltage to DGND ( $D_{OUT}$ ) ..... -0.3 V,  $V_{DD} + 0.3$  V  
 $REF_{IN}$  to AGND ..... -0.3 V,  $V_{DD} + 0.3$  V  
**Analog Inputs**  
 $V_{IN1}-V_{IN4}$  (AD7811) ..... -0.3 V,  $V_{DD} + 0.3$  V  
 $V_{IN1}-V_{IN8}$  (AD7812) ..... -0.3 V,  $V_{DD} + 0.3$  V  
 Storage Temperature Range ..... -65°C to +150°C  
 Junction Temperature ..... +150°C  
 Plastic DIP Package, Power Dissipation ..... 450 mW  
 $\theta_{JA}$  Thermal Impedance ..... +105°C/W  
 Lead Temperature, (Soldering 10 secs) ..... +260°C

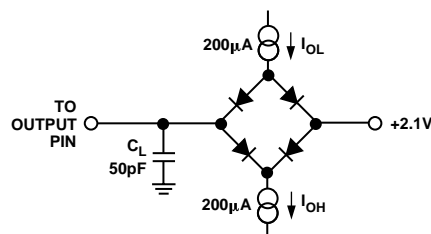
SOIC Package, Power Dissipation ..... 450 mW  
 $\theta_{JA}$  Thermal Impedance ..... 75°C/W  
 Lead Temperature, Soldering

## ORDERING GUIDE

Model	Linearity Error	Package Description	Package Options
AD7811YN	±1 LSB	16-Lead Plastic DIP	N-16
AD7811YR	±1 LSB	16-Lead Small Outline IC (SOIC)	R-16A
AD7811YRU	±1 LSB	16-Lead Thin Shrink Small Outline Package (TSSOP)	RU-16
AD7812YN	±1 LSB	20-Lead Plastic DIP	N-20
AD7812YR	±1 LSB	20-Lead Small Outline IC (SOIC)	R-20A
AD7812YRU	±1 LSB	20-Lead Thin Shrink Small Outline Package (TSSOP)	RU-20

## PIN CONFIGURATIONS

## DIP/SOIC/TSSOP

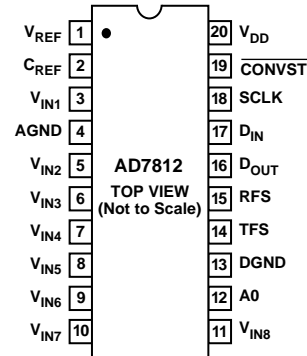
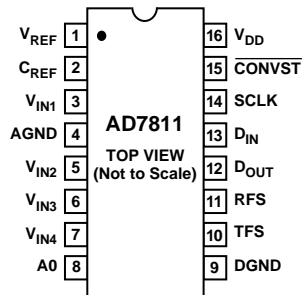

## PIN FUNCTION DESCRIPTIONS

Pin(s) AD7811	Pin(s) AD7812	Name	Description
1	1	$V_{REF}$	An external reference input can be applied here. When using an external precision reference or $V_{DD}$ the EXTREF bit in the control register must be set to logic one. The external reference input range is 1.2 V to $V_{DD}$ .
2	2	$C_{REF}$	Reference Capacitor. A capacitor (10 nF) is connected here to improve the noise performance of the on-chip reference.
3, 5–7	3, 5–11	$V_{IN1}$ – $V_{IN4(8)}$	Analog Inputs. The analog input range is 0 V to $V_{REF}$ .
4	4	AGND	Analog Ground. Ground reference for track/hold, comparator, on-chip reference and DAC.
8	12	A0	Package Address Pin. This Logic Input can be hardwired high or low. When used in conjunction with the package address bit in the control register this input allows two devices to share the same serial bus. For example a twelve channel solution can be achieved by using the AD7811 and the AD7812 on the same serial bus.
9	13	DGND	Digital Ground. Ground reference for digital circuitry.
10	14	TFS	Transmit Frame Sync. The falling edge of this Logic Input tells the part that a new control byte should be shifted in on the next 10 falling edges of SCLK.
11	15	RFS	Receive Frame Sync. The rising edge of this Logic Input is used to enable a counter in the serial interface. It is used to provide compatibility with DSPs which use a continuous serial clock and framing signal. It can also be used as a CS (Chip Select) pin in multipackage applications. The serial interface will ignore the SCLK until it receives a rising edge on this input. The counter is reset at the end of a serial read operation.
12	16	$D_{OUT}$	Serial Data Output. Serial data is shifted out on this pin on the rising edge of the serial clock. The output enters a High impedance condition on the rising edge of the 11th SCLK pulse.
13	17	$D_{IN}$	Serial Data Input. The control byte is read in at this input. In order to complete a serial write operation 13 SCLK pulses need to be provided. Only the first 10 bits are shifted in—see Serial Interface section.
14	18	SCLK	Serial Clock Input. An external serial clock is applied to this input to obtain serial data from the AD7811/AD7812 and also to latch data into the AD7811/AD7812. Data is clocked out on the rising edge of SCLK and latched in on the falling edge of SCLK.
15	19	$\overline{\text{CONVST}}$	Convert Start. This is an edge triggered logic input. The Track/Hold goes into its Hold Mode on the falling edge of this signal and a conversion is initiated. The state of this pin at the end of conversion also determines whether the part is powered down or not. See operating modes section of this data sheet.
16	20	$V_{DD}$	Positive Supply Voltage +2.7 V to +5.5 V.

# AD7811/AD7812

## TERMINOLOGY

### Signal to (Noise + Distortion) Ratio

This is the measured ratio of signal to (noise + distortion) at the output of the A/D converter. The signal is the rms amplitude of the fundamental. Noise is the rms sum of all nonfundamental signals up to half the sampling frequency ( $f_s/2$ ), excluding dc. The ratio is dependent upon the number of quantization levels in the digitization process; the more levels, the smaller the quantization noise. The theoretical signal to (noise + distortion) ratio for an ideal N-bit converter with a sine wave input is given by:

$$\text{Signal to (Noise + Distortion)} = (6.02N + 1.76) \text{ dB}$$

Thus for a 10-bit converter, this is 62 dB.

### Total Harmonic Distortion

Total harmonic distortion (THD) is the ratio of the rms sum of harmonics to the fundamental. For the AD7811 and AD7812 it is defined as:

$$\text{THD (dB)} = 20 \log \frac{\sqrt{V_2^2 + V_3^2 + V_4^2 + V_5^2 + V_6^2}}{V_1}$$

where  $V_1$  is the rms amplitude of the fundamental and  $V_2$ ,  $V_3$ ,  $V_4$ ,  $V_5$  and  $V_6$  are the rms amplitudes of the second through the sixth harmonics.

### Peak Harmonic or Spurious Noise

Peak harmonic or spurious noise is defined as the ratio of the rms value of the next largest component in the ADC output spectrum (up to  $f_s/2$  and excluding dc) to the rms value of the fundamental. Normally, the value of this specification is determined by the largest harmonic in the spectrum, but for parts where the harmonics are buried in the noise floor, it will be a noise peak.

### Intermodulation Distortion

With inputs consisting of sine waves at two frequencies,  $f_a$  and  $f_b$ , any active device with nonlinearities will create distortion products at sum and difference frequencies of  $m f_a \pm n f_b$  where  $m, n = 0, 1, 2, 3$ , etc. Intermodulation terms are those for which neither  $m$  nor  $n$  are equal to zero. For example, the second order terms include  $(f_a + f_b)$  and  $(f_a - f_b)$ , while the third order terms include  $(2f_a + f_b)$ ,  $(2f_a - f_b)$ ,  $(f_a + 2f_b)$  and  $(f_a - 2f_b)$ .

The AD7811 and AD7812 are tested using the CCIF standard where two input frequencies near the top end of the input bandwidth are used. In this case, the second and third order terms are of different significance. The second order terms are

usually distanced in frequency from the original sine waves while the third order terms are usually at a frequency close to the input frequencies. As a result, the second and third order terms are specified separately. The calculation of the intermodulation distortion is as per the THD specification where it is the ratio of the rms sum of the individual distortion products to the rms amplitude of the fundamental expressed in dBs.

### Channel-to-Channel Isolation

Channel-to-channel isolation is a measure of the level of crosstalk between channels. It is measured by applying a full-scale 20 kHz sine wave signal to all nonselected input channels and determining how much that signal is attenuated in the selected channel. The figure given is the worst case across all four or eight channels for the AD7811 and AD7812 respectively.

### Relative Accuracy

Relative accuracy, or endpoint nonlinearity, is the maximum deviation from a straight line passing through the endpoints of the ADC transfer function.

### Differential Nonlinearity

This is the difference between the measured and the ideal 1 LSB change between any two adjacent codes in the ADC.

### Offset Error

This is the deviation of the first code transition (0000 . . . 000) to (0000 . . . 001) from the ideal, i.e.,  $AGND + 1 \text{ LSB}$ .

### Offset Error Match

This is the difference in Offset Error between any two channels.

### Gain Error

This is the deviation of the last code transition (1111 . . . 110) to (1111 . . . 111) from the ideal, i.e.,  $V_{REF} - 1 \text{ LSB}$ , after the offset error has been adjusted out.

### Gain Error Match

This is the difference in Gain Error between any two channels.

### Track/Hold Acquisition Time

Track/hold acquisition time is the time required for the output of the track/hold amplifier to reach its final value, within  $\pm 1/2 \text{ LSB}$ , after the end of conversion (the point at which the track/hold returns to track mode). It also applies to situations where a change in the selected input channel takes place or where there is a step input change on the input voltage applied to the selected  $V_{IN}$  input of the AD7811 or AD7812. It means that the user must wait for the duration of the track/hold acquisition time after the end of conversion or after a channel change/step input change to  $V_{IN}$  before starting another conversion, to ensure that the part operates to specification.

**Control Register (AD7811)**

The Control Register is a 10-bit-wide, write only register. The Control Register is written to when the AD7811 receives a falling edge on its TFS pin. The AD7811 will maintain the same configuration until a new control byte is written to the part. The control register can be written to at the same time data is being read. This latter feature enhances throughput rates when software control is being used or when the analog input channels are being changed frequently. The power-up default register contents are all zeros; therefore, when the supplies are connected, the AD7811 is powered down by default.

**Control Register AD7811**

9	X*	A0	PD1	PD0	$V_{IN4}/\overline{AGND}$	DIFF/SGL	CH1	CH0	$\overline{CONVST}$	EXTREF	0
---	----	----	-----	-----	---------------------------	----------	-----	-----	---------------------	--------	---

\*This is a don't care bit.

**A0** This is the package address bit. It is used in conjunction with the package address pin to allow two AD7811s to share the same serial bus. The AD7811 can also share the same serial bus with the AD7812. When a control word is written to the control register of the AD7811 the control word is ignored if the package address bit in the control byte does not match how the package address pin is hardwired. Only the serial port of the device that received the last valid control byte, i.e., the address bit matched the address pin, will attempt to drive the serial bus on the next serial read. When the part powers up this bit is set to 0.

**PD1, PD0** These bits allow the AD7811 to be fully powered down and powered up. Bit combinations PD1 = PD0 = 0 and PD1 = PD0 = 1 override the automatic power-down decision at the end of conversion. These bits also decide the power-down mode when the AD7811 enters a power-down at the end of a conversion. There are two power-down modes—Full Power-Down and Partial Power-Down. See Power-Down Options section of this data sheet.

PD1	PD0	Description
0	0	Full Power-Down of the AD7811
0	1	Partial Power-Down at the End of Conversion
1	0	Full Power-Down at the End of Conversion
1	1	Power-Up the AD7811

$V_{IN4}/\overline{AGND}$  The DIF/SGL bit in the control register must be set to 0 to use this option otherwise this bit is ignored. Setting  $V_{IN4}/\overline{AGND}$  to 0 configures the analog inputs of the AD7811 as four single-ended analog inputs referenced to analog ground (AGND). By setting this bit to 1 the input channels  $V_{IN1}$  to  $V_{IN3}$  are configured as three pseudo-differential channels with respect to  $V_{IN4}$ —see Table I.

**DIF/SGL** This bit is used to configure the analog inputs as single ended or pseudo differential pairs. By setting this bit to 0 the analog inputs can be configured as single ended with respect to AGND, or pseudo differential with respect to  $V_{IN4}$  as explained above. Setting this bit to 1 configures the analog input channels as two pseudo differential pairs  $V_{IN1}/V_{IN2}$  and  $V_{IN3}/V_{IN4}$ —see Table I.

**CH1, CH0** These bits are used in conjunction with  $V_{IN4}/\overline{AGND}$  and DIF/SGL to select an analog input channel. The table shows how the various channel selections are made—see Table I.

$\overline{CONVST}$  Setting this bit to a logic one initiates a conversion. A conversion is initiated 400 ns after a write to the control register has taken place. This allows a signal to be acquired even if the channel is changed and a conversion initiated in the same serial write. The bit is reset after the end of a conversion.

**EXTREF** This bit must be set to a logic one if the user wishes to use an external reference or use  $V_{DD}$  as the reference. When the external reference is selected the on chip reference circuitry powers down.

# AD7811/AD7812

## Control Register (AD7812)

The Control Register is a 10-bit-wide, write only register. The Control Register is written to when the AD7812 receives a falling edge on its TFS pin. The AD7812 will maintain the same configuration until a new control byte is written to the part. The control register can be written to at the same time data is being read. This latter feature enhances throughput rates when software control is being used or when the analog input channels are being changed frequently. The power-up default register contents are all zeros; therefore, when the supplies are connected, the AD7812 is powered down by default.

### Control Register AD7812

9									0
A0	PD1	PD0	$V_{IN8}/\overline{AGND}$	DIF/ $\overline{SGL}$	CH2	CH1	CH0	$\overline{CONVST}$	EXTREF

**A0** This is the package address bit. It is used in conjunction with the package address pin to allow two AD7812s to share the same serial bus. The AD7812 can also share the same serial bus with the AD7811. When a control word is written to the control register of the AD7812 the control word is ignored if the package address bit in the control byte does not match how the package address pin is hardwired. Only the serial port of the device which received the last valid control byte, i.e., the address bit matched the address pin, will attempt to drive the serial bus on the next serial read. When the part powers up this bit is set to 0.

**PD1, PD0** These bits allow the AD7812 to be fully powered down and powered up. Bit combinations PD1 = PD0 = 0 and PD1 = PD0 = 1 override the automatic power-down decision at the end of conversion. These bits also decide the power-down mode when the AD7812 enters a power-down at the end of a conversion. There are two power-down modes—Full Power-Down and Partial Power-Down. See Power-Down section of this data sheet.

PD1	PD0	Description
0	0	Full Power-Down of the AD7812
0	1	Partial Power-Down at the End of Conversion
1	0	Full Power-Down at the End of Conversion
1	1	Power-Up the AD7812

$V_{IN8}/\overline{AGND}$  The DIF/ $\overline{SGL}$  bit in the control register must be set to 0 in order to use this option otherwise this bit is ignored. Setting  $V_{IN8}/\overline{AGND}$  to 0 configures the analog inputs of the AD7812 as eight single-ended analog inputs referenced to analog ground (AGND). By setting this bit to 1 the input channels  $V_{IN1}$  to  $V_{IN7}$  are configured as seven pseudo differential channels with respect to  $V_{IN8}$ —see Table II.

**DIF/ $\overline{SGL}$**  This bit is used to configure the analog inputs as single ended or pseudo differential pairs. By setting this bit to 0 the analog inputs can be configured as single ended with respect to AGND, or pseudo differential with respect to  $V_{IN8}$  as explained above. Setting this bit to 1 configures the analog input channels as four pseudo differential pairs  $V_{IN1}/V_{IN2}$ ,  $V_{IN3}/V_{IN4}$ ,  $V_{IN5}/V_{IN6}$  and  $V_{IN7}/V_{IN8}$ —see Table II.

**CH2, CH1, CH0** These bits are used in conjunction with  $V_{IN8}/\overline{AGND}$  and DIF/ $\overline{SGL}$  to select an analog input channel. Table II shows how the various channel selections are made.

$\overline{CONVST}$  Setting this bit to a logic one initiates a conversion. A conversion is initiated 400 ns after a write to the control register has taken place. This allows a signal to be acquired even if the channel is changed and a conversion initiated in the same write operation. The bit is reset after the end of a conversion.

**EXTREF** This bit must be set to a logic one if the user wishes to use an external reference or use  $V_{DD}$  as the reference. When the external reference is selected the on-chip reference circuitry powers down and the current consumption is reduced by about 1 mA.



Table I. AD7811 Channel Configurations

$V_{IN4}/\overline{AGND}$	$DIF/\overline{SGL}$	CH1	CH0	Description
0	0	0	0	$V_{IN1}$ Single Ended with Respect to AGND
0	0	0	1	$V_{IN2}$ Single Ended with Respect to AGND
0	0	1	0	$V_{IN3}$ Single Ended with Respect to AGND
0	0	1	1	$V_{IN4}$ Single Ended with Respect to AGND
1	0	0	0	$V_{IN1}$ Pseudo Differential with Respect to $V_{IN4}$
1	0	0	1	$V_{IN2}$ Pseudo Differential with Respect to $V_{IN4}$
1	0	1	0	$V_{IN3}$ Pseudo Differential with Respect to $V_{IN4}$
X	1	0	0	$V_{IN1}(+)$ Pseudo Differential with Respect to $V_{IN2}(-)$
X	1	0	1	$V_{IN3}(+)$ Pseudo Differential with Respect to $V_{IN4}(-)$
X	1	1	0	Internal Test. SAR Input Equal to $V_{REF}/2$
X	1	1	1	Internal Test. SAR Input Equal to $V_{REF}$

Table II. AD7812 Channel Configurations

$V_{IN8}/\overline{AGND}$	$DIF/\overline{SGL}$	CH2	CH1	CH0	Description
0	0	0	0	0	$V_{IN1}$ Single Ended with Respect to AGND
0	0	0	0	1	$V_{IN2}$ Single Ended with Respect to AGND
0	0	0	1	0	$V_{IN3}$ Single Ended with Respect to AGND
0	0	0	1	1	$V_{IN4}$ Single Ended with Respect to AGND
0	0	1	0	0	$V_{IN5}$ Single Ended with Respect to AGND
0	0	1	0	1	$V_{IN6}$ Single Ended with Respect to AGND
0	0	1	1	0	$V_{IN7}$ Single Ended with Respect to AGND
0	0	1	1	1	$V_{IN8}$ Single Ended with Respect to AGND
1	0	0	0	0	$V_{IN1}$ Pseudo Differential with Respect to $V_{IN8}$
1	0	0	0	1	$V_{IN2}$ Pseudo Differential with Respect to $V_{IN8}$
1	0	0	1	0	$V_{IN3}$ Pseudo Differential with Respect to $V_{IN8}$
1	0	0	1	1	$V_{IN4}$ Pseudo Differential with Respect to $V_{IN8}$
1	0	1	0	0	$V_{IN5}$ Pseudo Differential with Respect to $V_{IN8}$
1	0	1	0	1	$V_{IN6}$ Pseudo Differential with Respect to $V_{IN8}$
1	0	1	1	0	$V_{IN7}$ Pseudo Differential with Respect to $V_{IN8}$
X	1	0	0	0	$V_{IN1}(+)$ Pseudo Differential with Respect to $V_{IN2}(-)$
X	1	0	0	1	$V_{IN3}(+)$ Pseudo Differential with Respect to $V_{IN4}(-)$
X	1	0	1	0	$V_{IN5}(+)$ Pseudo Differential with Respect to $V_{IN6}(-)$
X	1	0	1	1	$V_{IN7}(+)$ Pseudo Differential with Respect to $V_{IN8}(-)$
X	1	1	0	0	Internal Test. SAR Input Equal to $V_{REF}/2$
X	1	1	0	1	Internal Test. SAR Input Equal to $V_{REF}$

# AD7811/AD7812

## CIRCUIT DESCRIPTION

### Converter Operation

The AD7811 and AD7812 are successive approximation analog-to-digital converters based around a charge redistribution DAC. The ADCs can convert analog input signals in the range 0 V to  $V_{DD}$ . Figures 2 and 3 show simplified schematics of the ADC. Figure 2 shows the ADC during its acquisition phase. SW2 is closed and SW1 is in position A, the comparator is held in a balanced condition and the sampling capacitor acquires the signal on  $V_{IN}$ .

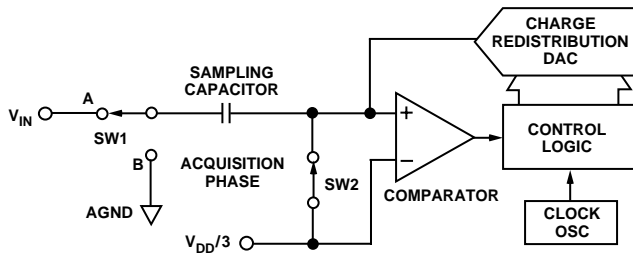
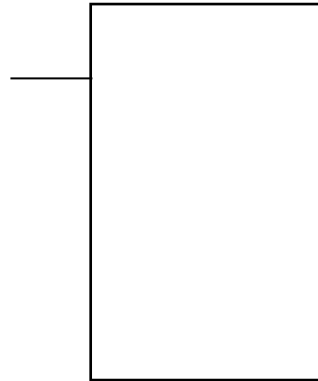

Figure 2. ADC Acquisition Phase

When the ADC starts a conversion, see Figure 3, SW2 will open and SW1 will move to position B causing the comparator to become unbalanced. The Control Logic and the Charge Redistribution DAC are used to add and subtract fixed amounts of charge from the sampling capacitor to bring the comparator back into a balanced condition. When the comparator is rebalanced, the conversion is complete. The Control Logic generates the ADC output code. Figure 10 shows the ADC transfer function.

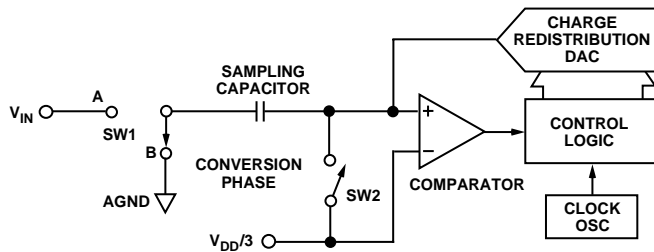

Figure 3. ADC Conversion Phase

### TYPICAL CONNECTION DIAGRAM

Figure 4 shows a typical connection diagram for the AD7811/AD7812. The AGND and DGND are connected together at the device for good noise suppression. The serial interface is implemented using three wires with RFS/TFS connected to CONVST see Serial Interface section for more details.  $V_{REF}$  is connected to a well decoupled  $V_{DD}$  pin to provide an analog input range of 0 V to  $V_{DD}$ . If the AD7811 or AD7812 is not sharing a serial bus with another AD7811 or AD7812 then A0 (package address pin) should be hardwired low. The default power up value of the package address bit in the control register is 0. For applications where power consumption is of concern, the automatic power down at the end of a conversion should be used to improve power performance. See Power-Down Options section of the data sheet.

An example of the pseudo differential scheme using the AD7811 is shown in Figure 6. The relevant bits in the AD7811 Control Register are set as follows  $DIF/\overline{SGL} = 1$ ,  $CH1 = CH2 = 0$ , i.e.,  $V_{IN1}$  pseudo differential with respect to  $V_{IN2}$ . The signal is applied to  $V_{IN1}$  but in the pseudo differential scheme the sampling capacitor is connected to  $V_{IN2}$  during conversion and not AGND as described in the Converter Operation section. This input scheme can be used to remove offsets that exist in a system. For example, if a system had an offset of 0.5 V the offset could be applied to  $V_{IN2}$  and the signal applied to  $V_{IN1}$ . This has the effect of offsetting the input span by 0.5 V. It is only possible to offset the input span when the reference voltage is less than  $V_{DD}-\text{OFFSET}$ .

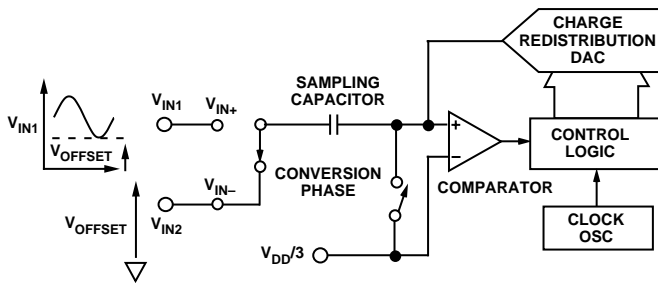

Figure 6. Pseudo Differential Input Scheme

When using the pseudo differential input scheme the signal on  $V_{IN2}$  must not vary by more than a 1/2 LSB during the conversion process. If the signal on  $V_{IN2}$  varies during conversion, the conversion result will be incorrect. In single-ended mode the sampling capacitor is always connected to AGND during conversion. Figure 7 shows the AD7811/AD7812 pseudo differential input being used to make a unipolar dc current measurement. A sense resistor is used to convert the current to a voltage and the voltage is applied to the differential input as shown.

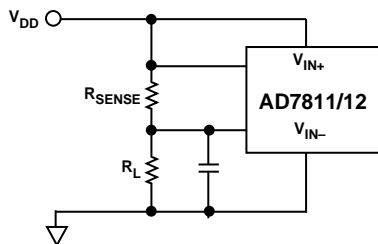

Figure 7. DC Current Measurement Scheme

### DC Acquisition Time

The ADC starts a new acquisition phase at the end of a conversion and ends on the falling edge of the  $\overline{\text{CONVST}}$  signal. At the end of a conversion a settling time is associated with the sampling circuit. This settling time lasts approximately 100 ns. The analog signal on  $V_{IN+}$  is also being acquired during this settling time. Therefore, the minimum acquisition time needed is approximately 100 ns.

Figure 8 shows the equivalent charging circuit for the sampling capacitor when the ADC is in its acquisition phase.  $R2$  represents the source impedance of a buffer amplifier or resistive network;  $R1$  is an internal multiplexer resistance, and  $C1$  is the sampling capacitor. During the acquisition phase the sampling capacitor must be charged to within a 1/2 LSB of its final value. The time it takes to charge the sampling capacitor ( $T_{\text{CHARGE}}$ ) is given by the following formula:

$$T_{\text{CHARGE}} = 7.6 \times (R2 + 125 \Omega) \times 3.5 \text{ pF}$$

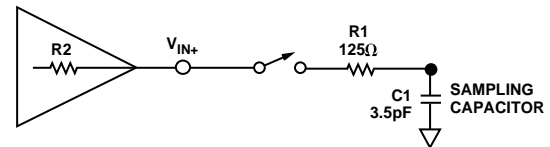

Figure 8. Equivalent Sampling Circuit

For small values of source impedance, the settling time associated with the sampling circuit (100 ns) is, in effect, the acquisition time of the ADC. For example, with a source impedance ( $R2$ ) of 10  $\Omega$  the charge time for the sampling capacitor is approximately 4 ns. The charge time becomes significant for source impedances of 2 k $\Omega$  and greater.

### AC Acquisition Time

In ac applications it is recommended to always buffer analog input signals. The source impedance of the drive circuitry must be kept as low as possible to minimize the acquisition time of the ADC. Large values of source impedance will cause the THD to degrade at high throughput rates. In addition, better performance can generally be achieved by using an External 1 nF capacitor on  $V_{IN}$ .

### ON-CHIP REFERENCE

The AD7811 and AD7812 have an on-chip 2.5 V reference circuit. The schematic in Figure 9 shows how the reference circuit is implemented. A 1.23 V bandgap reference is gained up to provide a 2.5 V  $\pm$  2% reference voltage. The on-chip reference is not available externally (SW2 is open). An external reference (1.2 V to  $V_{DD}$ ) can be applied at the  $V_{\text{REF}}$  pin. However in order to use an external reference the EXTREF bit in the control register (Bit 0) must first be set to a logic 1. When EXTREF is set to a Logic 1 SW2 will close, SW3 will open and the amplifier will power down. This will reduce the current consumption of the part by about 1 mA. It is possible to use two different reference voltages by selecting the on-chip reference or external reference.

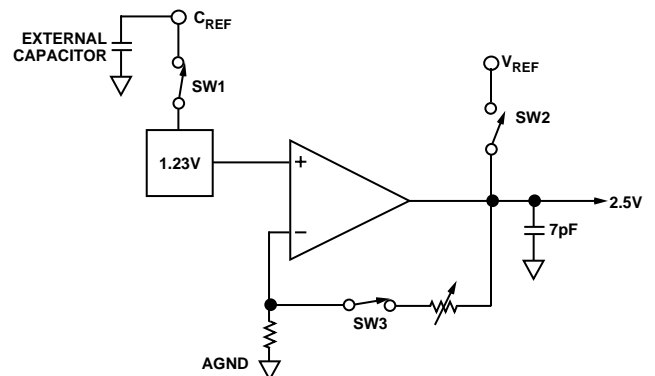

Figure 9. On-Chip Reference Circuitry

# AD7811/AD7812

When using automatic power-down between conversions to improve the power performance of the part (see Power vs. Throughput) the switch SW1 will open when the part enters its power-down mode if using the internal on-chip reference. This provides a high impedance discharge path for the external capacitor (see Figure 9). A typical value of external capacitance is 10 nF. When the part is in Mode 2 Full Power-Down, because the external capacitor holds its charge during power-down, the internal bandgap reference will power up more quickly after relatively short periods of full power-down. When operating the part in Mode 2 Partial Power-Down the external capacitor is not required as the on-chip reference stays powered up while the rest of the circuitry powers down.

## ADC TRANSFER FUNCTION

The output coding of the AD7811 and AD7812 is straight binary. The designed code transitions occur at successive integer LSB values (i.e., 1 LSB, 2 LSBs, etc.). The LSB size is  $= V_{REF}/1024$ . The ideal transfer characteristic for the AD7811 and AD7812 is shown in Figure 10.

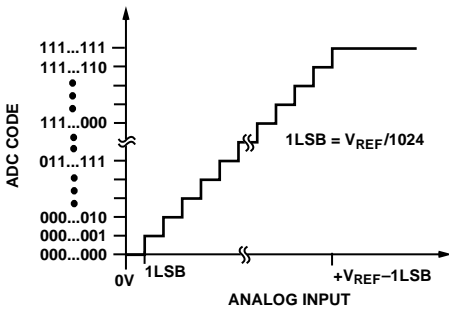

Figure 10. AD7811 and AD7812 Transfer Characteristic

## POWER-DOWN OPTIONS

The AD7811 and AD7812 provide flexible power management to allow the user to achieve the best power performance for a given throughput rate.

The power management options are selected by programming the power-down bits (i.e., PD1 and PD0) in the control register. Table III below summarizes the options available. When the power-down bits are programmed for Mode 2 Power Down (full and partial), a rising edge on the  $\overline{\text{CONVST}}$  pin will power up the part. This feature is used when powering down between conversions—see Power vs. Throughput. When the AD7811 and AD7812 are placed in partial power-down the on-chip reference does not power down. However, the part will power up more quickly after long periods of power-down when using partial power-down—see Power-Up Times section.

Table III. AD7811/AD7812 Power-Down Options

PD1	PD0	$\overline{\text{CONVST}}^*$	Description
1	1	x	Full Power-Up
0	0	x	Full Power-Down
0	1	0	Mode 2 Partial Power-Down (Reference Stays Powered-Up)
0	1	1	No Power-Down
1	0	0	Mode 2 Full Power-Down
1	0	1	No Power-Down

\*This refers to the state of the  $\overline{\text{CONVST}}$  signal at the end of a conversion.

## POWER-UP TIMES

The AD7811 and AD7812 have a 1  $\mu\text{s}$  power-up time when using an external reference or when powering up from partial power-down. When  $V_{DD}$  is first connected, the AD7811 and AD7812 are in a low current mode of operation. In order to carry out a conversion the AD7811 and AD7812 must first be powered up by writing to the control register of each ADC to set the power-down bits (i.e., PD1 = 1, PD0 = 1) for a full power-up. See the Quick Evaluation Setup on the following page.

### Mode 2 Full Power-Down (PD1 = 1, PD0 = 0)

The power-up time of the AD7811 and AD7812 after power is first connected, or after a long period of Full Power-Down, is the time it takes the on-chip 1.23 V reference to power up plus the time it takes to charge the external capacitor  $C_{REF}$ —see Figure 9. The time taken to charge  $C_{REF}$  to the 10-bit level is given by the equation  $(7.6 \times 2 \text{ k}\Omega \times C_{REF})$ . For  $C_{REF} = 10 \text{ nF}$  the power-up time is approximately 152  $\mu\text{s}$ . It takes 30  $\mu\text{s}$  to power up the on-chip reference so the total power-up time of either ADC in either of these conditions is 182  $\mu\text{s}$ . However, when powering down fully between conversions to achieve a better power performance this power-up time reduces to 1  $\mu\text{s}$  after a relatively short period of power-down as  $C_{REF}$  holds its charge (see On-Chip Reference section). The AD7811 and AD7812 can therefore be used in Mode 2 with throughput rates of 250 kSPS and under.

### Mode 2 Partial Power-Down (PD1 = 0, PD0 = 1)

The power-up time of the AD7811 and AD7812 from a Partial Power-Down is 1  $\mu\text{s}$  maximum. When using a Partial Power-Down between conversions, there is no requirement to connect an external capacitor to the  $C_{REF}$  pin because the reference remains powered up. This means that the AD7811 and AD7812 will power up in 30  $\mu\text{s}$  after the supplies are first connected as there is no requirement to charge an external capacitor.

## POWER VS. THROUGHPUT

By using the Automatic Power-Down (Mode 2) at the end of a conversion—see Operating Modes section of the data sheet, superior power performance can be achieved.

Figure 11 shows how the Automatic Power-Down is implemented using the  $\overline{\text{CONVST}}$  signal to achieve the optimum power performance for the AD7811 and AD7812. The AD7811 and AD7812 are operated in Mode 2 and the control register Bits PD1 and PD0 are set to 1 and 0 respectively for Full Power-Down, or 0 and 1 for Partial Power-Down. The duration of the  $\overline{\text{CONVST}}$  pulse is set to be equal to or less than the power-up time of the devices—see Operating Modes section. As the throughput rate is reduced, the device remains in its power-down state longer and the average power consumption over time drops accordingly.

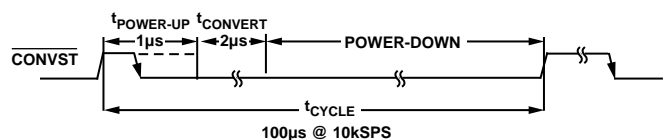
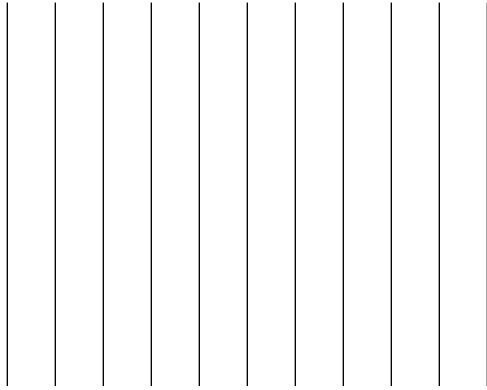

Figure 11. Automatic Power-Down

For example, if the AD7811 is operated in a continuous sampling mode with a throughput rate of 10 kSPS, PD1 = 1, PD0 = 0 and using the on chip reference the power consumption is calculated as follows. The power dissipation during normal operation is 10.5 mW,  $V_{DD} = 3$  V. If the power-up time is 1  $\mu$ s and the conversion time is 2.3  $\mu$ s, the AD7811 can be said to dissipate 10.5 mW for 3  $\mu$ s (worst case) during each conversion cycle. If the throughput rate is 10 kSPS, the cycle time is 100  $\mu$ s and the average power dissipated during each cycle is  $(3/100) \times (10.5 \text{ mW}) = 315 \mu\text{W}$ .

Figure 12 shows the Power vs. Throughput Rate for Automatic Full Power-Down.



# AD7811/AD7812

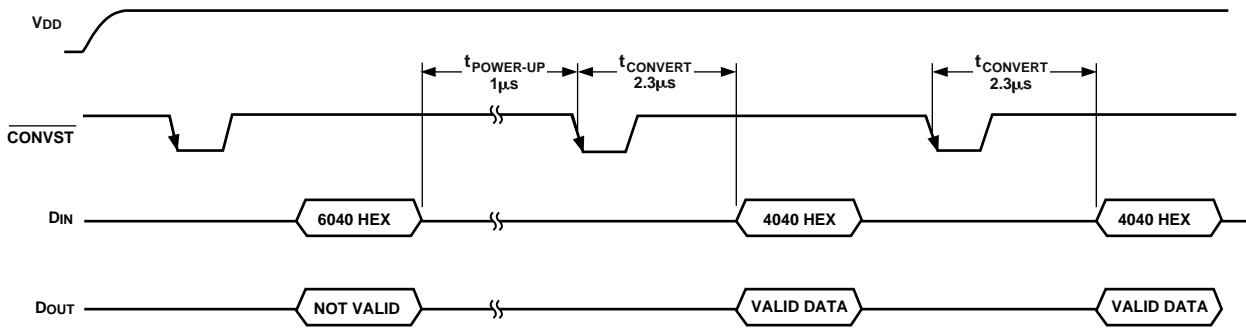

Figure 15. Read/Write Sequence for AD7812

## Mode 1 Operation (High Speed Sampling)

When the AD7811 and AD7812 are operated in Mode 1 they are not powered down between conversions. This mode of operation allows high throughput rates to be achieved. The timing diagram in Figure 16 shows how this optimum throughput rate is achieved by bringing the  $\overline{\text{CONVST}}$  signal high before the end of the conversion.

The sampling circuitry leaves its tracking mode and goes into hold on the falling edge of  $\overline{\text{CONVST}}$ . A conversion is also initiated at this time. The conversion takes 2.3  $\mu\text{s}$  to complete. At this point, the result of the current conversion is latched into the serial shift register and the state of the  $\overline{\text{CONVST}}$  signal checked. The  $\overline{\text{CONVST}}$  signal should be logic high at the end of the conversion to prevent the part from powering down. The serial port on the AD7811 and AD7812 is enabled on the rising edge of the first SCLK after the rising edge of the RFS signal—see Serial Interface section. As explained earlier, this rising edge

should occur before the end of the conversion process if the part is not to be powered down. A serial read can take place at any stage after the rising edge of  $\overline{\text{CONVST}}$ . If a serial read is initiated before the end of the current conversion process (i.e., at time “A”), the result of the previous conversion is shifted out on the  $\text{D}_{\text{OUT}}$  pin. It is possible to allow the serial read to extend beyond the end of a conversion. In this case the new data will not be latched into the output shift register until the read has finished. The dynamic performance of the AD7811 and AD7812 typically degrades by up to 3 dBs while reading during a conversion. If the user waits until the end of the conversion process, i.e., 2.3  $\mu\text{s}$  after the falling edge of  $\overline{\text{CONVST}}$  (Point “B”) before initiating a read, the current conversion result is shifted out. The serial read must finish at least 100 ns prior to the next falling edge of  $\overline{\text{CONVST}}$  to allow the part to accurately acquire the input signal.

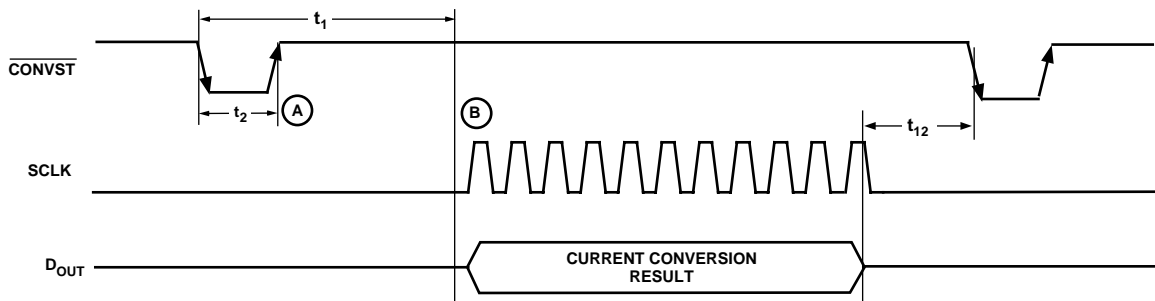

Figure 16. Mode 1 Operation Timing Diagram

## Mode 2 Operation (Automatic Power-Down)

When used in this mode of operation the part automatically powers down at the end of a conversion. This is achieved by leaving the  $\overline{\text{CONVST}}$  signal low until the end of the conversion. Because it takes approximately 1  $\mu\text{s}$  for the part to power-up after it has been powered down, this mode of operation is intended to be used in applications where slower throughput rates are required, i.e., in the order of 250 kSPS and improved power performance is required—see Power vs. Throughput section. There are two power-down modes the AD7811/AD7812 can enter during automatic power-down. These modes are discussed in the Power-Up Times section of this data sheet. The timing diagram in Figure 17 shows how to operate the part in

Mode 2. If the AD7811/AD7812 is powered down, the rising edge of the  $\overline{\text{CONVST}}$  pulse causes the part to power-up. Once the part has powered up (~1  $\mu\text{s}$  after the rising edge of  $\overline{\text{CONVST}}$ ) the  $\overline{\text{CONVST}}$  signal is brought low and a conversion is initiated on this falling edge of the  $\overline{\text{CONVST}}$  signal. The conversion takes 2.3  $\mu\text{s}$  and after this time the conversion result is latched into the serial shift register and the part powers down. Therefore, when the part is operated in Mode 2 the effective conversion time is equal to the power-up time (1  $\mu\text{s}$ ) and the SAR conversion time (2.3  $\mu\text{s}$ ).

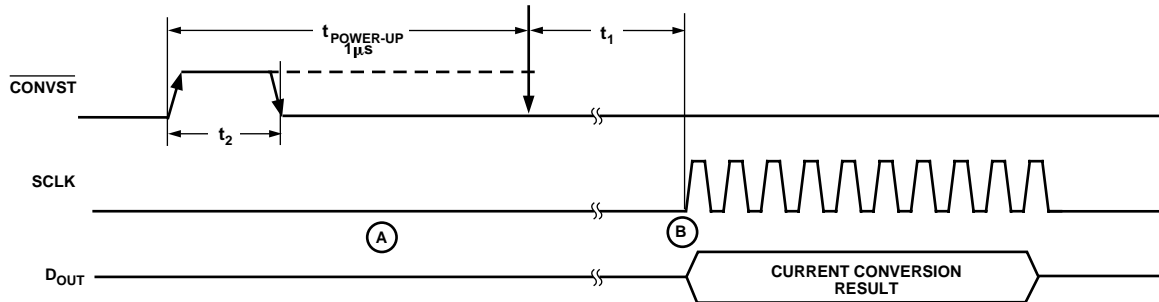

Figure 17. Mode 2 Operation Timing Diagram

NOTE: Although the AD7811 and AD7812 take  $1\ \mu\text{s}$  to power up after the rising edge of  $\overline{\text{CONVST}}$ , it is not necessary to leave  $\overline{\text{CONVST}}$  high for  $1\ \mu\text{s}$  after the rising edge before bringing it low to initiate a conversion. If the  $\overline{\text{CONVST}}$  signal goes low before  $1\ \mu\text{s}$  in time has elapsed, then the power-up time is timed out internally and a conversion is then initiated. Hence the AD7811 and AD7812 are guaranteed to have always powered-up before a conversion is initiated, even if the  $\overline{\text{CONVST}}$  pulsewidth is  $< 1\ \mu\text{s}$ . If the  $\overline{\text{CONVST}}$  pulsewidth is  $> 1\ \mu\text{s}$ , then a conversion is initiated on the falling edge.

As in the case of Mode 1 operation, the rising edge of the first SCLK after the rising edge of RFS enables the serial port of the AD7811 and AD7812 (see Serial Interface section). If a serial read is initiated soon after this rising edge (Point "A"), i.e., before the end of the conversion, the result of the previous conversion is shifted out on pin  $\text{D}_{\text{OUT}}$ . In order to read the result of the current conversion, the user must wait at least  $2.3\ \mu\text{s}$  after power-up or at least  $2.3\ \mu\text{s}$  after the falling edge of  $\overline{\text{CONVST}}$ , (Point "B"), whichever occurs latest before initiating a serial read. The serial port of the AD7811 and AD7812 is still functional even though the devices have been powered down.

Because it is possible to do a serial read from the part while it is powered down, the AD7811 and AD7812 are powered up only to do the conversion and are immediately powered down at the end of a conversion. This significantly improves the power consumption of the part at slower throughput rates—see Power vs. Throughput Rate section.

### SERIAL INTERFACE

The serial interface of the AD7811 and AD7812 consists of five wires, a serial clock input, SCLK, receive data to clock synchronization input RFS, transmit data to clock synchronization input TFS, a serial data output,  $\text{D}_{\text{OUT}}$ , and a serial data input,  $\text{D}_{\text{IN}}$ , (see Figure 18). The serial interface is designed to allow easy interfacing to most microcontrollers and DSPs, e.g., PIC16C, PIC17C, QSPI, SPI, DSP56000, TMS320 and ADSP21xx, without the need for any gluing logic. When interfacing to the 8051, the SCLK must be inverted. The Microprocessor/Microcontroller Interface section explains how to interface to some popular DSPs and microcontrollers.

Figure 18 shows the timing diagram for a serial read and write to the AD7811 and AD7812. The serial interface works with both a continuous and a noncontinuous serial clock. The rising edge of RFS and falling edge of TFS resets a counter that counts the number of serial clocks to ensure the correct number of bits are shifted in and out of the serial shift registers. Once the correct number of bits have been shifted in and out, the SCLK is ignored. In order for another serial transfer to take place the counter must be reset by the active edges of TFS and RFS. The first rising SCLK edge after the rising edge of the RFS signal causes  $\text{D}_{\text{OUT}}$  to leave its high impedance state and data is clocked out onto the  $\text{D}_{\text{OUT}}$  line and also on subsequent SCLK rising edges. The  $\text{D}_{\text{OUT}}$  pin goes back into a high impedance state on the 11th SCLK rising edge—Point "A" on Figure 18. A minimum of 11 SCLKs are therefore needed to carry out

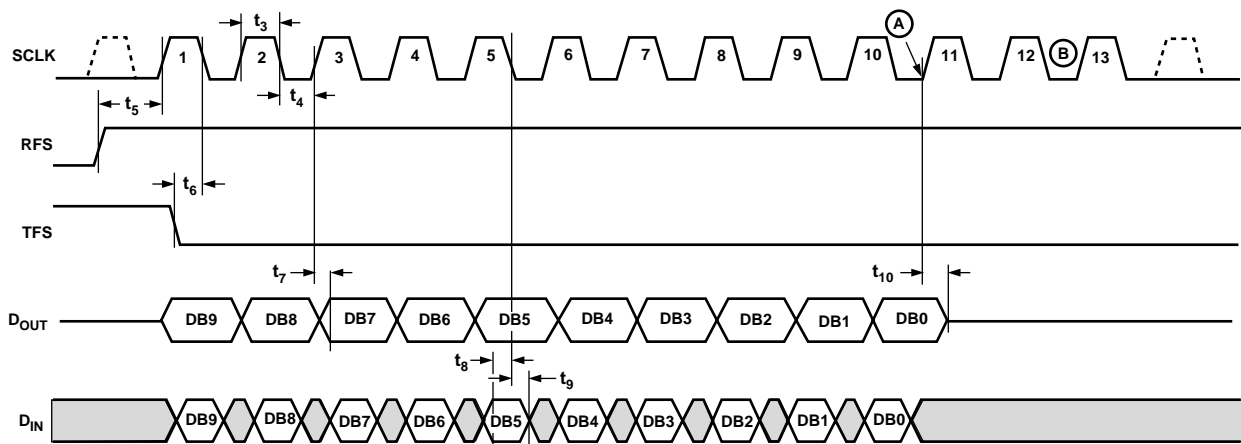

Figure 18. Serial Interface Timing Diagram

# AD7811/AD7812

a serial read. Data on the  $D_{IN}$  line is latched in on the first SCLK falling edge after the falling edge of the TFS signal and on subsequent SCLK falling edges. The control register is updated on the 13th SCLK rising edge—point “B” on Figure 18. A minimum of 13 SCLK pulses are therefore needed to complete a serial write operation. In multipackage applications the RFS and TFS signals can be used as chip select signals. The serial interface will not shift data in or out until it receives the active edge of the RFS or TFS signal.

## Simplifying The Serial Interface

The five-wire interface is designed to support many different serial interface standards. However, it is possible to reduce the number of lines required to just three. By simply connecting the TFS and RFS pins to the  $\overline{CONVST}$  signal (see Figure 4), the  $\overline{CONVST}$  signal can be used to enable the serial port for reading and writing. This is only possible where a noncontinuous serial clock is being used.

## MICROPROCESSOR INTERFACING

The Serial Interface on the AD7811 and AD7812 allows the parts to be directly connected to a range of many different microprocessors. This section explains how to interface the AD7811 and AD7812 with some of the more common microcontroller and DSP serial interface protocols.

### AD7812/AD7811 to PIC16C6x/7x

The PIC16C6x Synchronous Serial Port (SSP) is configured as an SPI Master with the Clock Polarity bit = 0. This is done by writing to the Synchronous Serial Port Control Register (SSPCON). See user PIC16/17 Microcontroller User Manual. Figure 19 shows the hardware connections needed to interface to the PIC16/17. In this example I/O port RA1 is being used to pulse  $\overline{CONVST}$  and enable the serial port of the AD7811/AD7812. This microcontroller transfers only eight bits of data during each serial transfer operation; therefore, two consecutive read/write operations are needed.

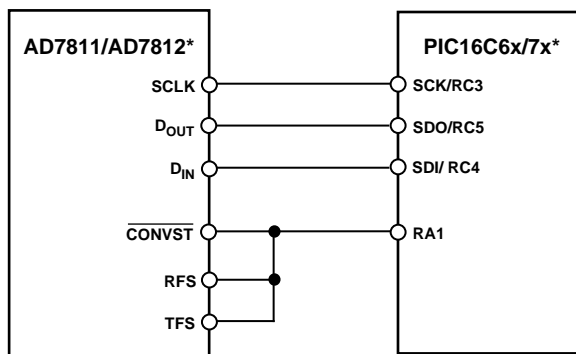

Figure 19. Interfacing to the PIC16/17

### AD7811/AD7812 to MC68HC11

The Serial Peripheral Interface (SPI) on the MC68HC11 is configured for Master Mode (MSTR = 0), Clock Polarity Bit (CPOL) = 0 and the Clock Phase Bit (CPHA) = 1. The SPI is configured by writing to the SPI Control Register (SPCR)—see 68HC11 user manual. A connection diagram is shown in Figure 20.

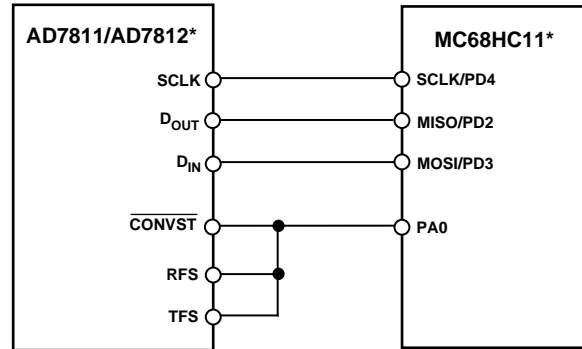

Figure 20. Interfacing to the MC68HC11

### AD7811/AD7812 TO 8051

The AD7811/AD7812 requires a clock synchronized to the serial data. The 8051 serial interface must therefore be operated in Mode 0. In this mode serial data enters and exits through RXD and a shift clock is output on TXD (half duplex). Figure 21 shows how the 8051 is connected to the AD7811/AD7812. However, because the AD7811/AD7812 shifts data out on the rising edge of the shift clock and latches data in on the falling edge, the shift clock must be inverted.

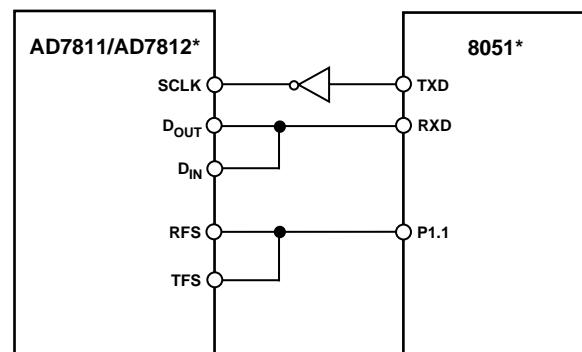
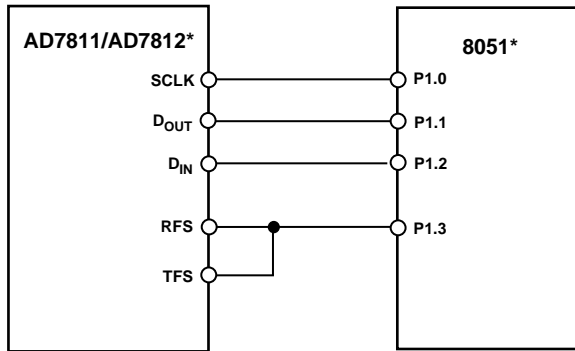

Figure 21. Interfacing to the 8051 Serial Port

It is possible to implement a serial interface using the data ports on the 8051. This would also allow a full duplex serial transfer to be implemented. The technique involves “bit banging” an I/O port (e.g. P1.0) to generate a serial clock and using two other I/O ports (e.g. P1.1 and P1.2) to shift data in and out—see Figure 22.





\*ADDITIONAL PINS OMITTED FOR CLARITY

Figure 22. Interfacing to the 8051 Using I/O Ports

### AD7811/AD7812 to TMS320C5x

The Serial interface on the TMS320C5x uses a continuous serial clock and frame synchronization signals to synchronize the data transfer operations with peripheral devices like the AD7811. Frame synchronization inputs have been supplied on the AD7811/AD7812 to allow easy interfacing with no extra gluing logic. The serial port of the TMS320C5x is set up to operate in Burst Mode with internal CLKX (TX serial clock) and FSX (TX frame sync). The Serial Port Control register (SPC) must have the following setup: F0 = 0, FSM = 1, MCM = 1 and TXM = 1. The connection diagram is shown in Figure 23.

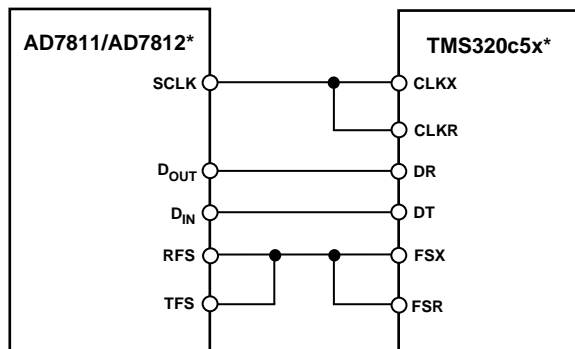

\*ADDITIONAL PINS OMITTED FOR CLARITY

Figure 23. Interfacing to the TMS320c5x

### AD7811/AD7812 to ADSP21xx

The ADSP21xx family of DSPs are easily interfaced to the AD7811/AD7812 without the need for extra gluing logic. The SPORT is operated in normal framing mode. The SPORT control register should be set up as follows:

TFSW = RFSW = 0, Normal Framing  
 INVRFS = INVTFS = 0, Active High Frame Signal  
 DTYPE = 00, Right Justify Data  
 SLEN = 1001, 10-Bit Data Words  
 ISCLK = 1, Internal Serial Clock  
 TFSR = RFSR = 1, Frame Every Word  
 IRFS = 0, External Framing Signal  
 ITFS = 1, Internal Framing Signal

The 10-bit data words will be right justified in the 16-bit serial data registers when using this configuration. Figure 24 shows the connection diagram.

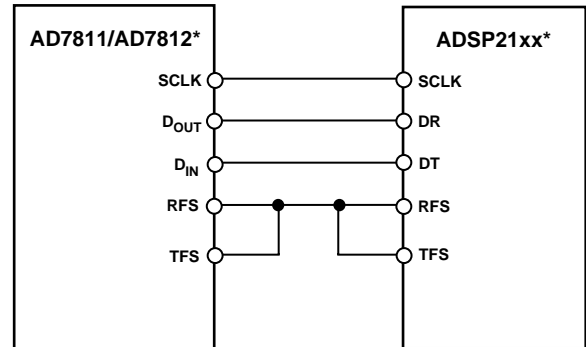

\*ADDITIONAL PINS OMITTED FOR CLARITY

Figure 24. Interfacing to the ADSP21xx

### AD7811/AD7812 to DSP56xxx

The connection diagram in Figure 25 shows how the AD7811 and AD7812 can be connected to the SSI (Synchronous Serial Interface) of the DSP56xxx family of DSPs from Motorola. The SSI is operated in Synchronous Mode (SYN bit in CRB = 1) with internally generated 1-bit clock period frame sync for both TX and RX (FSL1 and FSL0 bits in CRB = 1 and 0 respectively).

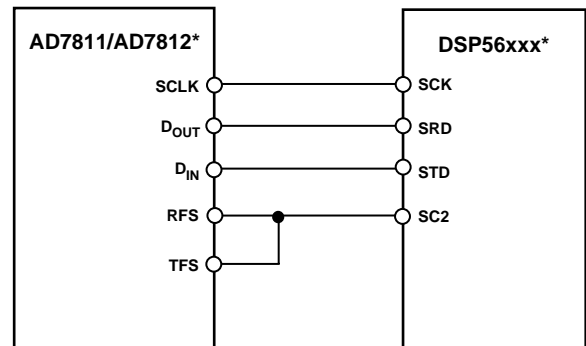

\*ADDITIONAL PINS OMITTED FOR CLARITY

Figure 25. Interfacing to the DSP56xxx

# AD7811/AD7812

## OUTLINE DIMENSIONS

Dimensions shown in inches and (mm).

### 16-Lead Plastic DIP (N-16)

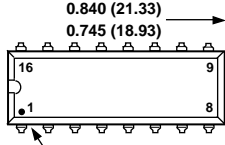

**OUTLINE DIMENSIONS**

Dimensions shown in inches and (mm).

**20-Lead Plastic DIP  
(N-20)**

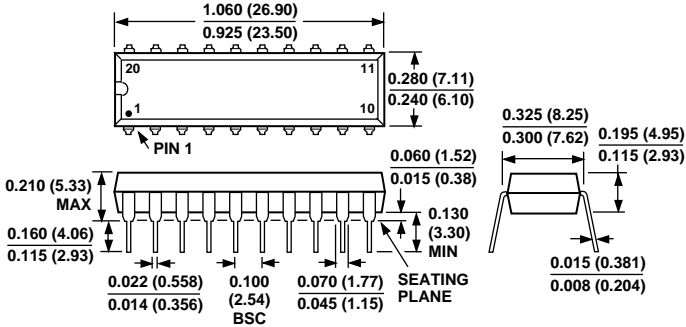

**20-Lead Small Outline Package (SOIC)  
(R-20A)**

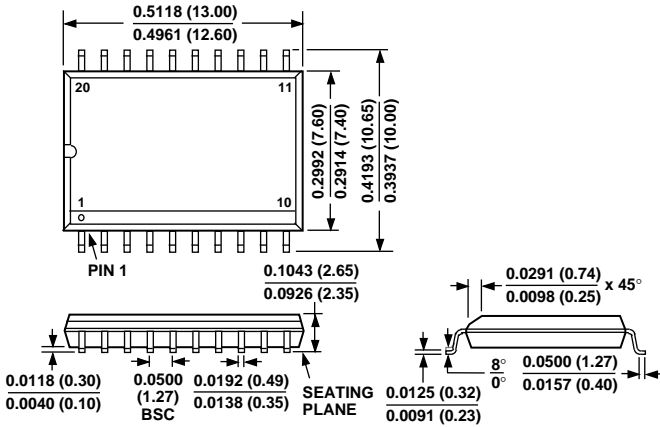

**20-Lead Thin Shrink Outline Package (TSSOP)  
(RU-20)**

