

**Top View of Assembly**

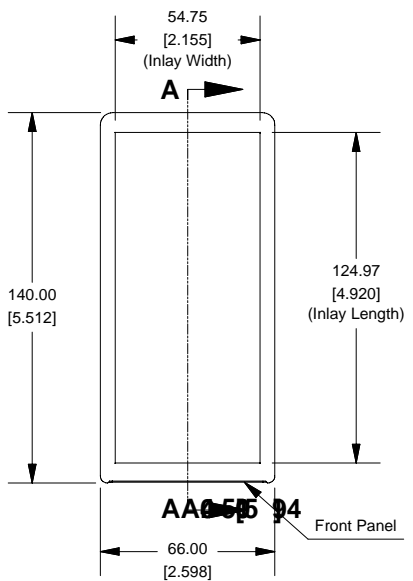

**SECTION A-A  
(Side View Inside Assembly)**

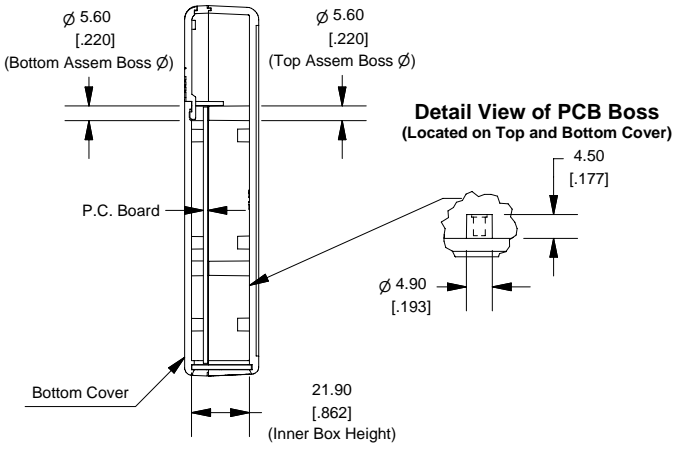

**Detail View of PCB Boss  
(Located on Top and Bottom Cover)**

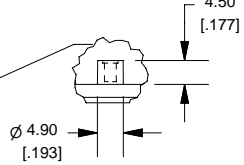

**End View of Assembly**

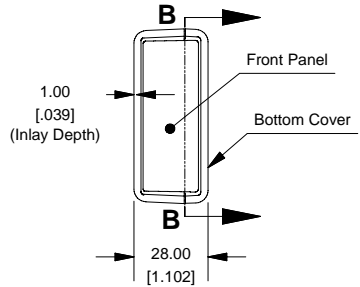

**SECTION B-B  
(Inside of Bottom Cover)**

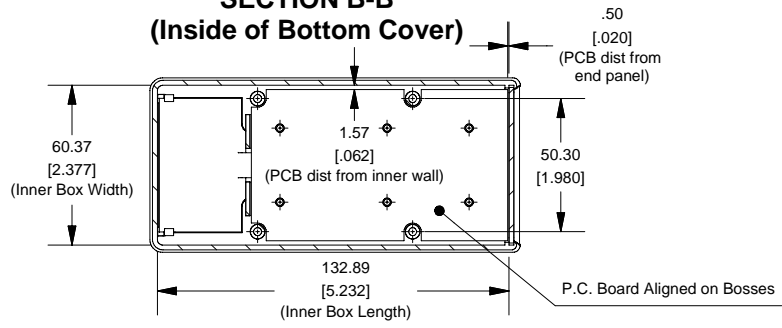

**Maximum P.C. Board Size**

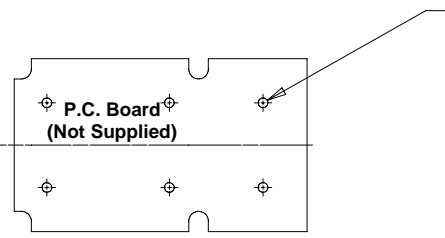

**Front/Rear Panel  
(Dashed Line Indicates Viewing Area)**

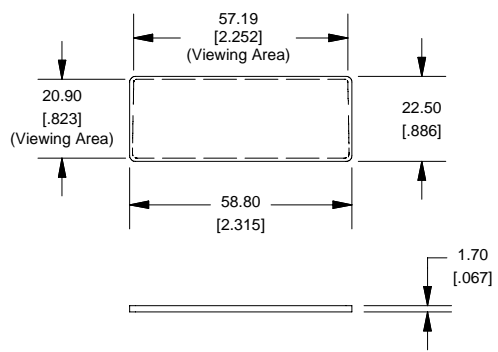

**Hand Held Instrument (1593Y)**

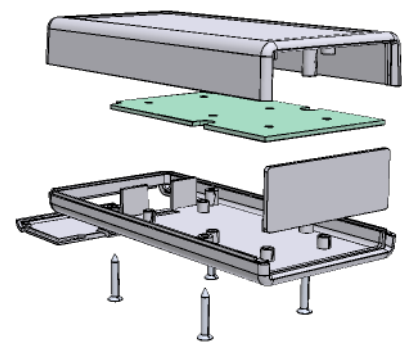

Enclosures can be Factory Modified ( Milling, Drilling, Printing etc. )  
Solid models of this enclosure available in STEP or IGES.  
Contact Factory [mjm@hammondmfg.com](mailto:mjm@hammondmfg.com)

NOTE	
Enclosure molded from GP ABS (UL94-HB) plastic.	
Purchased assembly includes top and bottom cover, front panel (plastic), battery door and 4 cover screws.	

PART NUMBERS	
1593Y Enclosure	
Black Enclosure	1593YBK
Grey Enclosure	1593YGY
ACCESSORIES	
Cover Screws (Pkg 100) [#4 x 3/4" self-tapping oval head (19.1mm)]	1593QS100 (Silver) 1593QS100BK (Black)
P.C. Board Screws [#4 x 1/4" self-tapping (6.4mm)]	1593ATS50 (Pkg 50) 1593ATS100 (Pkg 100)
Belt or Pocket Clip	1599CLIP (Black) 1599CLIPGY (Grey)
Infrared Panels (Pkg 10)	1593DIR10

**HAMMOND  
MANUFACTURING™**

**1593Y**

[www.hammondmfg.com](http://www.hammondmfg.com)