

RECOMMENDED MOUNTING PAD

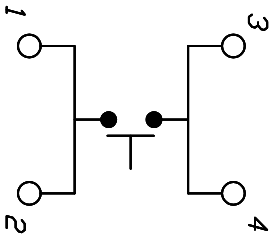

CIRCUIT: SPST

NOTES:

1. ALL DIMENSIONS IN MM [INCH]
2. GENERAL TOLERANCE: X.X=±0.4 X.XX=±0.25
3. TERM. NOS. FOR REFERENCE ONLY.
4. RATINGS: 12VDC, 50mA
5. CONTACT MATERIAL: Silver
6. OPERATING FORCE: 160±50gf
7. TRAVEL: 0.25±0.1mm
8. CONTACT RESISTANCE: 100 MILLI Ω Max.
9. ELECTRICAL LIFE: 100,000 CYCLES min.
- ▲10. DESIGNATE MAJOR FEATURE:
- ▲11. BODY & STEM: HIGH TEMP. PLASTIC (B)
- ▲12. PACKAGED: TAPE & REEL, 250 PER REEL
13. 2002/95/EC (ROHS) COMPLIANT.

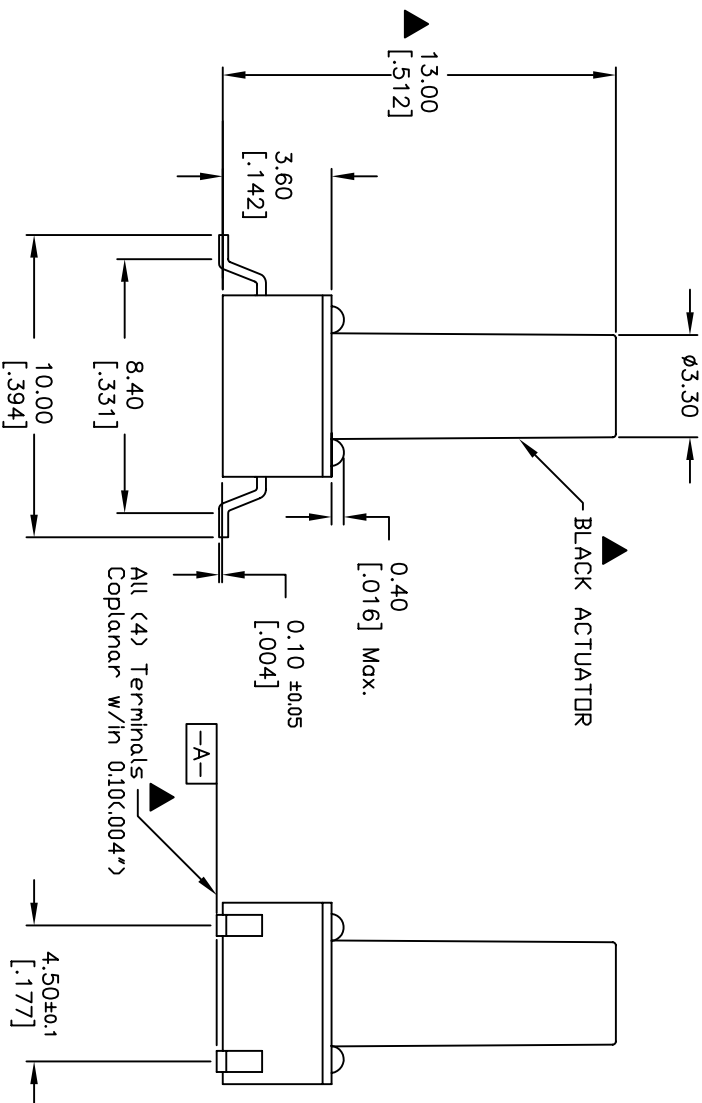

REV.	ECN No.	DESCRIPTION	DATE	CHKD
C	16580	UPDATED NOTES	10/25/06	TN
B	13622	REMOVE R4 MATERIAL	11/25/03	AR
A	11584	RELEASED FOR PRODUCTION	10/28/02	CJB

SCALE	DATE	DR	DWG	REV
4:1	10/28/02	CJB	D310615	C

THE INFORMATION CONTAINED IN THIS DOCUMENT IS PROPRIETARY TO E-SWITCH AND IS NOT TO BE COPIED OR TRANSMITTED

TL3301DF1600G

TITLE

DATE

DR

DWG

REV