

Panel and Legend Mounts for LED Light Bars

Technical Data

HLMP-2598
HLMP-2599
HLMP-2898
HLMP-2899

Features



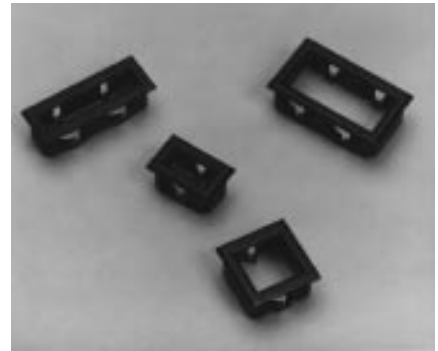

- **Firmly Mounts Light Bars in Panels**
- **Holds Legends for Front Panel or PC Board Applications^[1]**
- **One Piece, Snap-in Assembly**
- **Matte Black Bezel Design Enhances Panel Appearance**
- **Four Sizes Available**
- **May Be Installed in a Wide Range of Panel Thicknesses**
- **Panel Hole Easily Punched or Milled**

Description

This series of black plastic bezel mounts is designed to install Agilent Light Bars in instrument panels ranging in thickness from 1.52 mm (0.060 inch) to 3.18 mm (0.125 inch). A space has been provided for holding a 0.13 mm (0.005 inch) film legend over the light emitting surface of the light bar module.



Selection Guide

Panel and Legend Mount Part No. HLMP-	Corresponding Light Bar Module Part No.		Panel Hole Installation Dimensions ^[2]	Package Outline	
	HLCP-	HLMP-			B
2598	B100	2350, 2450, 2550	7.62 mm (0.300 inch) x 22.86 mm (0.900 inch)		B
2599	A100	2300, 2400, 2500	7.62 mm (0.300 inch) x 12.70 mm (0.500 inch)		A
2898	D100 C100	2600, 2700, 2800 2655, 2755, 2855 2950, 2965, 2980	12.70 mm (0.500 inch) x 12.70 mm (0.500 inch)		C
2899	E100 F100 G100 H100	2620, 2720, 2820 2635, 2735, 2835 2670, 2770, 2870 2685, 2785, 2885	12.70 mm (0.500 inch) x 22.86 mm (0.900 inch)		D

Notes:

1. Application Note 1012 addresses legend fabrication options.
2. Allowed hole tolerance: +0.00 mm, -0.13 mm (+0.000 inch, -0.005 inch). Permitted radius: 1.60 mm (0.063 inch).

Package Dimensions

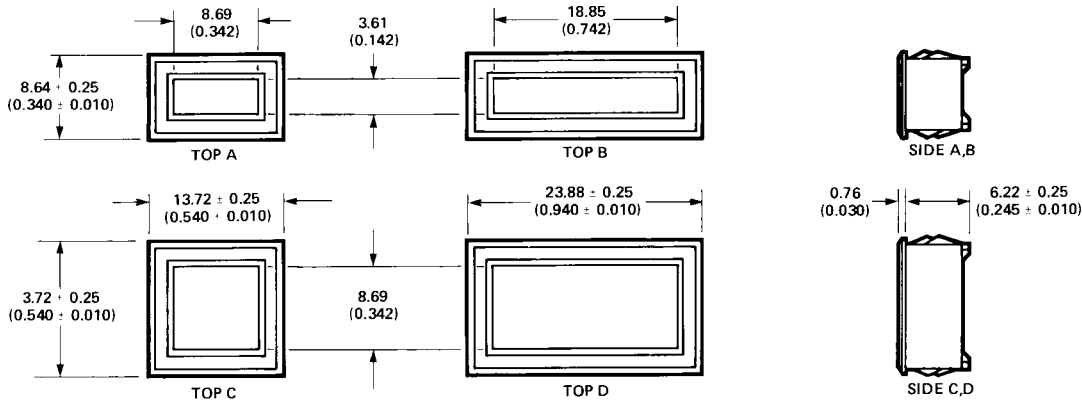

NOTES: 1. DIMENSIONS IN MILLIMETRES (INCHES)
2. UNTOLERANCED DIMENSIONS ARE FOR REFERENCE ONLY.

Mounting Instructions

1. Mill^[3] or punch a hole in the panel. Deburr, but do not chamfer, the edges of the hole.
2. Place the front of the mount against a solid, flat surface. A film legend with outside dimensions equal to the outside dimensions of the light bar may be placed in the mount or on the light bar light emitting surface. Press the light bar into the mount until the tabs snap over the back of the light bar^[4]. When inserting the HLMP-2898, align the notched sides of the light bar with the mount sides which do not have the tabs. (See Figure 1.)

3. Applying even pressure to the top of the mount, press the entire assembly into the hole from the front of the panel^[5]. (See Figure 2.)

Note: For thinner panels, the mount may be pressed into the panel first, then the light bar may be pressed into the mount from the back side of the panel.

Suggested Punch Sources

Hole punches may be ordered from one of the following sources:

Danly Machine Corporation
Punchrite Division
15400 Brookpark Road
Cleveland, OH 44135
(216) 267-1444

Ring Division
The Producto Machine Company
Jamestown, NY 14701
(800) 828-2216

Porter Precision Products
Company
12522 Lakeland Road
Santa Fe Springs, CA 90670
(213) 946-1531

Di-Acro Division
Houdaille Industries
800 Jefferson Street
Lake City, MN 55041
(612) 345-4571

Notes:

3. A 3.18 mm (0.125 inch) diameter mill may be used.
4. Repetitive insertion of the light bar into mount may cause damage to the mount.
5. Repetitive insertion of the mount into the panel will degrade the retention force of the mount.

Installation Sketches

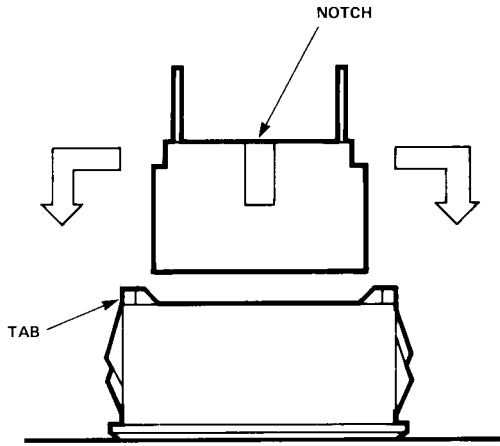

Figure 1. Installation of a Light Bar into a Panel Mount.

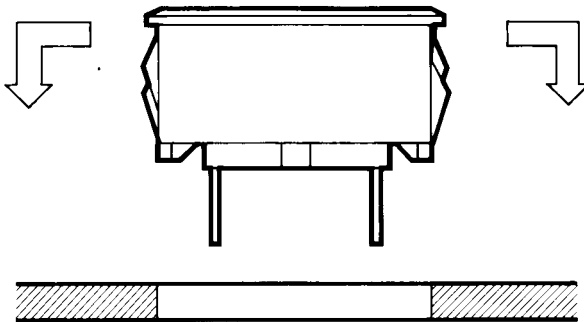

Figure 2. Installation of the Light Bar/Panel Mount Assembly into a Front Panel.

