

Top View

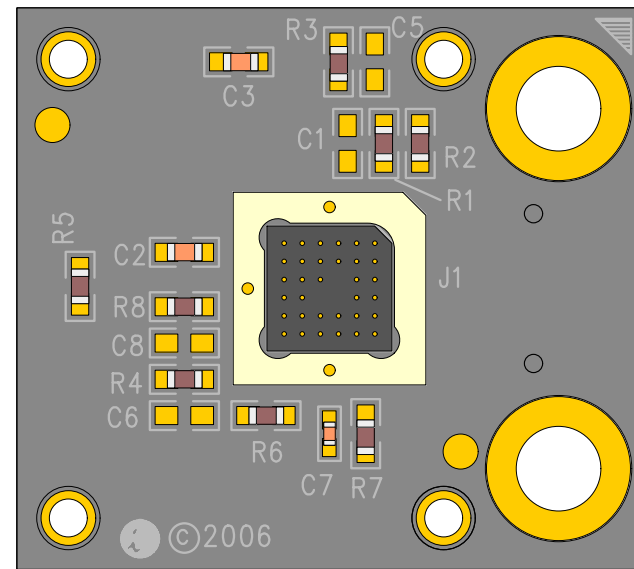

Bottom View

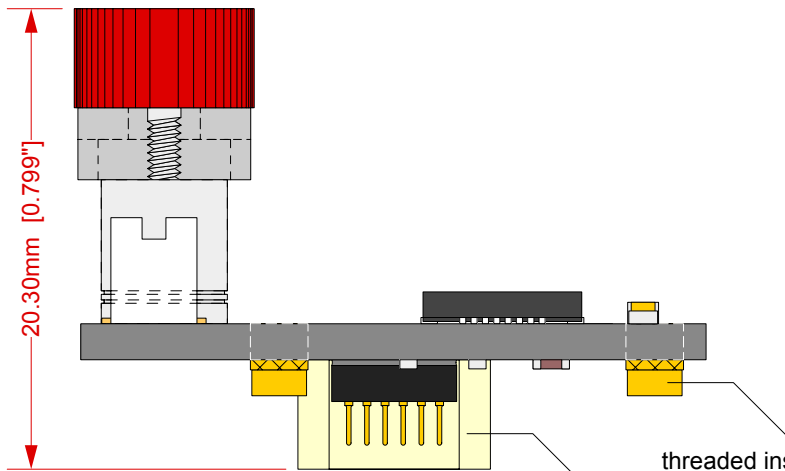

Side View

threaded inserts for mounting hardware
UGA Male pin shroud

Description: CY3250-20434QFN POD

48 pin QFN OCD with Hirose cable connector (P/N: DF12-5.0-20DP-0.5V-81) with retention mechanism included.
Compatible with:
SF-QFN32A-L-02, QFN foot, 32 pin, 0.5mm pitch, 5mm body
XT-PSoC-15-20H-10-01

Strain Relief Hardware mounting directions

If the target board can be designed to accommodate the strain relief hardware, layout the PCB with the pattern shown on the right. The layout shows the location of non-plated holes through the board relative to the QFN land pattern. If holes can not be added to the target board, the screws can be used as standoffs and sit on the top surface of the target PCB.

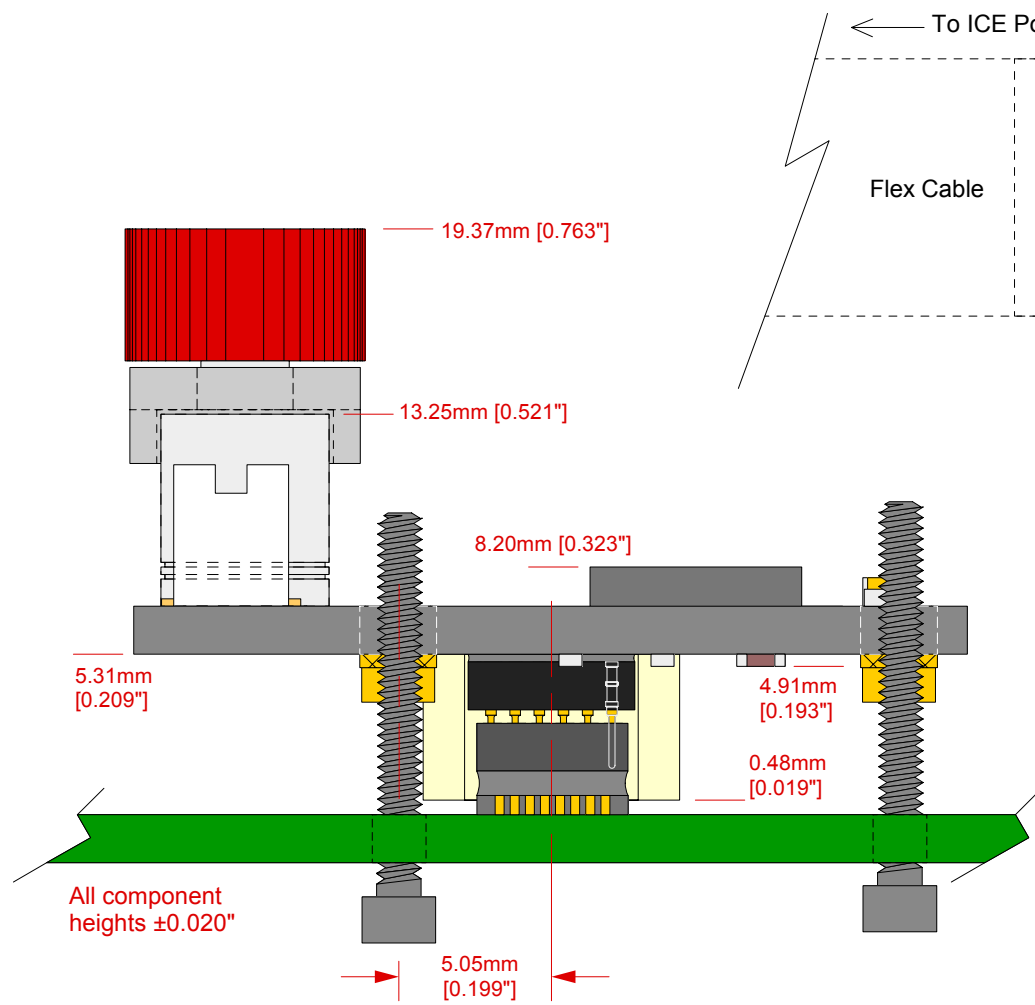

All component heights ± 0.020 "

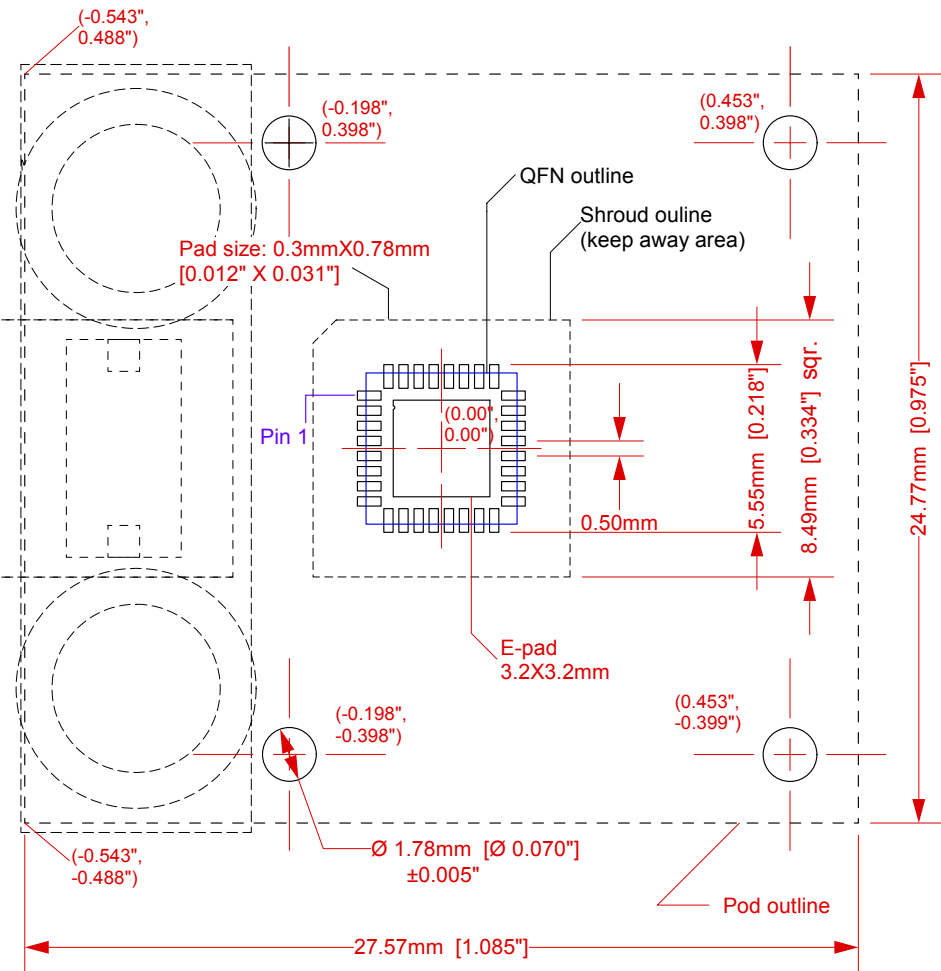

Top View: Target Board component layout

notes:

- 1) Do not place components within the shroud outline unless they have a 0.035" height or less off the target board and are outside the QFN package outline
- 2) All components under the POD outline must have a 0.190" height or less from the top of target board to avoid components on the bottom of the POD board.

Side view: CY3250-20434QFN Pod on QFN32 foot

	EA-8C2000-Q32-01 Drawing © 2006 IRONWOOD ELECTRONICS, INC. PO BOX21151 ST. PAUL, MN 55121 Tele: (651) 452-8100 www.ironwoodelectronics.com	Status: Preliminary	Scale: 4:1	Rev: B
	Drawing: M. Tully	Date: 4/11/06	File: EA-8C2000-Q32-01 Dwg	Modified: 1/11/07, MT

Tolerances: diameters $\pm 0.03\text{mm}$ [± 0.001 "],
 PCB perimeters $\pm 0.13\text{mm}$ [± 0.005 "],
 PCB thicknesses $\pm 0.18\text{mm}$ [± 0.007 "],
 pitches (from true position) $\pm 0.08\text{mm}$ [± 0.003 "],
 all other tolerances $\pm 0.13\text{mm}$ [± 0.005 "]
 unless stated otherwise. Materials and specifications are subject to change without notice.