



# Solid State Timers and Controllers

## 4600

### Repeat Cycle Timer



The model 4600 series is a true repeat cycle timer, not an ON-OFF cycle timer. Once the Repeat Cycle Time has been set, any variation of the Energize Time will not effect the Repeat Cycle Time. The 4600 series was developed to emulate the older electromechanical synchronous motor type of repeat cycle timer. In the older electromechanical repeat cycle timers, a cam closed a switch on each rotational cycle of the motor. The cam driven rotational cycle has been replaced by the Repeat Cycle Time portion of the 4600. The switching action of the electromechanical timer has been replaced

by a solid state switch energizing on each repeat cycle. This portion of the cycle is referred to as the Energize Time. The cams were adjustable to provide switch closures from approximately 5% to nearly 100% of the total cycle time. To emulate this range of switch closure, the Artisan Controls series 4600 has been divided into two models. One model, the 4600F, will permit the Energize Time to be specified from as low as 100 milliseconds to nearly 90% of the Repeat Cycle. Adjustable timing models require 2 separate models to cover the range of Energize Time from 1% to 50%, and 50% to 100% of the Repeat Cycle Time. The output of the model 4600 is a 1 ampere solid state switch. The model 4600 is available in both AC and DC models.

### Mechanical & Wiring

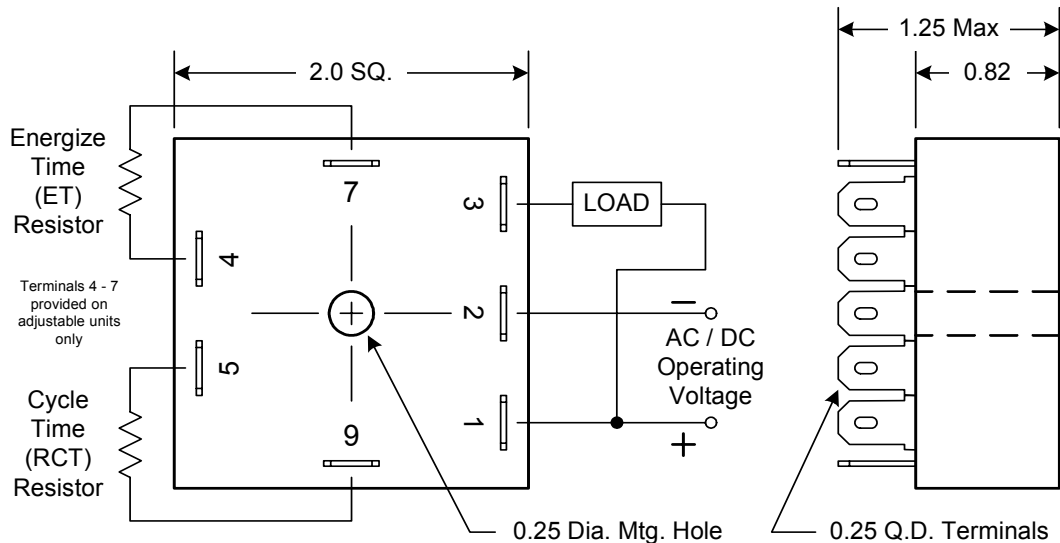

### Timing Diagram

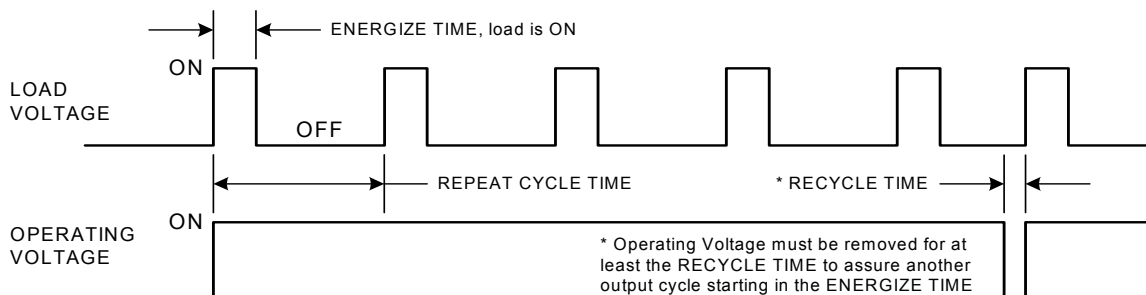

VISIT OUR WEB SITE AT: [www.artisancontrols.com](http://www.artisancontrols.com)

**Notice:** Artisan Controls Corporation assumes no responsibility for customers applications or product design. The information and data contained herein is the sole and exclusive property of Artisan Controls Corporation. Any duplication, misuse, or conversion of this information without the express written consent of Artisan Controls Corporation is illegal and will result in damages including court costs and attorney fees being assessed against the party misusing this property

**Tel: 973-598-9400 • Fax: 973-598-9410 • Toll Free: 800-457-4950**  
 Artisan Controls Corporation, 111 Canfield Ave., Bldg B15-18, Randolph, NJ, 07869, USA



# Solid State Timers and Controllers

## External Timing Resistance Table ( 0 To 10 Meg Ohm Range ) . . . . .

External Timing Resistor in Ohms	REPEAT CYCLE TIME (RCT)				
	-1	-2	-3	-4	-5
0 Ohms	0.2	2	4	20	60
1 MEG	8	60	200	1000	1800
3 MEG	24	180	600	3000	5400
5 MEG	40	300	1000	5000	9000
10 MEG	60	600	2000	9000	16000
Repeat Cycle Times (RCT) in Seconds					

The *External Timing Resistor* value shown illustrates the range of RCT (Repeat Cycle Time) that can be achieved with any of the five dash numbers.

Ex: The -3 will have a RCT of 4 seconds when the external resistor is set to 0 ohms (a short). If a 1 meg ohm potentiometer is connected across the RCT timing terminals, the RCT will be able to be adjusted from 4 to 200 seconds. If a 10 meg ohm potentiometer is used, the range will be 4 to 2000 seconds.

Note: the ET (*Energize Time*) will range from 0 to 50% of the RCT for the -A *Range Restriction*, and 50% to 100% for the -B *Range Restriction* using the same value potentiometer as is used to set the RCT

## Ordering Information . . . . .

Model	Voltage	RCT Time	RCT Tolerance	ET Time	ET Tolerance
4600F Fixed Timing	-1 12V DC	Specify the Fixed Repeat Cycle Time (RCT) In Seconds From 0.2 to 86,400	-A 2% -B 5% -C 10% -D 20%	Specify the Fixed Energize Time (ET) In Seconds From 0.1 to 90% of the RCT	-A 2% -B 5% -C 10% -D 20%
	-2 24V DC				
	-3 48V DC				
	-4 24V AC				
	-5 48V AC				
	-6 115V AC				
	-7 230V AC				

Model	Voltage	RCT Time	ET Range
4600A Adjustable Timing	-1 12V DC	-1 0.2 - 60 -2 2 - 600 -3 4 - 2,000 -4 20 - 9,000 -5 60 - 16,000	-A Energize Time is 1% - 50% of Repeat Cycle Time
	-2 24V DC		
	-3 48V DC		
	-4 24V AC		
	-5 48V AC		
	-6 115V AC		
	-7 230V AC		
		-B Energize Time is 50% - 100% of Repeat Cycle Time	

**Example No. 1: 4600A-8-3-A** Is a model 4600A with 115V AC operating voltage with an adjustable Repeat Cycle Time (RCT) from 4 to 2,000 seconds, and an adjustable Energize Time (ET) from 2 to 1,000 seconds. The ET is adjustable up to a maximum of 50% of whatever the Repeat Cycle Time (RCT) is set for.

**Example No. 2: 4600A-2-1-B** Is a model 4600A with 24V DC operating voltage with an adjustable Repeat Cycle Time (RCT) from 0.2 to 60 seconds, with adjustable Energize Time (ET) from 0.2 to 60 seconds. The adjustable ET will always be added to 50% of whatever the Repeat Cycle Time (RCT) is set for. If the RCT were set to 10 seconds, the ET would be 5 - 10 seconds.

**Example No. 3: 4600F-6-600-C-150-C** Is a model 4600F with 24V AC operating voltage with a fixed Repeat Cycle Time (RCT) of 600 seconds, and a fixed Energize Time (ET) of 150 seconds. Both RCT and ET have a fixed 10% tolerance.

VISIT OUR WEB SITE AT : [www.artisancontrols.com](http://www.artisancontrols.com)

**Notice:** Artisan Controls Corporation assumes no responsibility for customers applications or product design. The information and data contained herein is the sole and exclusive property of Artisan Controls Corporation. Any duplication, misuse, or conversion of this information without the express written consent of Artisan Controls Corporation is illegal and will result in damages including court costs and attorney fees being assessed against the party misusing this property



## Solid State Timers and Controllers

### Specifications

- Operating Voltage:** 12VDC (10V-16V), 24VDC (18V-30V), 48V DC (40V - 60V) all DC models are polarity sensitive and require a maximum of 10mA of operating current plus output load current. 24VAC (18V - 30V), 48V AC (40V - 60V), 115VAC (95V - 135V), 230VAC (200V - 250V), 50/60Hz. (10mA). All AC voltages require a max. of 10 mA of operating current plus load current.
- Timing Mode:** Repeat Cycle Timing - Energize portion of cycle turns on with application of operating voltage.
- Fixed Timing:** Repeat Cycle Time from 0.2 seconds to 86,400 seconds. Energize Time from 0.1 seconds to 90% of the Repeat Cycle Time.
- Fixed Timing Purchase Tolerance:** 2%, 5%, 10%, and 20% available.
- Adjustable Timing Ranges:** 20 ranges of adjustable Repeat Cycle Times from 5 models.
- Energize Time Range Restrictions:** Adjustable energize times (ET) require a range restriction code 'A', or 'B' to be added to the part number. The '-A' restricts the Energize Time (ET) between 1% and 50% of whatever the Repeat Cycle Time (RCT) is set for. The '-B' restricts the Energize Time (ET) between 50% and 100% of whatever the Repeat Cycle Time (RCT) is set for.
- Timing Range Tolerance:** Minimum time  $\pm 10\%$ , maximum time  $\pm 10\%$ . Example: The RCT adjustable timing range -3 operates in the 4 - 200 second range with 0 - 1 meg ohm external timing resistor. This model could exhibit a minimum time of 3.6 - 4.4 seconds with 0 ohms external timing resistance, and a maximum time of 180 - 220 seconds with an external timing resistor of 1 meg ohm. The extended range to 2000 seconds using 10 meg ohms external timing resistance is permitted to be 1800 - 2200 seconds, and still fall within the  $\pm 10\%$  specification limit.
- Timing Resistor Rating:** Worst case power dissipation never exceeds 15 milliwatts.
- Timing Resistor Tolerance:** Timing range specified is guaranteed as a minimum using 5% resistors.
- Timing Variation:** Less than 6% of set point over specified temperature and voltage range.
- Repeatability Of Timing Period:**  $\pm 1\%$  nominal.
- Recycle Time:** Operating voltage must be removed for a minimum of 200 milliseconds to guarantee all timing and output circuits have reset.
- Output:** Solid state switch closed during the energize time.
- Output Switch Rating:** 10 milliamperes to 1 ampere inductive with inrush current to 25 amperes for 8 milliseconds.
- Output Switch Characteristics:** Voltage drop across the solid state switch in the energized mode is 2 volts maximum for DC models, and 4 volts maximum for AC models. The leakage current through the solid state output switch when output is not energized is 1 milliamperes maximum for DC models, and 3 milliamperes maximum for AC models.
- Transient Protection:** Protected by silicon transient suppressors which respond to transients
- Dielectric:** within  $1 \times 10^{-12}$  seconds to a peak pulse power dissipation of 1500 watts, with transient surge currents to 200 amperes for durations up to 1/120 second at 25° C. Maximum transient voltage protection is 6000 volts as delivered through a source resistance of 30 ohms with a maximum duration of 8.3 milliseconds.  
1500V rms all terminals to case.
- Operating Temperature:** -20°C to +85°C.
- Humidity:** 95% non-condensing.
- Construction:** Encapsulated module with .25 quick connect wiring terminals.
- Agency Recognitions:** UL File E47858, Component Appliance Controls ATNZ2 (US) & ATNZ8 (Can) Component Auxiliary Devices NKCR2 (US) & NKCR8 (Can).
- Data Sheet Revision Date:** January 13, 2006

VISIT OUR WEB SITE AT: [www.artisancontrols.com](http://www.artisancontrols.com)

**Notice:** Artisan Controls Corporation assumes no responsibility for customers applications or product design. The information and data contained herein is the sole and exclusive property of Artisan Controls Corporation. Any duplication, misuse, or conversion of this information without the express written consent of Artisan Controls Corporation is illegal and will result in damages including court costs and attorney fees being assessed against the party misusing this property

**Tel: 973-598-9400 • Fax: 973-598-9410 • Toll Free: 800-457-4950**  
Artisan Controls Corporation, 111 Canfield Ave., Bldg B15-18, Randolph, NJ, 07869, USA