

Spezifikation für Freigabe / specification for release

Kunde / customer :
 Artikelnummer / part number : **749013040**
 Bezeichnung : **LAN-Übertrager WE-LAN**
 description : **LAN-Transformer WE-LAN**



DATUM / DATE : 2011-01-10

H Schaltbild / Schematics :

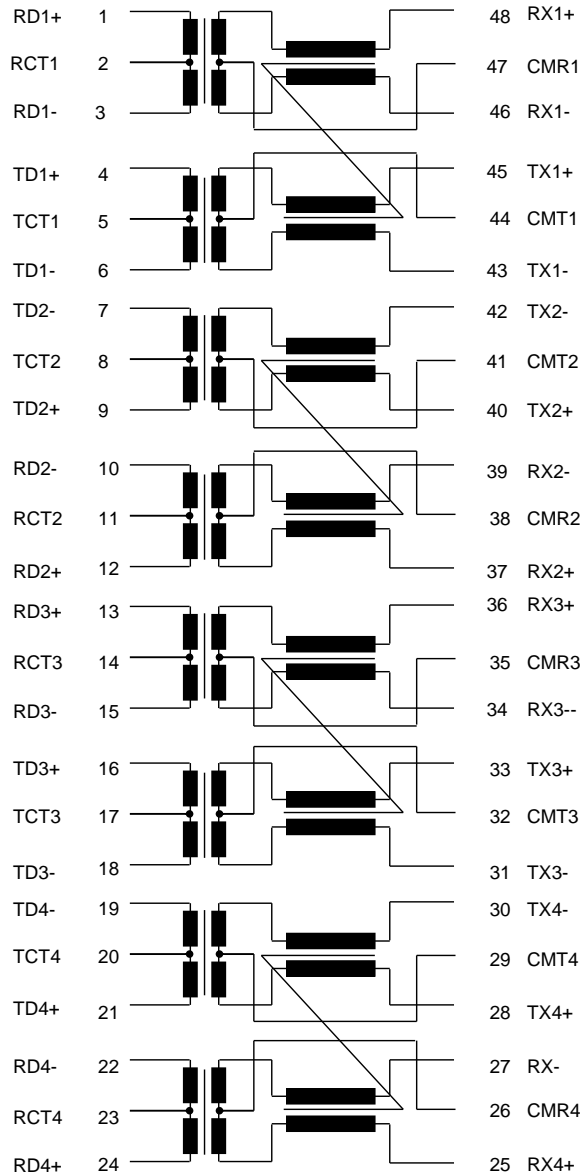

Freigabe erteilt / general release:	Kunde / customer			
.....			
Datum / date	Unterschrift / signature	Mle	Version 4	2012-01-10
.....	Würth Elektronik	TBr	Version 3	2005-07-15
.....	TBr	Version 2	2004-11-19
Geprüft / checked	Kontrolliert / approved	TBr	Version 1	2004-06-04
		Name	Änderung / modification	Datum / date

Würth Elektronik eiSos GmbH & Co.KG

D-74638 Waldenburg · Max-Eyth-Straße 1 - 3 · Germany · Telefon (+49) (0) 7942 - 945 - 0 · Telefax (+49) (0) 7942 - 945 - 400
<http://www.we-online.com>

Spezifikation für Freigabe / specification for release

Kunde / customer :
 Artikelnummer / part number : **749013040**
 Bezeichnung : **LAN-Übertrager WE-LAN**
 description : **LAN-Transformer WE-LAN**



DATUM / DATE : 2011-01-10

I Rollenspezifikation / tape and reel specification :

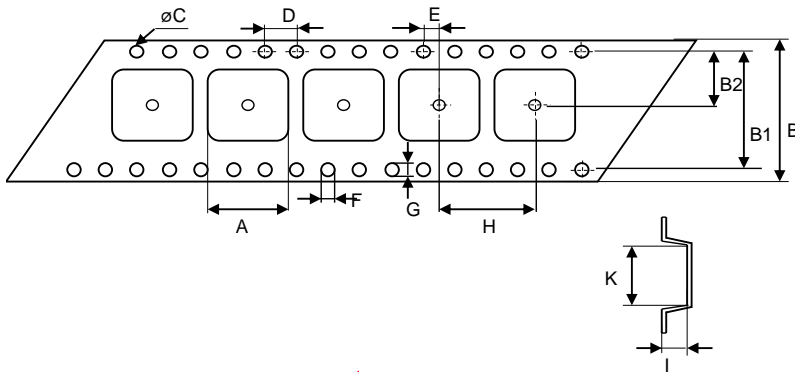

Gurtspezifikation / Tape specification:

A	16,1 ± 0,1	mm
B	44,0 ± 0,3	mm
B1	40,4 ± 0,1	mm
B2	20,2 ± 0,1	mm
C	1,50 ^{+0,1} - 0,0	mm
D	4,00 ± 0,1	mm
E	2,00 ± 0,1	mm
F	1,50 ^{+0,1} - 0,0	mm
G	1,70 ^{+0,15} - 0,05	mm
H	24,0 ± 0,1	mm
I	7,4 ± 0,1	mm
K	28,2 ± 0,1	mm

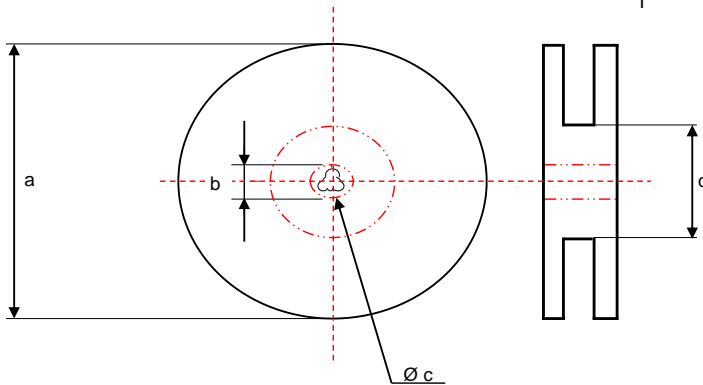

Rollenspezifikation / Reel specification:

a	330,0 ± 2,0	mm
b	21,00 ± 0,8	mm
c	13,50 ± 0,5	mm
d	100,0 ± 1,0	mm

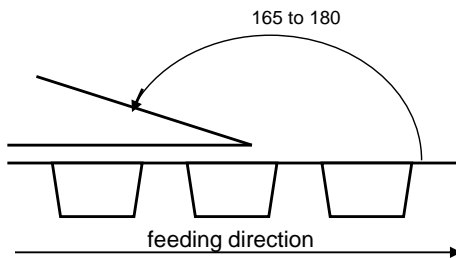

The force for tearing off cover tape is 10 to 130 grams in arrow direction

Freigabe erteilt / general release:	Kunde / customer			
.....				
Datum / date	Unterschrift / signature	Mle	Version 4	2012-01-10
.....	Würth Elektronik	TBr	Version 3	2005-07-15
.....	TBr	Version 2	2004-11-19
Geprüft / checked	Kontrolliert / approved	TBr	Version 1	2004-06-04
		Name	Änderung / modification	Datum / date

This electronic component has been designed and developed for usage in general electronic equipment. Before incorporating this component into any equipment where higher safety and reliability is especially required or if there is the possibility of direct damage or injury to human body, for example in the range of aerospace, aviation, nuclear control, submarine, transportation, (automotive control, train control, ship control), transportation signal, disaster prevention, medical, public information network etc, Würth Elektronik eiSos GmbH must be informed before the design-in stage. In addition, sufficient reliability evaluation checks for safety must be performed on every electronic component which is used in electrical circuits that require high safety and reliability functions or performance.

Würth Elektronik eiSos GmbH & Co.KG

D-74638 Waldenburg · Max-Eyth-Straße 1 - 3 · Germany · Telefon (+49) (0) 7942 - 945 - 0 · Telefax (+49) (0) 7942 - 945 - 400
<http://www.we-online.com>