

Transition Socket Specification

SOT/DFN/QFN TRANSITION SOCKETS

SOT/DFN/QFN transition sockets and associated hardware are shown below.

FIGURE 7: SOT TRANSITION SOCKET WITH CABLE

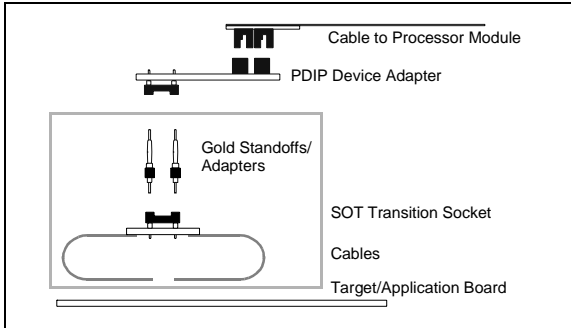

FIGURE 8: DFN/QFN TWO-PART TRANSITION SOCKET

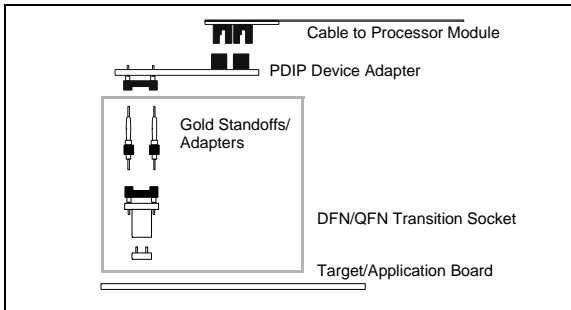

FIGURE 9: QFN TRANSITION SOCKET

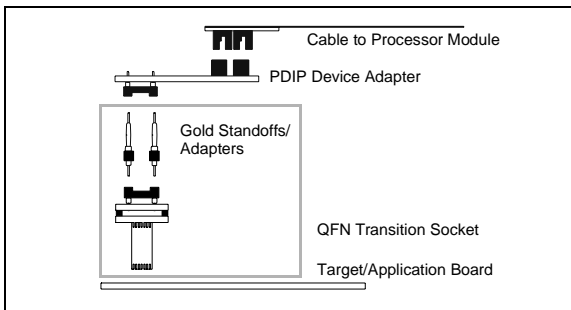

FIGURE 10: DFN TRANSITION SOCKET WITH CABLE

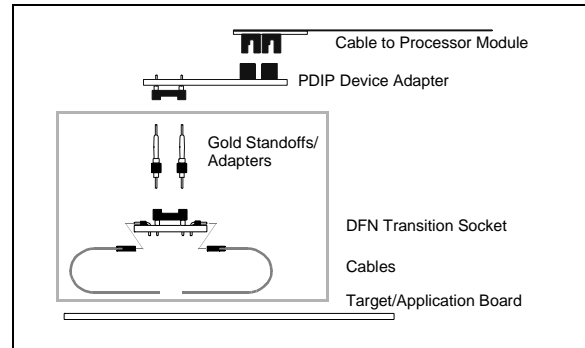
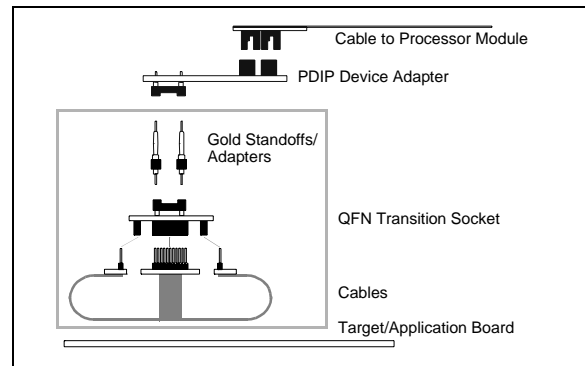

FIGURE 11: QFN TRANSITION SOCKET WITH CABLE



Microchip offers the following SOT/DFN/QFN transition sockets:

- XLT06SOT: One 6-lead SOT transition socket with cable
- XLT08DFN: One 8-lead DFN two-part transition socket
- XLT08DFN2: One 8-lead DFN transition socket with cable
- XLT16QFN1: One 16-lead QFN transition socket with cable
- XLT28QFN3: One 28-lead QFN transition socket with cable
- XLT28QFN4: One 28-lead QFN transition socket with cable
- XLT44QFN2: One 44-lead QFN transition socket with cable
- XLT44QFN3: One 44-lead QFN transition socket with cable

The following sockets have been discontinued:

- XLT28QFN: One 28-lead QFN transition socket. (Replaced by XLT28QFN4.)
- XLT28QFN2: One 28-lead QFN transition socket. (Replaced by XLT28QFN3.)
- XLT44QFN: One 44-lead QFN two-part transition socket. (Replaced by XLT44QFN2.)

See the drawings in this section for layout dimensions.

Transition Socket Specification

RECOMMENDED INSTALLATION OF TRANSITION SOCKETS WITH CABLES

For transition sockets that use a cable, follow these instructions for installing your transition socket on the target board.

PCB Layout Considerations:

Make sure you leave enough room on the PCB to accommodate the cable, i.e., space your target pads for each device far enough apart so that the cable from one pad group will not interfere with another pad group.

6-Pin SOT Solder Instructions:

1. Remove protective cable covering from end of cable.
2. Position cables on target board (see below). Tape down to prevent movement.
3. Solder each lead to target pad.
4. Remove tape and clean.

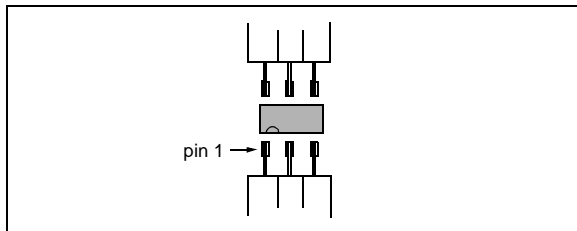

8-Pin DFN Solder Instructions:

1. Prepare leads by trimming narrowest portion to 0.10-inch maximum in length (see below).
2. Position cables on target board (see below). Tape down to prevent movement.
3. Solder each lead to target pad.
4. Remove tape and clean.

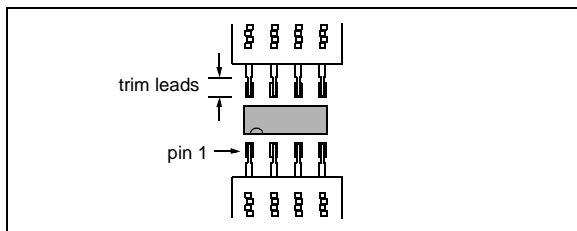

8-Pin DFN Assembly Instructions:

1. Start with cable associated with pin 1.
2. Fold cable up and over, forming a radius.
3. Mate with the header on the side of the transition socket assembly, making sure pin 1 mates with the pin labeled "DFN Pin 1".
4. Fold over and mate the other cable.

16-Pin QFN Solder Instructions:

1. Remove protective cable jacket from stripped end of cable.
2. Lay out the four cables in a "+" pattern (see below).

3. Center each cable on the footprint (see below). Tape down each cable to prevent movement.
4. Solder each lead to target pad.
5. Remove tape and clean

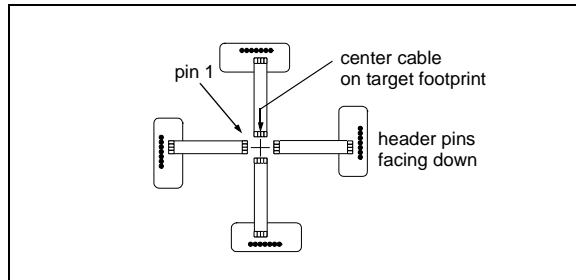

16-Pin QFN Assembly Instructions:

1. Start with cable associated with pin 1.
2. Fold cable up and over, forming a radius. Header pins will now be facing upwards.
3. Mate with the socket on the underside of the transition socket assembly, making sure pin 1 mates with the pin labeled "QFN Pin 1".
4. Fold over and mate the other cables.

28/44-Pin QFN Solder Instructions:

1. Remove protective cable jacket from stripped end of cable.
2. Lay out with long cables opposing each other and short cables opposing each other (see below).
3. Place center lead (6th lead for 44-pin, 4th lead for 28-pin) on center target pad to center each cable on the footprint (see below). Tape down each cable to prevent movement.
4. Solder each lead to target pad.
5. Remove tape and clean

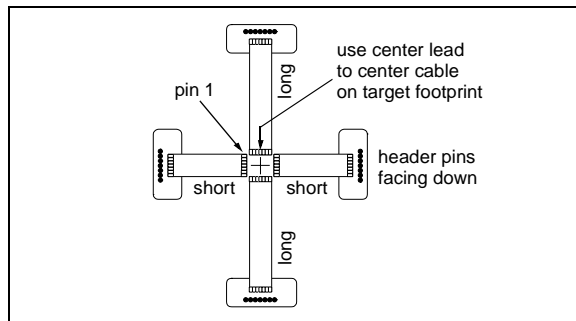

28/44-Pin QFN Assembly Instructions:

1. Start with cable associated with pin 1.
2. Fold cable up and over, forming a radius. Header pins will now be facing upwards.
3. Mate with the socket on the underside of the transition socket assembly, making sure pin 1 mates with the pin labeled "QFN Pin 1".
4. Fold over and mate the other cables.

Transition Socket Specification

RECOMMENDED PCB LAYOUT

The recommended target board footprint layout for different pin-counts is shown here.

FIGURE 12: 6-PIN SOT, 8-PIN DFN

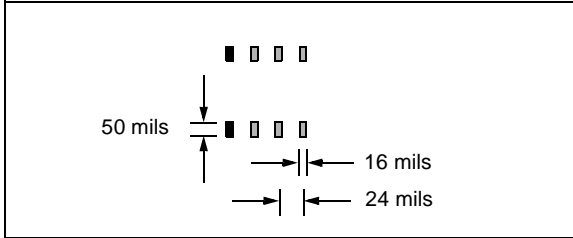

FIGURE 13: 16-PIN QFN

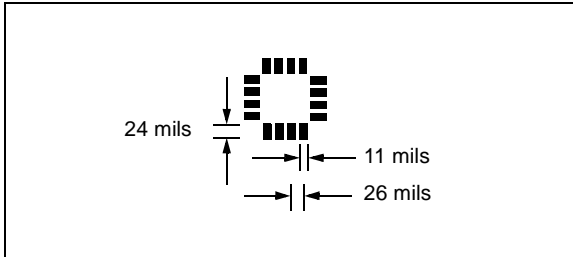

FIGURE 14: 28-PIN QFN

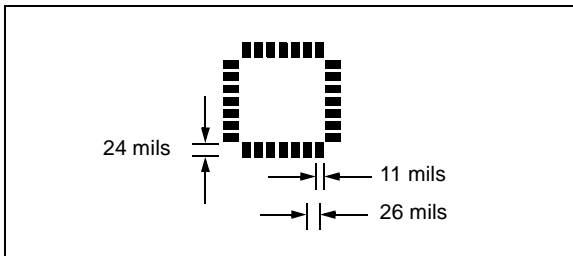
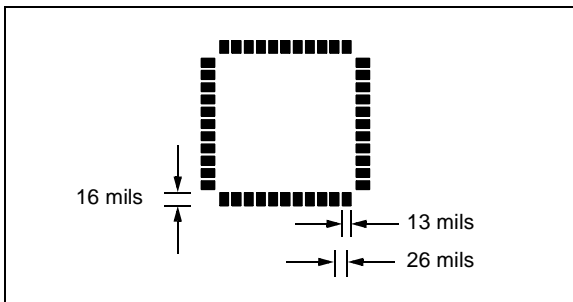
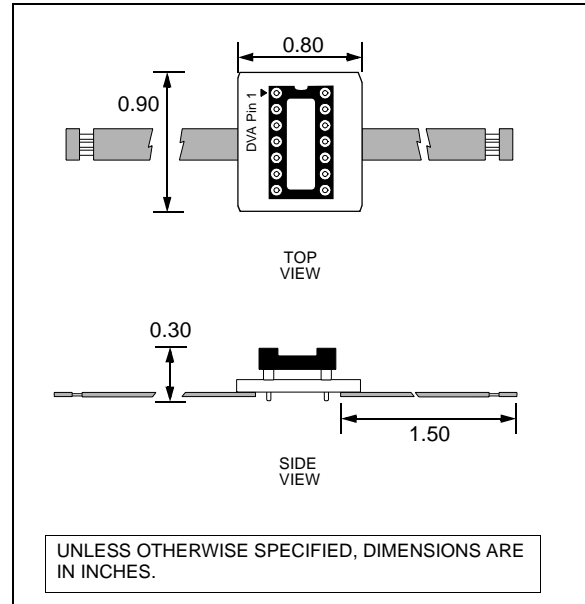

FIGURE 15: 44-PIN QFN



XLT06SOT

6-lead SOT-23 to 0.80-inch Adapter Socket



XLT08DFN2

8/14-lead DIP to 0.025-inch Adapter Socket

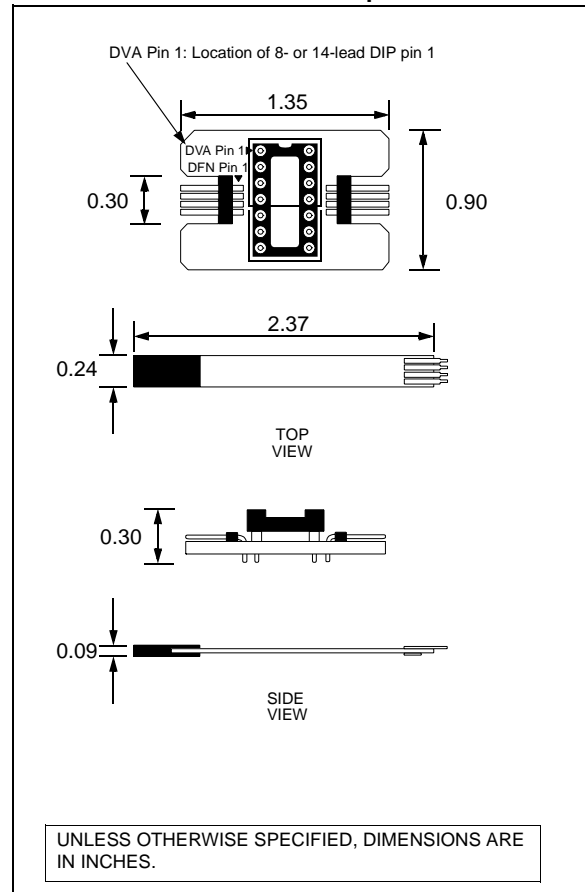

Transition Socket Specification

XLT16QFN1, XLT28QFN3, XLT28QFN4,
XLT44QFN2, XLT44QFN3

Multi-lead DIP to 0.025-inch Adapter Socket

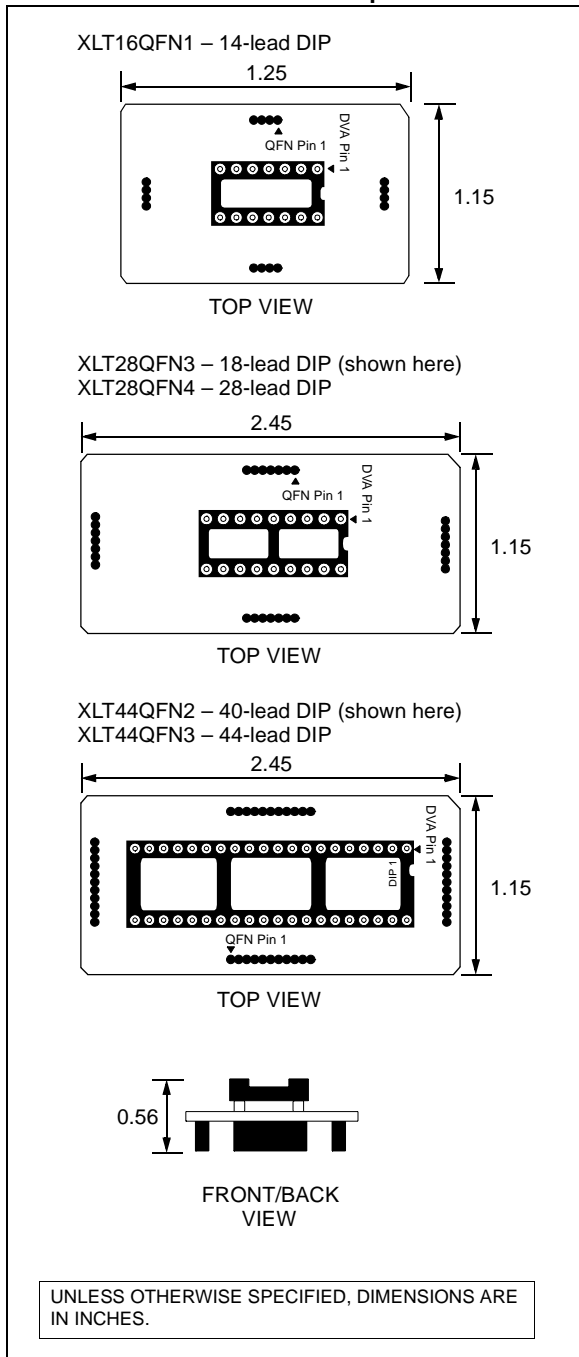

Multi-lead DIP to 0.025-inch Adapter Socket Cables

