

GPS-310FS

Fast-Acquisition Enhanced-Sensitivity 16-Channel SMD GPS Receiver Module

The GPS-31-FS is a miniature 12-channel OEM GPS receiver module. It is optimized for high-performance, ease-of-use, flexibility, and low-cost. The GPS receiver is suitable for a wide range of navigation and tracking applications.

FEATURES

- 16 parallel channel GPS receiver
- 4000+ correlators
- SBAS (WAAS, EGNOS) support
- Supports active and passive antenna
- High Sensitivity:
 - -140dBm acquisition sensitivity
 - -155dBm tracking sensitivity
- Fast Acquisition:
 - < 5 second hot start
 - < 35 seconds warm start
 - < 60 second cold start
- 5m CEP accuracy
- Low Power Consumption, < 130mW
- **Small Size, 25.4 x 25.4 x 3.4 mm**

16 parallel channels and 4000+ correlators provide fast satellite signal acquisition and short start-up time. Acquisition sensitivity of -140dBm and tracking sensitivity of -155dBm offers good performance even under difficult environments.

The GPS-310FS provides one 3.3V UART serial I/O and one GPIO pins. Self-contained LNA supports direct connection to passive or active antenna.

Sub-100mW power consumption makes the GPS-310FS ideal for battery-operated portable devices.

Satellite-based augmentation systems, such as WAAS and EGNOS, are supported to yield improved accuracy.

Small size and SMD mounting allow standard SMT assembly process, making it ideal for high volume production.

Ordering Information

Part Number	Description
GPS-310FS	Embedded GPS Module, 16 Channel

TECHNICAL SPECIFICATIONS

Receiver Type	16 parallel channel, L1 C/A code
Accuracy	Position 5m CEP Velocity 0.1m/sec 1PPS Timing +/- 1uS
Startup Time	< 5sec hot start < 35sec warm start < 60sec cold start
Signal Reacquisition	1s
Sensitivity	-143dBm acquisition -155dBm tracking
Update Rate	1Hz
Dynamics	4G (39.2m/sec ²)
Operational Limits	Altitude < 18,000m or velocity < 515m/s (COCOM limit, either may be exceeded but not both)
Serial Interface	LVTTL level
Protocol	NMEA-0183 V3.01 GPGGA, GPGLL, GPGSA, GPGSV, GPRMC, GPVTG, GPZDA 4800, 9600, 19200, 38400 baud, 8, N, 1 (default is 4800)
Datum	Default WGS-84
Input Voltage	3.3V DC +/-10%
Current Consumption	45mA
Weight:	3g
Operating Temperature	-40°C ~ +85°C
Humidity	5% ~ 95%

BLOCK DIAGRAM – LS-41SMD-R (GPS-310FS)

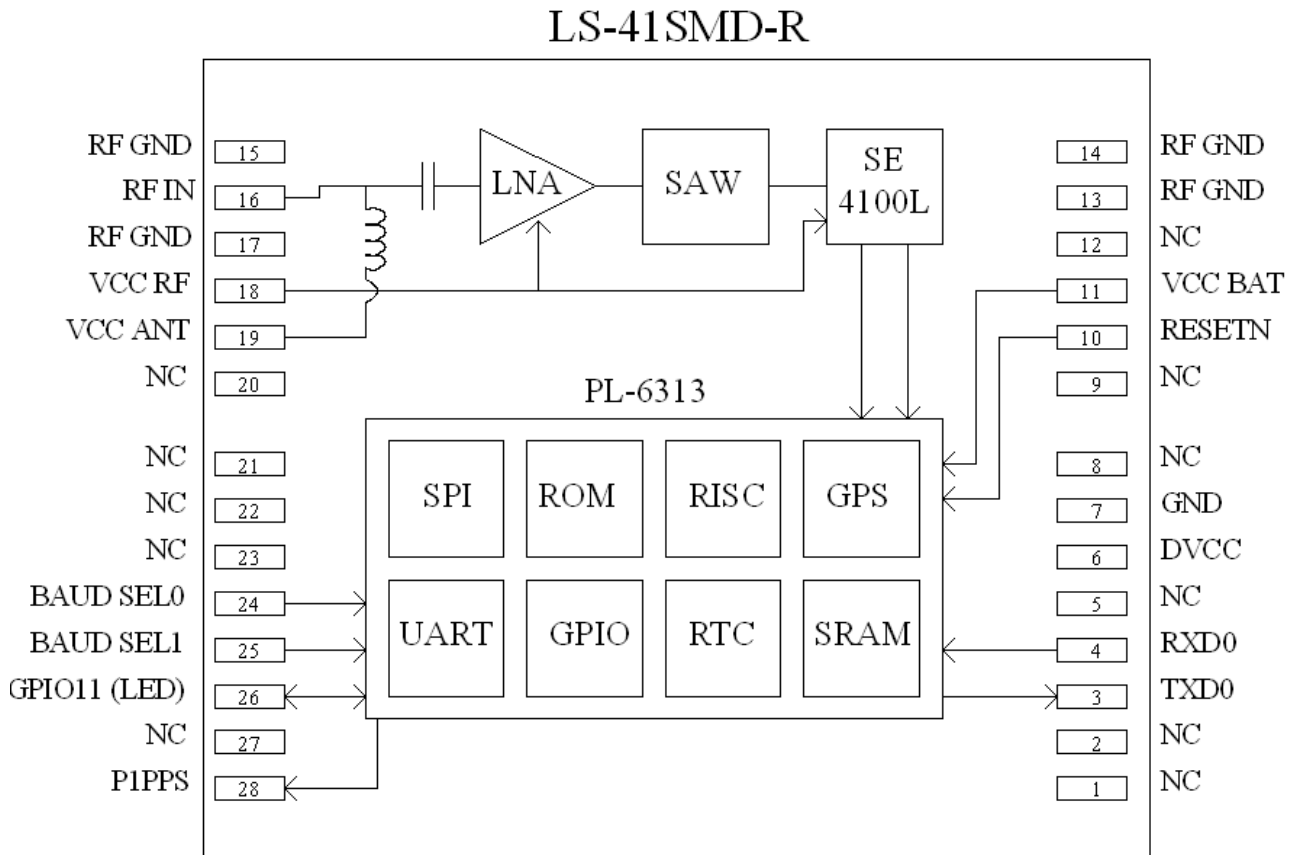

PINOUT DESCRIPTION

Pin Number	Signal Name	I/O	Description
1	NC	-	No connection
2	NC	-	No connection
3	TXD0	O	3.3V LVTTTL async serial output, to output NMEA message
4	RXD0	I	3.3V LVTTTL async serial input, to input binary commands
5	NC	-	No connection
6	DVCC	-	Regulated 3.3V supply input for digital section
7	GND	-	Ground
8	NC	-	No connection
9	NC	-	No connection
10	RESETN	I	Manual reset input, active LOW. Leave open if not used.
11	VCC BAT	-	2.0V ~ 3.9V supply voltage to sustain RTC and SRAM data. Connect to GND if not used; will cold start every time.
12	NC	-	No connection
13	RF GND	-	RF ground
14	RF GND	-	RF ground
15	RF GND	-	RF ground
16	RF IN	I	GPS signal input. 50Ω impedance.
17	RF GND	-	RF ground
18	VCC RF	-	Regulated 3.3V supply voltage for the RF section
19	VCC ANT	-	Power input for active antenna. Leave open if not used.
20	NC	-	No connection
21	NC	-	No connection
22	NC	-	No connection
23	NC	-	No connection
24	BAUD SEL0	I	Baud rate selection 0
25	BAUD SEL1	I	Baud rate selection 1 BAUDSEL[1:0] 00 4800 baud 01 9600 baud 10 19200 baud 11 38400 baud
26	GPIO11 (LED)	O	3.3V GPIO, default used for GPS status indication
27	NC	-	No connection
28	P1PPS	O	1 pulse per second time mark

1PPS Output

The GPS receiver is in navigation mode upon power-up, with 1PPS output free running. After 3 minutes of valid position fix and remaining under static-mode, the receiver changes to timing-mode, with 1PPS output signal synchronized to the UTC second. The receiver will change to navigation-mode, with 1PPS output free running, if the receiver is in motion. The 1PPS output will become synchronized to the UTC second again after the receiver had remained in static mode for 3 minutes.

MODULE DIMENSIONS

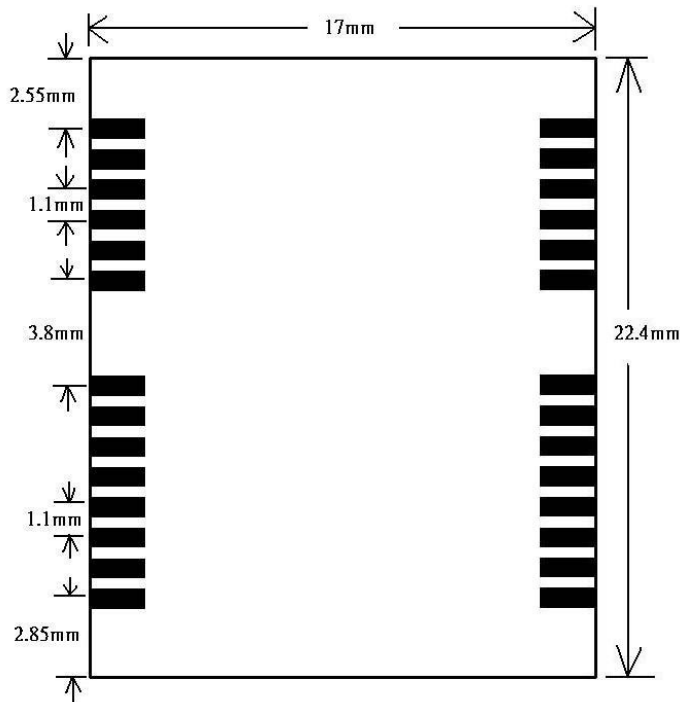

RECOMMENDED PAD LAYOUT

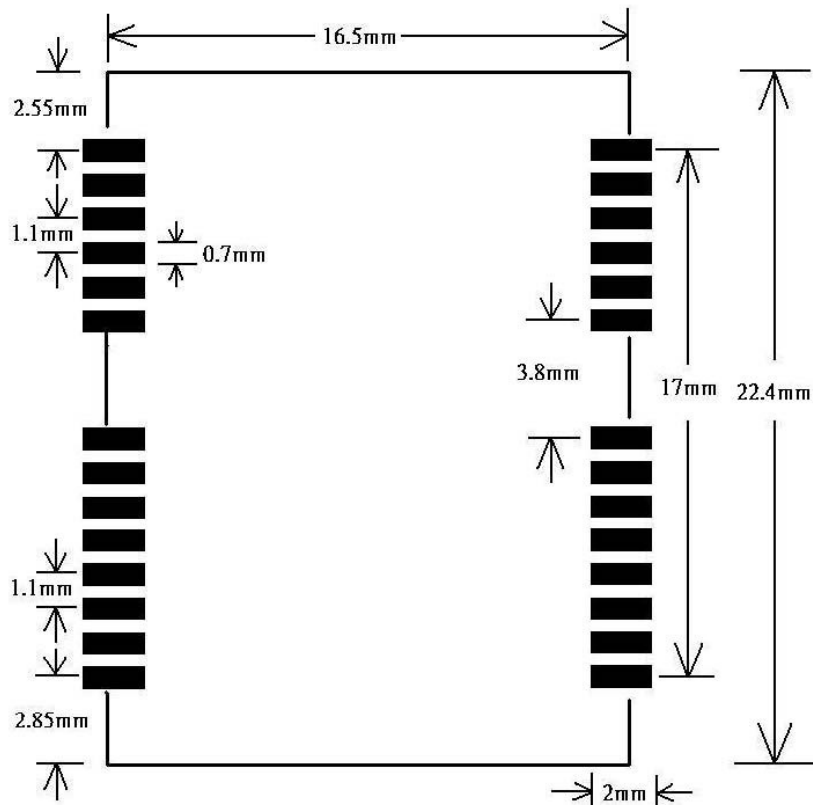

ACTIVE ANTENNA APPLICATION - - LS-41SMDR (GPS-310FS)

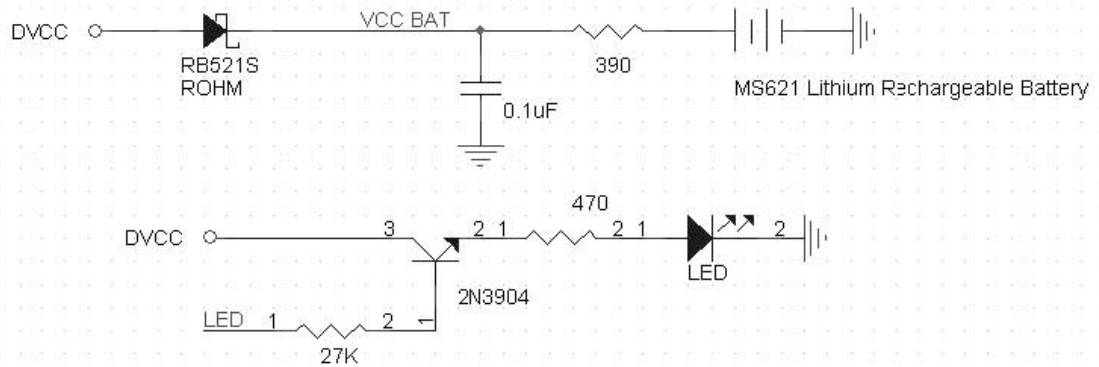
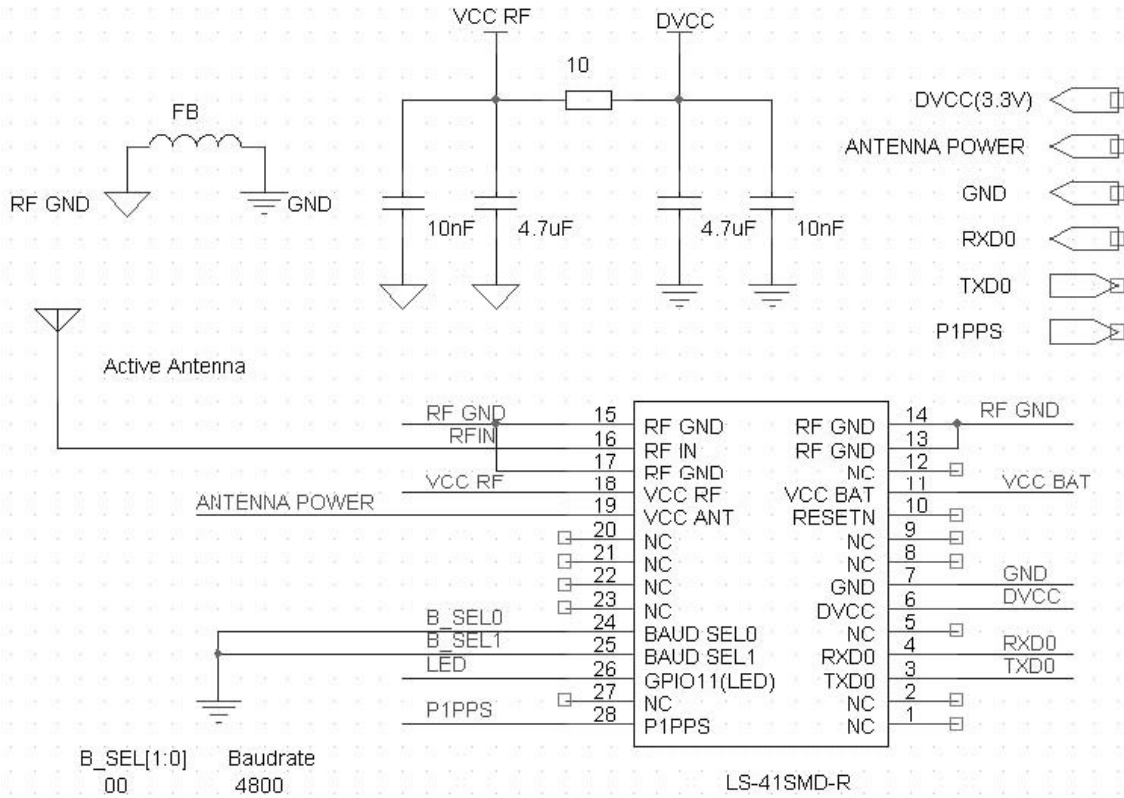

PATCH ANTENNA APPLICATION

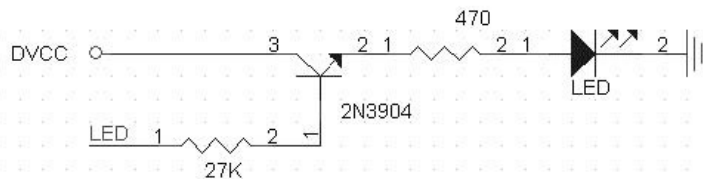
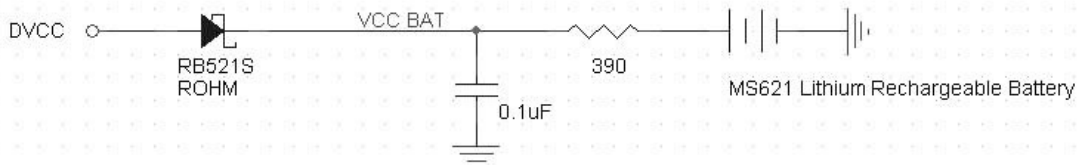
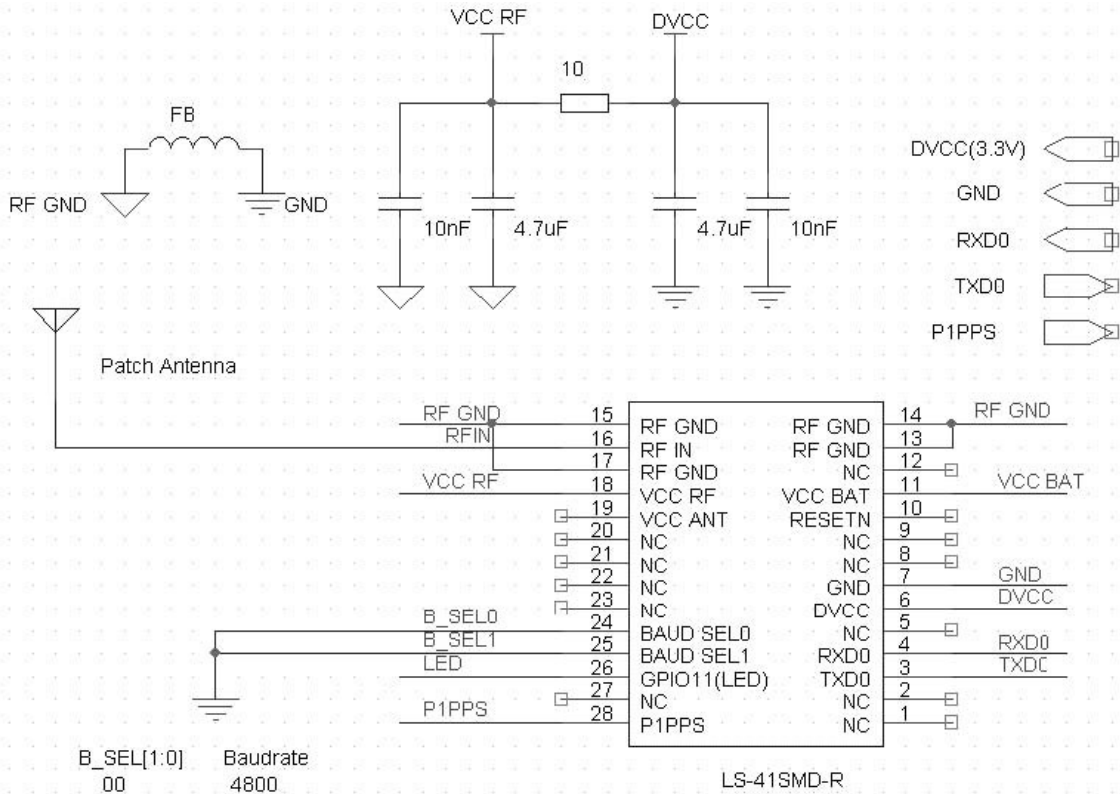

NMEA Messages

The serial interface protocol is based on the National Marine Electronics Association's NMEA 0183 ASCII interface specification. This standard is fully define in "NMEA 0183, Version 3.01" The standard may be obtained from NMEA, www.nmea.org

GGA - GPS FIX DATA

Time, position and position-fix related data (number of satellites in use, HDOP, etc.).

Format:

\$GPGGA,<1>,<2>,<3>,<4>,<5>,<6>,<7>,<8>,<9>,M,<10>,M,<11>,<12>,*<13><CR><LF>

Example:

\$GPGGA,104549.04,2447.2038,N,12100.4990,E,1,06,01.7,00078.8,M,0016.3,M,,*5C<CR><LF>

Field	Example	Description
1	104549.04	UTC time in hhmmss.ss format, 000000.00 ~ 235959.99
2	2447.2038	Latitude in ddm.mmm format Leading zeros transmitted
3	N	Latitude hemisphere indicator, 'N' = North, 'S' = South
4	12100.4990	Longitude in dddmm.mmm format Leading zeros transmitted
5	E	Longitude hemisphere indicator, 'E' = East, 'W' = West
6	1	Position fix quality indicator 0: position fix unavailable 1: valid position fix, SPS mode 2: valid position fix, differential GPS mode
7	06	Number of satellites in use, 00 ~ 12
8	01.7	Horizontal dilution of precision, 00.0 ~ 99.9
9	00078.8	Antenna height above/below mean sea level, -9999.9 ~ 17999.9
10	0016.3	Geoidal height, -999.9 ~ 9999.9
11		Age of DGPS data since last valid RTCM transmission in xxx format (seconds) NULL when DGPS not used
12		Differential reference station ID, 0000 ~ 1023 NULL when DGPS not used
13	5C	Checksum

Note: The checksum field starts with a '*' and consists of 2 characters representing a hex number. The checksum is the exclusive OR of all characters between '\$' and '*'.

GLL - LATITUDE AND LONGITUDE, WITH TIME OF POSITION FIX AND STATUS

Latitude and longitude of current position, time, and status.

Format:

\$GPGLL,<1>,<2>,<3>,<4>,<5>,<6>,<7>*<8><CR><LF>

Example:

\$GPGLL,2447.2073,N,12100.5022,E,104548.04,A,A*65<CR><LF>

Field	Example	Description
1	2447.2073	Latitude in ddmm.mmmm format Leading zeros transmitted
2	N	Latitude hemisphere indicator, 'N' = North, 'S' = South
3	12100.5022	Longitude in dddmm.mmmm format Leading zeros transmitted
4	E	Longitude hemisphere indicator, 'E' = East, 'W' = West
5	104548.04	UTC time in hhmmss.ss format, 000000.00 ~ 235959.99
6	A	Status, 'A' = valid position, 'V' = navigation receiver warning
7	A	Mode indicator 'N' = Data invalid 'A' = Autonomous 'D' = Differential 'E' = Estimated
8	65	Checksum

GSA - GPS DOP AND ACTIVE SATELLITES

GPS receiver operating mode, satellites used for navigation, and DOP values.

Format:

\$GPGSA,<1>,<2>,<3>,<3>,<3>,<3>,<3>,<3>,<3>,<3>,<3>,<3>,<3>,<3>,<4>,<5>,<6>*<7><CR><LF>

Example:

\$GPGSA,A,3,26,21,,,09,17,,,,,10.8,02.1,10.6*07<CR><LF>

Field	Example	Description
1	A	Mode, 'M' = Manual, 'A' = Automatic
2	3	Fix type, 1 = not available, 2 = 2D fix, 3 = 3D fix
3	26,21,,,09,17,,,,,	PRN number, 01 to 32, of satellite used in solution, up to 12 transmitted
4	10.8	Position dilution of precision, 00.0 to 99.9
5	02.1	Horizontal dilution of precision, 00.0 to 99.9
6	10.6	Vertical dilution of precision, 00.0 to 99.9
7	07	Checksum

GSV - GPS SATELLITE IN VIEW

Number of satellites in view, PRN number, elevation angle, azimuth angle, and C/No. Only up to four satellite details are transmitted per message. Additional satellite in view information is sent in subsequent GSV messages.

Format:

\$GPGSV,<1>,<2>,<3>,<4>,<5>,<6>,<7>,...,<4>,<5>,<6>,<7> * <8><CR><LF>

Example:

\$GPGSV,2,1,08,26,50,016,40,09,50,173,39,21,43,316,38,17,41,144,42*7C<CR><LF>
\$GPGSV,2,2,08,29,38,029,37,10,27,082,32,18,22,309,24,24,09,145,*7B<CR><LF>

Field	Example	Description
1	2	Total number of GSV messages to be transmitted
2	1	Number of current GSV message
3	08	Total number of satellites in view, 00 ~ 12
4	26	Satellite PRN number, GPS: 01 ~ 32, SBAS: 33 ~ 64 (33 = PRN120)
5	50	Satellite elevation number, 00 ~ 90 degrees
6	016	Satellite azimuth angle, 000 ~ 359 degrees
7	40	C/No, 00 ~ 99 dB Null when not tracking
8	7C	Checksum

RMC - RECOMMENDED MINIMUM SPECIFIC GPS/TRANSIT DATA

Time, date, position, course and speed data.

Format:

\$GPRMC,<1>,<2>,<3>,<4>,<5>,<6>,<7>,<8>,<9>,<10>,<11>,<12>* <13><CR><LF>

Example:

\$GPRMC,104549.04,A,2447.2038,N,12100.4990,E,016.0,221.0,250304,003.3,W,A*22<CR><LF>

Field	Example	Description
1	104549.04	UTC time in hhmmss.ss format, 000000.00 ~ 235959.99
2	A	Status, 'V' = navigation receiver warning, 'A' = valid position
3	2447.2038	Latitude in dddmm.mmmm format Leading zeros transmitted
4	N	Latitude hemisphere indicator, 'N' = North, 'S' = South
5	12100.4990	Longitude in dddmm.mmmm format Leading zeros transmitted
6	E	Longitude hemisphere indicator, 'E' = East, 'W' = West
7	016.0	Speed over ground, 000.0 ~ 999.9 knots
8	221.0	Course over ground, 000.0 ~ 359.9 degrees
9	250304	UTC date of position fix, ddmmyy format
10	003.3	Magnetic variation, 000.0 ~ 180.0 degrees
11	W	Magnetic variation direction, 'E' = East, 'W' = West
12	A	Mode indicator 'N' = Data invalid 'A' = Autonomous 'D' = Differential 'E' = Estimated
13	22	Checksum

VTG - COURSE OVER GROUND AND GROUND SPEED

Velocity is given as course over ground (COG) and speed over ground (SOG).

Format:

GPVTG,<1>,T,<2>,M,<3>,N,<4>,K,<5>* <6><CR><LF>

Example:

\$GPVTG,221.0,T,224.3,M,016.0,N,0029.6,K,A*1F<CR><LF>

Field	Example	Description
1	221.0	True course over ground, 000.0 ~ 359.9 degrees
2	224.3	Magnetic course over ground, 000.0 ~ 359.9 degrees
3	016.0	Speed over ground, 000.0 ~ 999.9 knots
4	0029.6	Speed over ground, 0000.0 ~ 1800.0 kilometers per hour
5	A	Mode indicator 'N' = Data invalid 'A' = Autonomous 'D' = Differential 'E' = Estimated
6	1F	Checksum

ZDA TIME AND DATE

Format:

\$GPZDA,<1>,<2>,<3>,<4>,<5>,<6>* <7><CR><LF>

Example:

\$GPZDA,104548.04,25,03,2004,,*6C<CR><LF>

Field	Example	Description
1	104548.04	UTC time in hhmmss.ss format, 000000.00 ~ 235959.99
2	25	UTC time: day (01 ... 31)
3	03	UTC time: month (01 ... 12)
4	2004	UTC time: year (4 digit year)
5		Local zone hour Not being output by the receiver (NULL)
6		Local zone minutes Not being output by the receiver (NULL)
7	6C	Checksum

Binary Messages

See *Binary Message Protocol User's Guide, DS-41COM* for detailed descriptions.

RF Solutions Ltd.,
Unit 21, Cliffe Industrial Estate,
South Street, Lewes, E Sussex, BN8 6JL. England
Tel +44 (0)1273 898 000 Fax +44 (0)1273 480 661

Email sales@rfsolutions.co.uk

<http://www.rfsolutions.co.uk>