

NOTES

- 1 SUITABLE CRIMP CONTACTS: SERIES HN.D
CUSTOMER DRAWING: 1105050
OUTER DIMENSIONS OF INSULATION: MAX. Ø4 MM
- 2 SUITABLE MODULE FIXING FRAME: SERIES HVS SIZE 3 TO 8
CUSTOMER DRAWING: 1103250
- 3 SUITABLE INSERTION TOOL:
CUSTOMER DRAWING: 1102855
- 4 SUITABLE EXTRACTION TOOL:
CUSTOMER DRAWING: 1102855
- 5 STANDARDS:
DIN EN 61984; DIN EN 60664-1
- 8 PACKAGING:
10 SETS IN A CARTON, PRE-MOUNTED

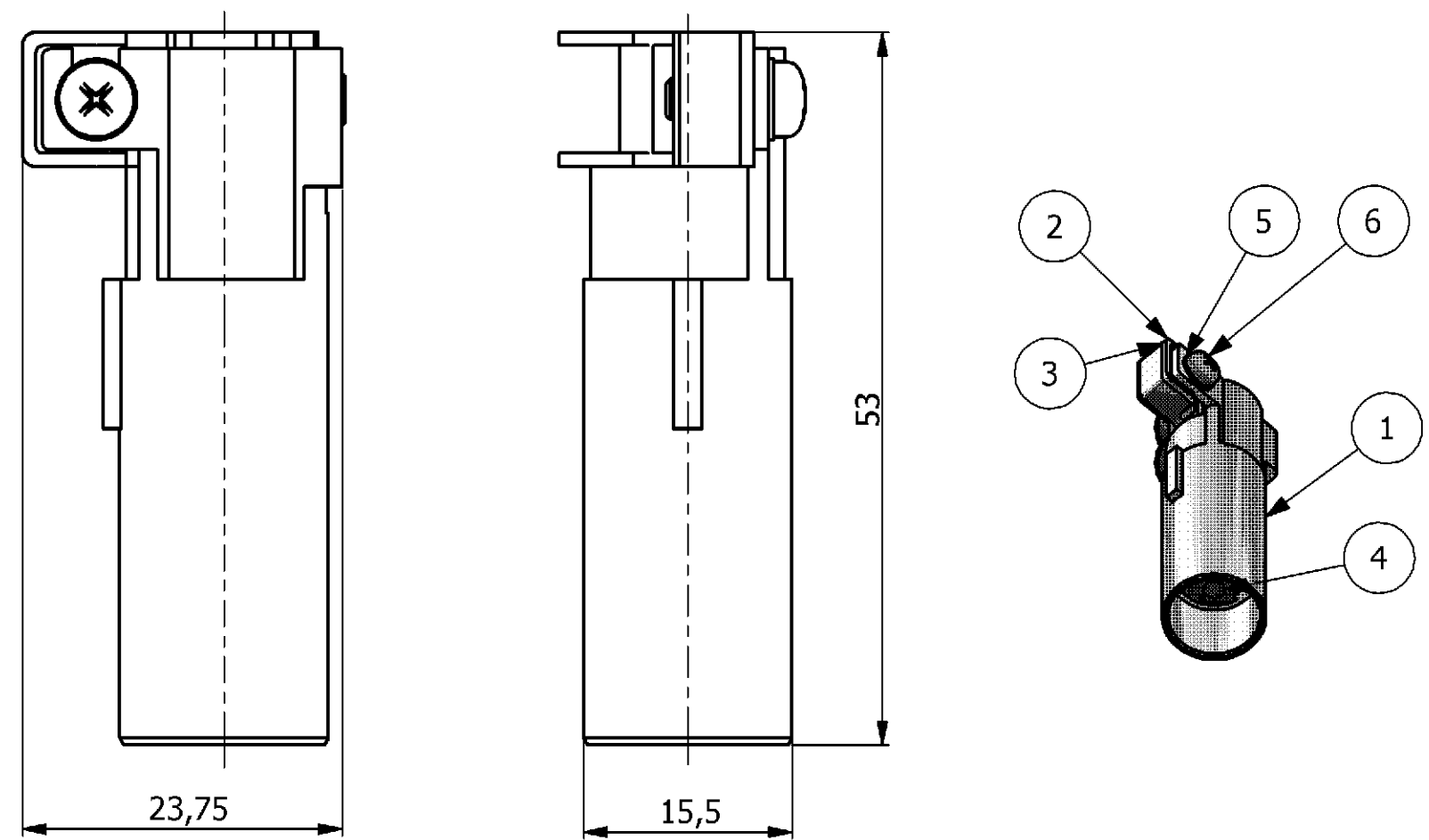

PN 0-1 as shown

QTY.	DESCRIPTION	MATERIAL	SURFACE	COLOR	NOTE	ITEM
1	SCREW	STEEL	-	-	ISO 7045 A2	6
1	SPRING WASHER, A3	STEEL	ZINC PLATED	-	DIN 137	5
1	CONTACT INSERT MALE	PA6.6-GF25	-	BLACK	-	4
1	CLOSING 6-9 MM	ZINC	-	-	-	3
1	CLOSING 3-6 MM	ZINC	-	-	-	2
1	SHIELD BARREL MALE	ZINC	-	-	-	1

Contact arrangement

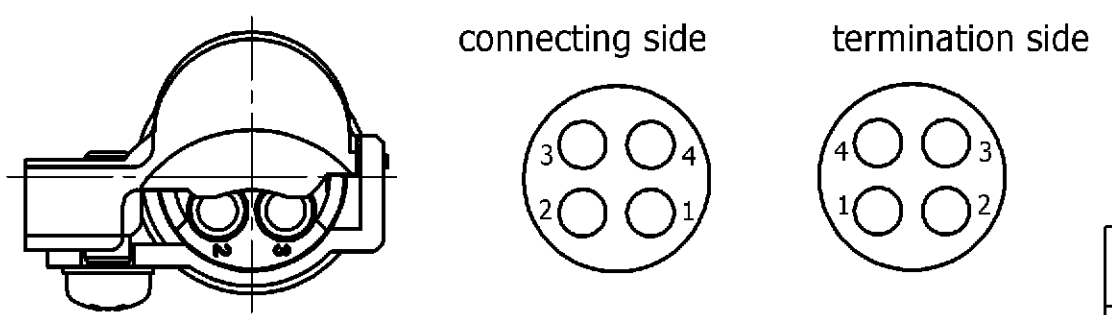

THIS DRAWING IS A CONTROLLED DOCUMENT FOR AMP INCORPORATED. IT IS SUBJECT TO CHANGE AND THE CONTROLLING ENGINEERING ORGANIZATION SHOULD BE CONTACTED FOR THE LATEST REVISION. DIESSES ZEICHNUNGSDOKUMENT WIRD DURCH AMP INCORPORATED KONTROLLIERT. ÄNDERUNGEN, DIE DEM TECHNISCHEM FORTSCHRITT DIENEN, SIND VORBEHALTEN. DEN JEWELIGS LETZTIGUELTIGEN ÄNDERUNGSSTAND ERFAHREN SIE AUF ANFRAGE.		DWN	21.02.2006	tyco Electronics	Tyco / Electronics AMP GmbH D - 53819 Neunkirchen	
DIMENSIONS: DIMENSIONEN: mm		CHK	21.02.2006			
TOLERANCES UNLESS OTHERWISE SPECIFIED: ALLGEMEINTOLERANZEN		APVD	21.02.2006	NAME SHIELD BARREL MALE HVS-TX.HND.4.STI		
n. ISO 8015 - n. ISO 2768 - mH-E n. DIN 16901- 140		PRODUCT SPEC. PRODUKTSPEZ.	108-74086			
0 PLC # 1 PLC # 2 PLC # 3 PLC # ANGLES / WINKEL #		APPLICATION SPEC. VERARBEITUNGSSPEZ.	114-74088	SIZE	CAGE CODE	DRAWING NO ZEICHNUNGS-NR.
MATERIAL		WEIGHT GEWICHT	0,001 KG	A3	00779	1103283
FINISH / OBERFLAECH / FARBE		CUSTOMER DRAWING / KUNDENZEICHNUNG		SCALE MASSSTAB	1:1	SHEET BLATT
				1	OF VON	1
				REV.	A2	

K:\Prod_Eng\3D-Modeling\1471-9\Rev12\1103283.dwg