

# DATA SHEET

2322 633 5/8....

**NTC thermistors,  
high-temperature sensors**

Product specification  
Supersedes data of 4th September 1998  
File under BCcomponents, BC02

1998 Sep 04

# NTC thermistors, high-temperature sensors

2322 633 5/8....

## FEATURES

- Small diameter
- Quick response to temperature change
- High stability over a long life
- Wide temperature range from -40 to +300 °C
- Resistant to corrosive atmospheres and harsh environments.

## APPLICATION

- High temperature measurement control:
  - Domestic appliances
  - Automotive systems
  - Industrial process control.

## DESCRIPTION

These thermistors have a negative temperature coefficient and are mounted in a glass envelope:

2322 633 5.... (SOD80) without leads and suitable for surface mounting

2322 633 8.... (SOD27) with tinned copper-clad iron leads.

## MECHANICAL DATA

### Marking

None.

### Mounting

By soldering (633 5...., 633 8....).

## QUICK REFERENCE DATA

PARAMETER	VALUE
Temperature range:	
2322 633 5....	-40 to +200 °C
2322 633 8....	-40 to +200 °C
Resistance value at 25 °C (R <sub>25</sub> )	10 to 100 kΩ
Tolerance on R <sub>25</sub> -value	±5% and ±10%
B <sub>25/85</sub> -value	3977 K
Tolerance on B <sub>25/85</sub> -value	±1.3%
Rated dissipation	100 mW
Dissipation factor	2.5 mW/K
Response time	0.9 s
Thermal time constant τ	6 s
Temperature coefficient at 25 °C	-4.38%/K
Climatic category:	
2322 633 5....	40/155/56
2322 633 8....	40/200/56
Mass:	
2322 633 5....	≈0.03 g
2322 633 8....	≈0.14 g

# NTC thermistors, high-temperature sensors

## 2322 633 5/8....

### Outlines

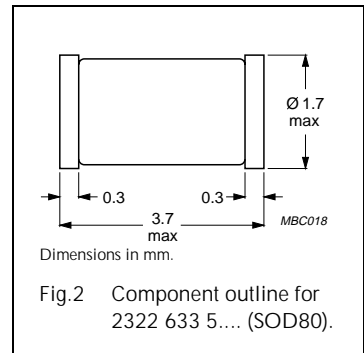
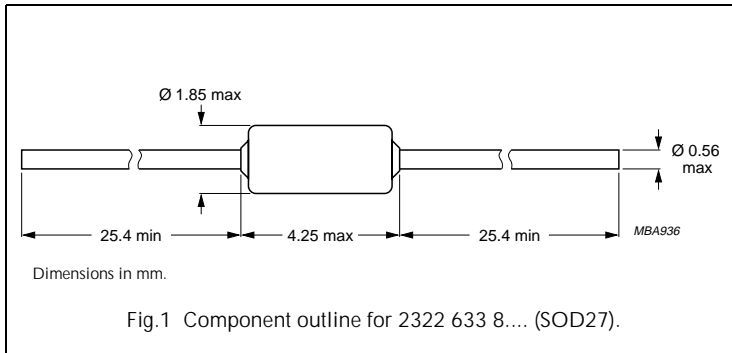

### ORDERING INFORMATION

**Table 1** Catalogue numbers and packaging quantities

CATALOGUE NUMBER	BULK	BLISTER	TAPE
2322 633 3....; note 1	–	–	10000
2322 633 5....	–	2500	–
2322 633 8....	1000	–	–

### Notes

- Catalogue number 2322 633 3.... is the series 2322 633 8.... on tape.

**Table 2**  $R_{25}$ -values,  $B_{25/85}$ -values and catalogue numbers

The thermistors have a 12-digit catalogue number starting with 2322 633 5..../8....; the subsequent 4 digits indicate the resistance value and tolerance.

$R_{25}$ (k $\Omega$ )	$B_{25/85}$ -VALUE	CATALOGUE NUMBER 2322 633 .....			
		SOD27 (leaded)		SOD80 (SMD) <sup>(1)</sup>	
		8.... tinned-copper		5....	
		$R_{25} \pm 10\%$	$R_{25} \pm 5\%$	$R_{25} \pm 10\%$	$R_{25} \pm 5\%$
10	3977 K $\pm 1.3\%$	2103	3103	2103	3103
20	3977 K $\pm 1.3\%$	2203	3203	2203	3203
30	3977 K $\pm 1.3\%$	2303	3303	2303	3303
100	3977 K $\pm 1.3\%$	2104	3104	2104	3104

### Note

- Only available in blister tape.

# NTC thermistors, high-temperature sensors

## 2322 633 5/8....

**Table 3** Resistance values at intermediate temperatures for 2322 633 5.... series

T <sub>oper</sub> (°C)	R <sub>T</sub> /R <sub>25</sub>	ΔR DUE TO B-TOLERANCE (%)	TC (%/K)	R <sub>25</sub> (kΩ)			
				2322 633 ..... (see Table 4, note 1)			
				5.103	5.203	5.303	5.104
-40	33.06	4.65	6.59	330.6	661.2	991.8	3306
-35	23.90	4.21	6.37	239.0	478.1	717.1	2390
-30	17.47	3.79	6.16	174.7	349.4	524.1	1747
-25	12.90	3.38	5.96	129.0	258.0	387.0	1290
-20	9.621	2.99	5.77	96.21	192.4	288.6	962.1
-15	7.242	2.61	5.59	72.42	144.8	217.3	724.2
-10	5.501	2.24	5.41	55.01	110.0	165.0	550.1
-5	4.214	1.89	5.24	42.14	84.28	126.4	421.4
0	3.255	1.55	5.08	32.55	65.09	97.64	325.5
5	2.534	1.22	4.93	25.34	50.67	76.01	253.4
10	1.987	0.90	4.78	19.87	39.74	59.62	198.7
15	1.570	0.59	4.64	15.70	31.40	47.10	157.0
20	1.249	0.29	4.51	12.49	24.98	37.46	124.9
25	1.000	0.00	4.38	10.00	20.00	30.00	100.0
30	0.8059	0.28	4.25	8.059	16.12	24.18	80.59
35	0.6534	0.55	4.13	6.534	13.07	19.60	65.34
40	0.5329	0.82	4.02	5.329	10.66	15.99	53.29
45	0.4371	1.08	3.91	4.371	8.742	13.11	43.71
50	0.3604	1.34	3.80	3.604	7.209	10.81	36.04
55	0.2988	1.58	3.70	2.988	5.976	8.963	29.88
60	0.2489	1.82	3.60	2.489	4.978	7.467	24.89
65	0.2084	2.06	3.51	2.084	4.168	6.251	20.84
70	0.1753	2.29	3.42	1.753	3.505	5.258	17.53
75	0.1481	2.51	3.33	1.481	2.961	4.442	14.81
80	0.1256	2.73	3.24	1.256	2.512	3.769	12.56
85	0.1070	2.95	3.16	1.070	2.141	3.211	10.70
90	0.09156	3.16	3.08	0.9156	1.831	2.747	9.156
95	0.07862	3.36	3.01	0.7862	1.572	2.359	7.862
100	0.06777	3.56	2.93	0.6777	1.355	2.033	6.777
105	0.05863	3.76	2.86	0.5863	1.173	1.759	5.863
110	0.05089	3.95	2.79	0.5089	1.018	1.527	5.089
115	0.04433	4.13	2.73	0.4433	0.8865	1.330	4.433
120	0.03873	4.32	2.66	0.3873	0.7747	1.162	3.873
125	0.03395	4.50	2.60	0.3395	0.6791	1.019	3.395
130	0.02985	4.67	2.54	0.2985	0.5971	0.8956	2.985
135	0.02633	4.84	2.49	0.2633	0.5265	0.7898	2.633
140	0.02328	5.01	2.43	0.2328	0.4656	0.6984	2.328
145	0.02065	5.17	2.38	0.2065	0.4129	0.6194	2.065
150	0.01836	5.33	2.32	0.1836	0.3671	0.5507	1.836

# NTC thermistors, high-temperature sensors

## 2322 633 5/8....

**Table 4** Resistance values at intermediate temperatures for 2322 633 8.... series

T <sub>oper</sub> (°C)	R <sub>T</sub> /R <sub>25</sub>	ΔR DUE TO B-TOLERANCE (%)	TC (%/K)	R <sub>25</sub> (kΩ)			
				2322 633 ..... (see note 1)			
				8.103	8.203	8.303	8.104
-40	33.06	4.65	6.59	330.6	661.2	991.8	3306
-35	23.90	4.21	6.37	239.0	478.1	717.1	2390
-30	17.47	3.79	6.16	174.7	349.4	524.1	1747
-25	12.90	3.38	5.96	129.0	258.0	387.0	1290
-20	9.621	2.99	5.77	96.21	192.4	288.6	962.1
-15	7.242	2.61	5.59	72.42	144.8	217.3	724.2
-10	5.501	2.24	5.41	55.01	110.0	165.0	550.1
-5	4.214	1.89	5.24	42.14	84.28	126.4	421.4
0	3.255	1.55	5.08	32.55	65.09	97.64	325.5
5	2.534	1.22	4.93	25.34	50.67	76.01	253.4
10	1.987	0.90	4.78	19.87	39.74	59.62	198.7
15	1.570	0.59	4.64	15.70	31.40	47.10	157.0
20	1.249	0.29	4.51	12.49	24.98	37.46	124.9
25	1.000	0.00	4.38	10.00	20.00	30.00	100.0
30	0.8059	0.28	4.25	8.059	16.12	24.18	80.59
35	0.6534	0.55	4.13	6.534	13.07	19.60	65.34
40	0.5329	0.82	4.02	5.329	10.66	15.99	53.29
45	0.4371	1.08	3.91	4.371	8.742	13.11	43.71
50	0.3604	1.34	3.80	3.604	7.209	10.81	36.04
55	0.2988	1.58	3.70	2.988	5.976	8.963	29.88
60	0.2489	1.82	3.60	2.489	4.978	7.467	24.89
65	0.2084	2.06	3.51	2.084	4.168	6.251	20.84
70	0.1753	2.29	3.42	1.753	3.505	5.258	17.53
75	0.1481	2.51	3.33	1.481	2.961	4.442	14.81
80	0.1256	2.73	3.24	1.256	2.512	3.769	12.56
85	0.1070	2.95	3.16	1.070	2.141	3.211	10.70
90	0.09156	3.16	3.08	0.9156	1.831	2.747	9.156
95	0.07862	3.36	3.01	0.7862	1.572	2.359	7.862
100	0.06777	3.56	2.93	0.6777	1.355	2.033	6.777
105	0.05863	3.76	2.86	0.5863	1.173	1.759	5.863
110	0.05089	3.95	2.79	0.5089	1.018	1.527	5.089
115	0.04433	4.13	2.73	0.4433	0.8865	1.330	4.433
120	0.03873	4.32	2.66	0.3873	0.7747	1.162	3.873
125	0.03395	4.50	2.60	0.3395	0.6791	1.019	3.395
130	0.02985	4.67	2.54	0.2985	0.5971	0.8956	2.985
135	0.02633	4.84	2.49	0.2633	0.5265	0.7898	2.633

# NTC thermistors, high-temperature sensors

## 2322 633 5/8....

T <sub>oper</sub> (°C)	R <sub>T</sub> /R <sub>25</sub>	ΔR DUE TO B-TOLERANCE (%)	TC (%/K)	R <sub>25</sub> (kΩ)			
				2322 633 ..... (see note 1)			
				8.103	8.203	8.303	8.104
140	0.02328	5.01	2.43	0.2328	0.4656	0.6984	2.328
145	0.02065	5.17	2.38	0.2065	0.4129	0.6194	2.065
150	0.01836	5.33	2.32	0.1836	0.3671	0.5507	1.836
155	0.01636	5.49	2.27	0.1636	0.3273	0.4909	1.636
160	0.01455	5.65	2.23	0.1455	0.2910	0.4365	1.455
165	0.01303	5.80	2.18	0.1303	0.2606	0.3909	1.303
170	0.01169	5.95	2.14	0.1169	0.2339	0.3508	1.169
175	0.01052	6.10	2.09	0.1052	0.2104	0.3156	1.052
180	0.00948	6.24	2.05	0.09484	0.1897	0.2845	0.9484
185	0.00857	6.38	2.01	0.08569	0.1714	0.2571	0.8569
190	0.00776	6.52	1.97	0.07757	0.1551	0.2327	0.7757
195	0.00704	6.66	1.93	0.07037	0.1407	0.2111	0.7037
200	0.00640	6.79	1.89	0.06396	0.1279	0.1919	0.6396

### Note

- Replace dot in last 5-digits of catalogue number by a number according to the following list and depending on tolerance on required R<sub>25</sub>-value:
  - 3 for a tolerance of ±5%.
  - 2 for a tolerance of ±10%.

### ELECTRICAL CHARACTERISTICS

Unless otherwise stated, measurements are in accordance with "IEC publication 60539"; see also Table 2.

PARAMETER	VALUE	
	2322 633 5....	2322 633 8....
B <sub>25/85</sub> -values	3977 K	
Tolerance on B-value	±1.3%	
Ratio R <sub>T</sub> /R <sub>25</sub>	refer to Table 3	refer to Table 4
Rated dissipation	100 mW	
Deviation in resistance value due to B-tolerance	refer to Table 3	refer to Table 4
Temperature coefficient	refer to Table 3	refer to Table 4

# NTC thermistors, high-temperature sensors

**2322 633 5/8....**

## Derating

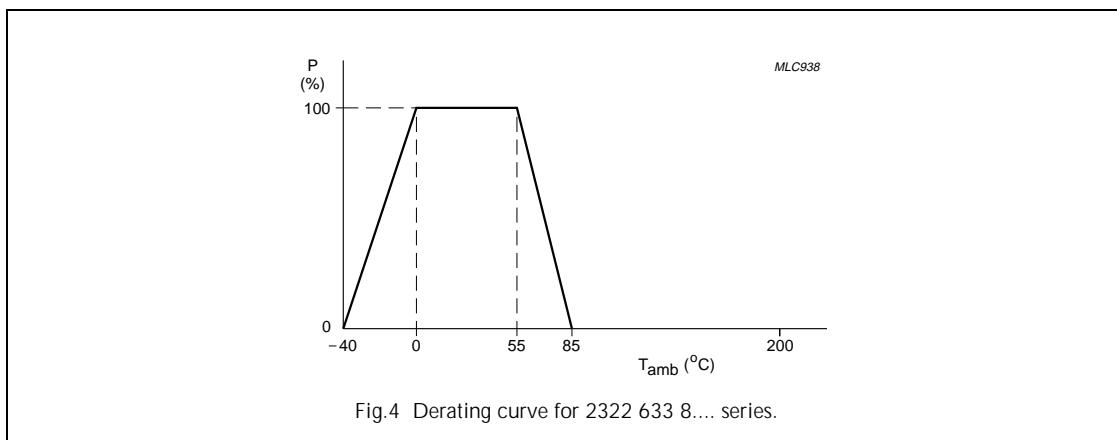
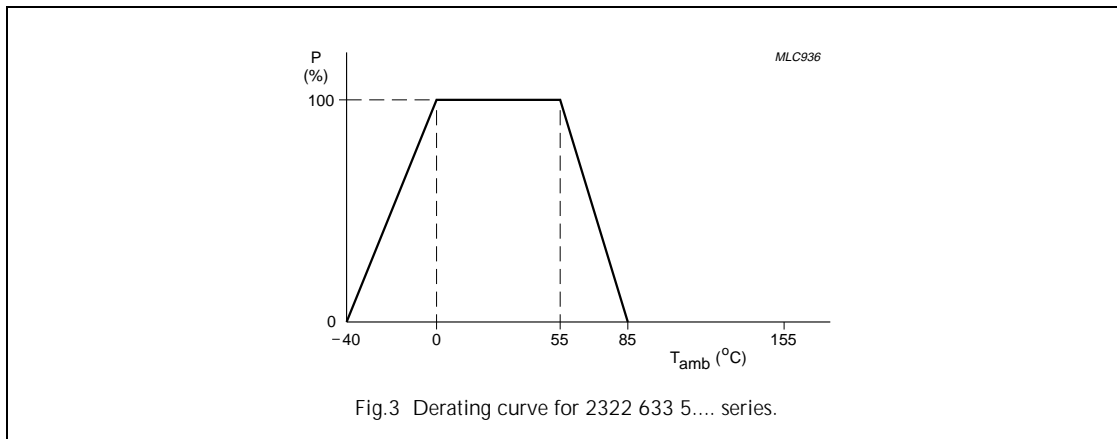

# NTC thermistors, high-temperature sensors

2322 633 5/8....

## Stability and R-T characteristics

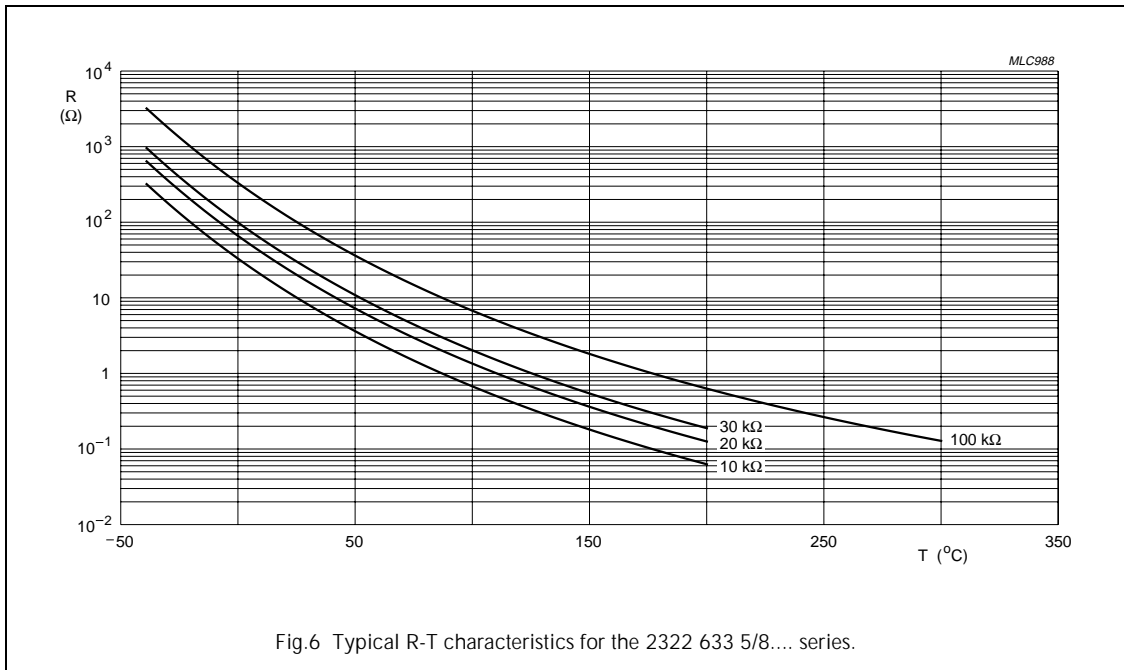
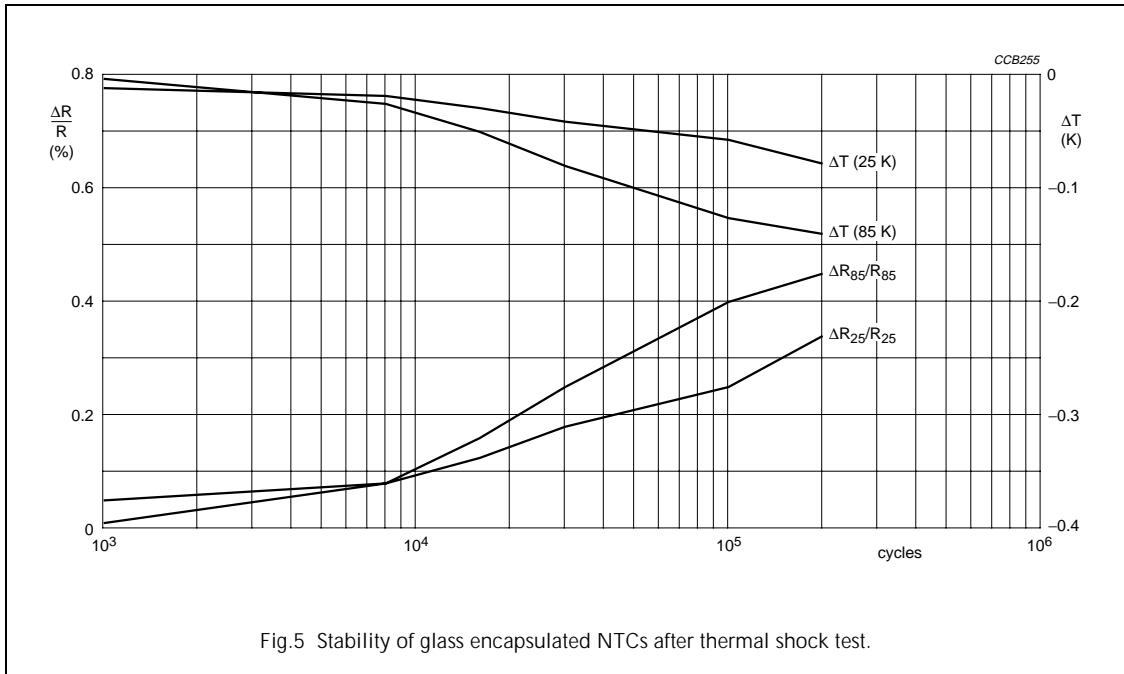



# NTC thermistors, high-temperature sensors

2322 633 5/8....

## PACKAGING

### Blister tape, reel and bandolier data

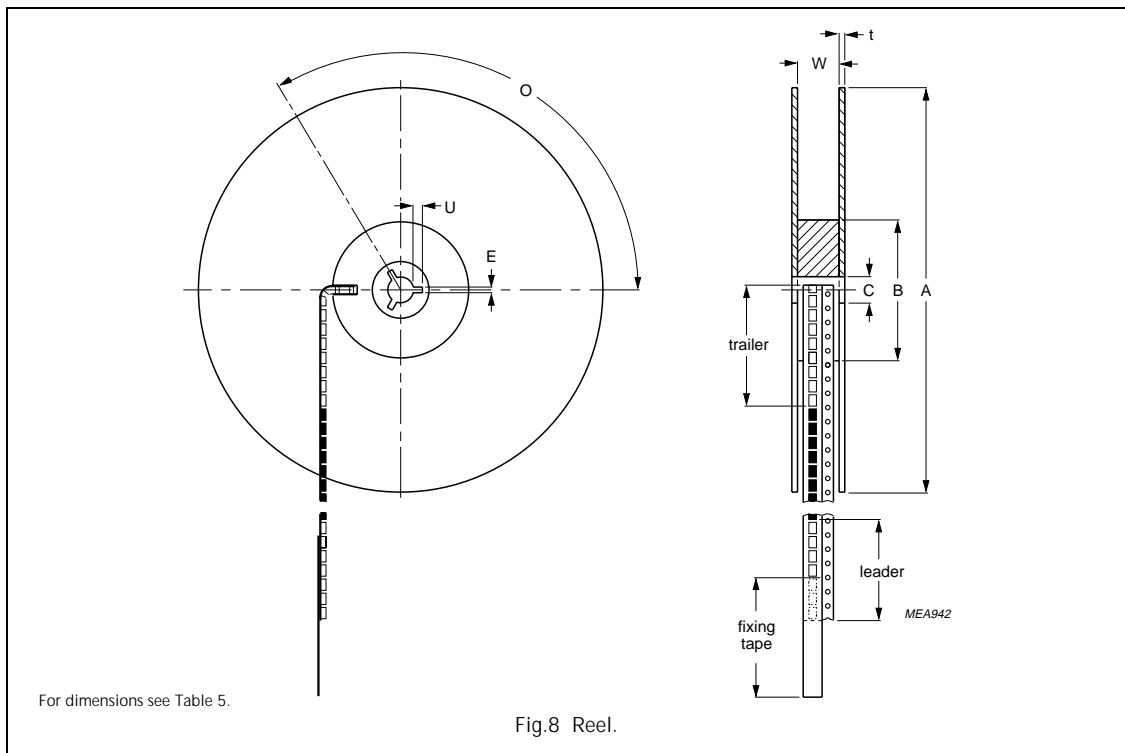
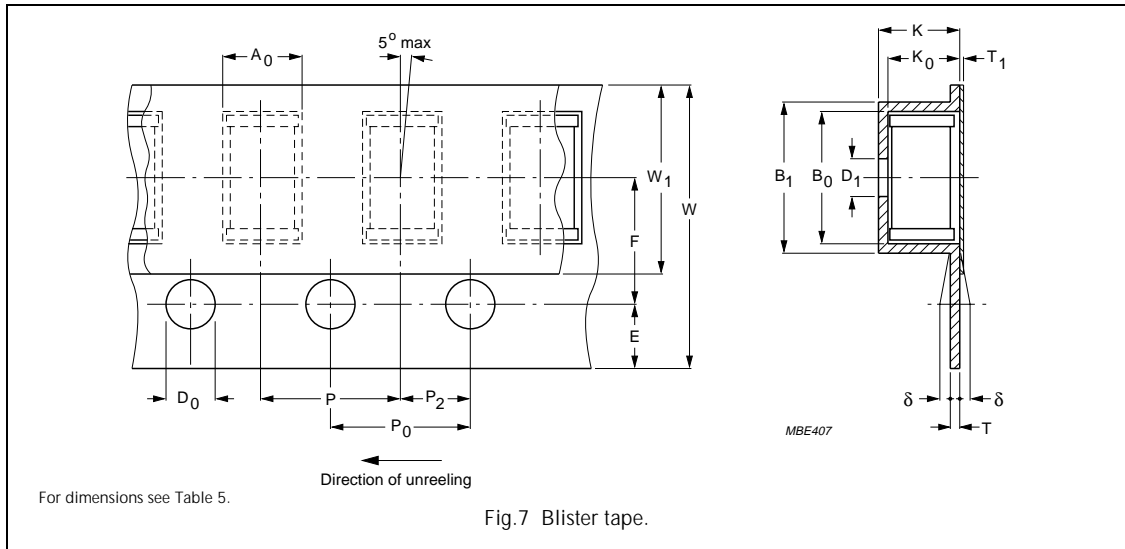

# NTC thermistors, high-temperature sensors

## 2322 633 5/8....

**Table 5** Blister tape and reel dimensions; see Figs 7 and 8

SYMBOL	PARAMETER	NOMINAL DIMENSIONS	TOLERANCE	UNIT
<b>Blister tape</b>				
K	overall thickness	<2.5	–	mm
<b>POCKET</b>				
A <sub>0</sub>	length	2.1	+0.3	mm
B <sub>0</sub>	width	>3.8	–	mm
K <sub>0</sub>	depth	2.1	+0.3	mm
B <sub>1</sub>	outside width	<4.5	–	mm
P	pitch	4.0	±0.1	mm
D <sub>1</sub>	hole diameter	1.0	±0.1	mm
<b>FEED-HOLE</b>				
D <sub>0</sub>	diameter	1.5	±0.1	mm
P <sub>0</sub>	pitch	4.0	±0.1	mm
E	distance	1.75	±0.1	mm
	cumulative pitch error over 10 positions	0	±0.1	mm
<b>CENTRE LINE</b>				
P <sub>2</sub>	length	2.0	±0.05	mm
F	width	3.5	±0.1	mm
<b>FIXING TAPE</b>				
W <sub>1</sub>	width	<5.5	–	mm
T <sub>1</sub>	thickness	<0.1	–	mm
<b>CARRIER TAPE</b>				mm
W	thickness	8.0	±0.2	mm
δ	bending	<0.3	–	mm
T	thickness	<0.4	–	mm
<b>Reel</b>				
<b>FLANGE</b>				
A	diameter	180	+0	mm
t	thickness	1.5	+0.5	mm
W	space between flanges	9.5	±0.5	mm
<b>HUB</b>				
B	diameter	62.0	±1.5	mm
C	spindle hole	12.75	+0.15/–0	mm
<b>KEY SLIT</b>				
E	width	2.0	±0.5	mm
U	depth	4.0	±0.5	mm
O	location	120	–	°

# NTC thermistors, high-temperature sensors

## 2322 633 5/8....

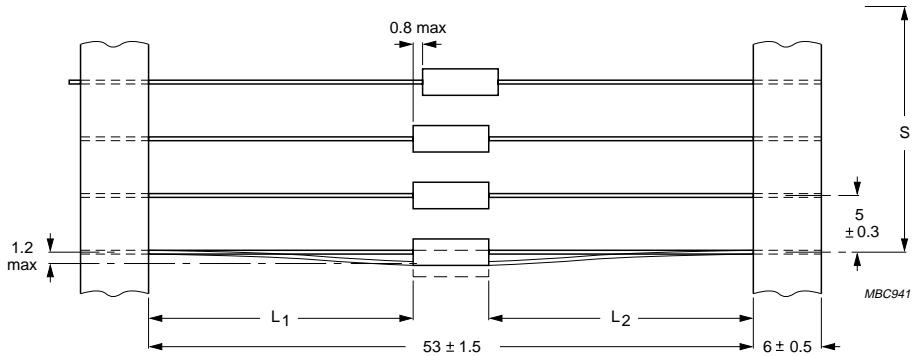

A black marker is printed on the tape of the bandolier after every 50 units.

The components are centred so that  $|L_1 - L_2| = 1.2 \text{ mm max.}$

The cumulative space (S) measured over 10 spacings =  $50 \pm 2 \text{ mm.}$

Fig.9 Thermistors on bandolier.

### Note to Table 5 and Fig.9

The bandolier of a 180 mm reel contains at least 2500 devices with no more than 0.5% empty positions.

Three consecutive empty places may be found provided this gap is followed by 6 consecutive devices.

The carrier tape starts (leader) and ends (trailer) with at least 75 empty positions (equivalent to 300 mm); the covering foil is at least 300 mm. In order to fix the carrier tape a self-adhesive tape of 20 to 50 mm width is applied.