

16-Channel, 8-Channel, Differential 8-Channel and Differential 4-Channel, CMOS Analog MUXs with Active Overvoltage Protection

The HI-506A, HI-507A, HI-508A and HI-509A are analog multiplexers with active overvoltage protection. Analog input levels may greatly exceed either power supply without damaging the device or disturbing the signal path of other channels. Active protection circuitry assures that signal fidelity is maintained even under fault conditions that would destroy other multiplexers. Analog inputs can withstand constant 70V_{P-P} levels with $\pm 15V$ supplies. Digital inputs will also sustain continuous faults up to 4V greater than either supply. In addition, signal sources are protected from short circuiting should multiplexer supply loss occur. Each input presents 1k Ω of resistance under this condition. These features make the HI-506A, HI-507A, HI-508A and HI-509A ideal for use in systems where the analog inputs originate from external equipment, or separately powered circuitry. All devices are fabricated with 44V dielectrically isolated CMOS technology. The HI-506A is a single 16-channel multiplexer, the HI-507A is an 8-channel differential multiplexer, the HI-508A is a single 8-channel multiplexer and the HI-509A is a differential 4-channel multiplexer. If input overvoltage protection is not needed the HI-506/507/508/509 multiplexers are recommended. For further information see Application Note AN520.

Features

- Analog Overvoltage 70V_{P-P}
- No Channel Interaction During Overvoltage
- Maximum Power Supply 44V
- Fail Safe with Power Loss (No Latch-Up)
- Break-Before-Make Switching
- Analog Signal Range $\pm 15V$
- Access Time. 500ns
- Power Dissipation 7.5mW
- Pb-Free Available (RoHS Compliant)

Applications

- Data Acquisition Systems
- Industrial Controls
- Telemetry

Ordering Information

PART NUMBER	PART MARKING	TEMP. RANGE (°C)	PACKAGE	PKG. DWG. #
HI1-0506A-2	HI1-506A-2	-55 to +125	28 Ld CERDIP	F28.6
HI1-0506A-5	HI1-506A-5	0 to +75	28 Ld CERDIP	F28.6
HI1-0506A-8	HI1-506A-8	-55 to +125 + 160 Hour Burn-In	28 Ld CERDIP	F28.6
HI3-0506A-5	HI3-506A-5	0 to +75	28 Ld PDIP	E28.6
HI3-0506A-5Z (Note 1)	HI3-506A-5Z	0 to +75	28 Ld PDIP (Note 2) (Pb-free)	E28.6
HI3-0507A-5	HI3-507A-5	0 to +75	28 Ld PDIP	E28.6
HI3-0507A-5Z (Note 1)	HI3-507A-5Z	0 to +75	28 Ld PDIP (Note 2) (Pb-free)	E28.6
HI1-0508A-8	HI1-508A-8	-55 to +125 + 160 Hour Burn-In	16 Ld CERDIP	F16.3
HI3-0508A-5	HI3-508A-5	0 to +75	16 Ld PDIP	E16.3
HI3-0508A-5Z (Note 1)	HI3-508A-5Z	0 to +75	16 Ld PDIP (Note 2) (Pb-free)	E16.3
HI1-0509A-2	HI1-509A-2	-55 to +125	16 Ld CERDIP	F16.3
HI1-0509A-5	HI1-509A-5	0 to +75	16 Ld CERDIP	F16.3
HI1-0509A-8	HI1-509A-8	-55 to +125 + 160 Hour Burn-In	16 Ld CERDIP	F16.3
HI3-0509A-5	HI3-509A-5	0 to +75	16 Ld PDIP	E16.3
HI3-0509A-5Z (Note 1)	HI3-509A-5Z	0 to +75	16 Ld PDIP (Note 2) (Pb-free)	E16.3

NOTES:

1. These Intersil Pb-free plastic packaged products employ special Pb-free material sets; molding compounds/die attach materials and 100% matte tin plate PLUS ANNEAL - e3 termination finish, which is RoHS compliant and compatible with both SnPb and Pb-free soldering operations. Intersil Pb-free products are MSL classified at Pb-free peak reflow temperatures that meet or exceed the Pb-free requirements of IPC/JEDEC J STD-020.
2. Pb-free PDIPs can be used for through hole wave solder processing only. They are not intended for use in Reflow solder processing applications.

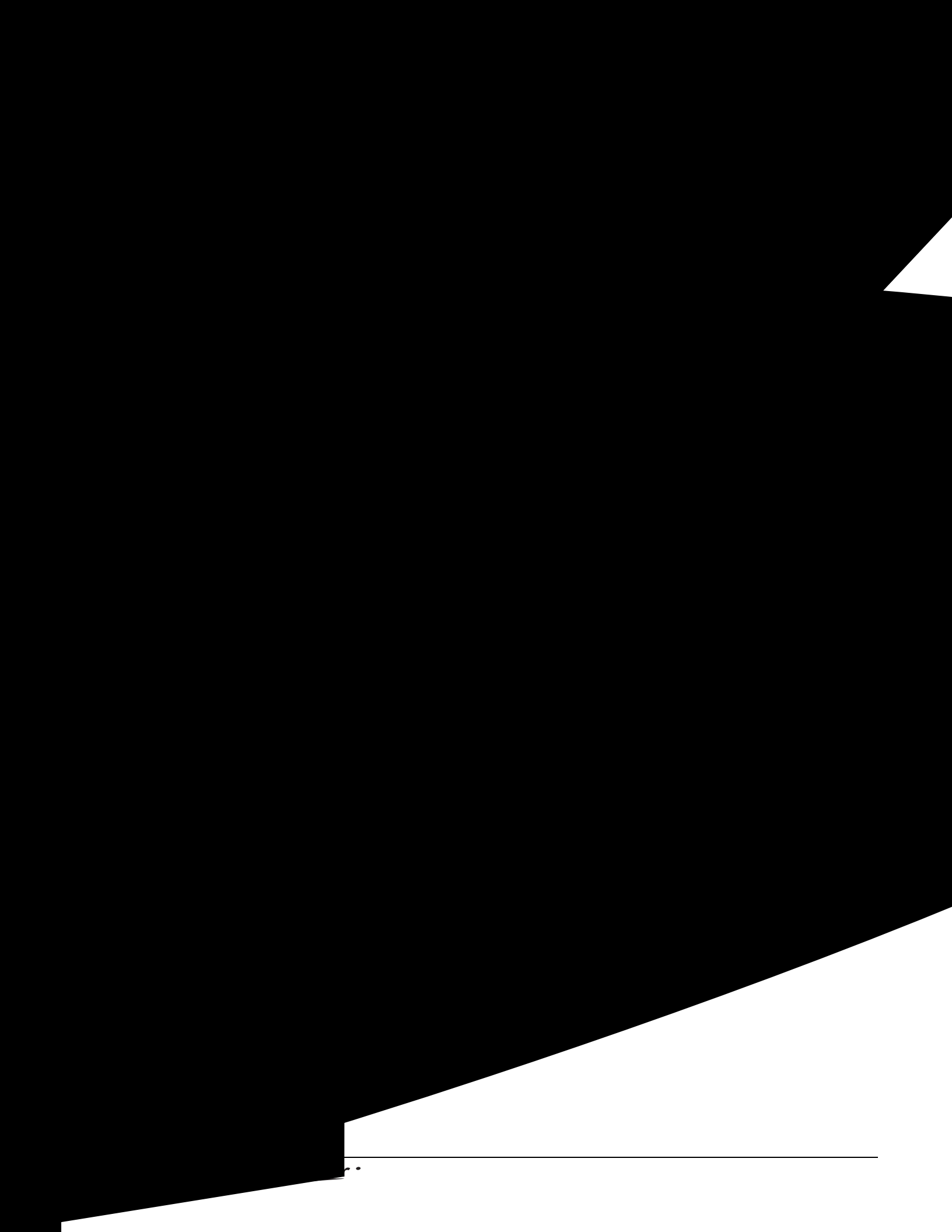

Truth Tables

HI-506A

A ₃	A ₂	A ₁	A ₀	EN	"ON" CHANNEL
X	X	X	X	L	None
L	L	L	L	H	1
L	L	L	H	H	2
L	L	H	L	H	3
L	L	H	H	H	4
L	H	L	L	H	5
L	H	L	H	H	6
L	H	H	L	H	7
L	H	H	H	H	8
H	L	L	L	H	9
H	L	L	H	H	10
H	L	H	L	H	11
H	L	H	H	H	12
H	H	L	L	H	13
H	H	L	H	H	14
H	H	H	L	H	15
H	H	H	H	H	16

HI-508A

A ₂	A ₁	A ₀	EN	"ON" CHANNEL
X	X	X	L	None
L	L	L	H	1
L	L	H	H	2
L	H	L	H	3
L	H	H	H	4
H	L	L	H	5
H	L	H	H	6
H	H	L	H	7
H	H	H	H	8

HI-509A

A ₁	A ₀	EN	"ON" CHANNEL PAIR
X	X	L	None
L	L	H	1
L	H	H	2
H	L	H	3
H	H	H	4

HI-507A

A ₂	A ₁	A ₀	EN	"ON" CHANNEL PAIR
X	X	X	L	None
L	L	L	H	1
L	L	H	H	2
L	H	L	H	3
L	H	H	H	4
H	L	L	H	5
H	L	H	H	6
H	H	L	H	7
H	H	H	H	8

Functional Diagrams

HI-506A

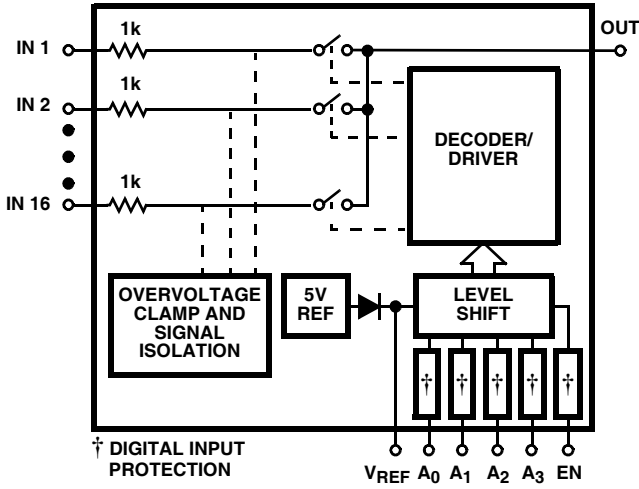

HI-507A

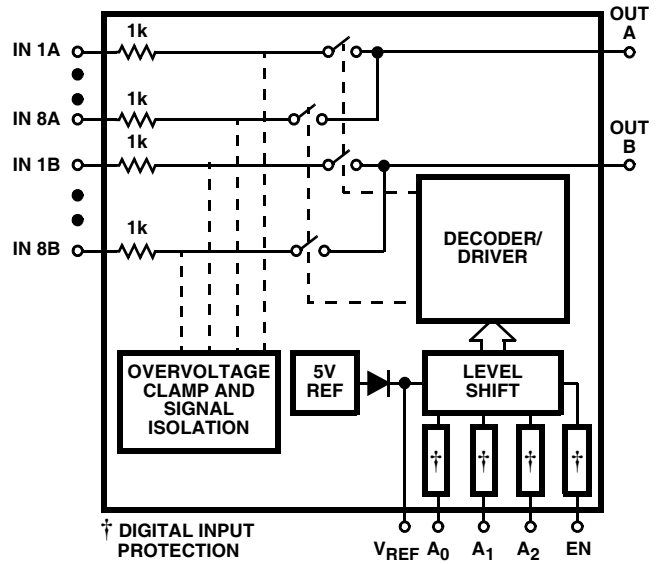

HI-508A

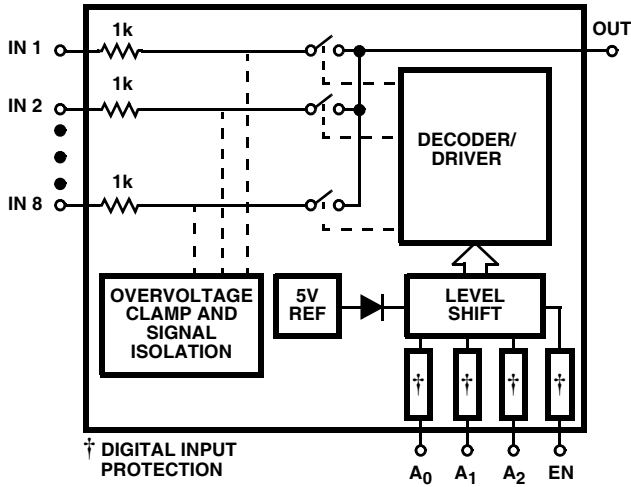

HI-509A

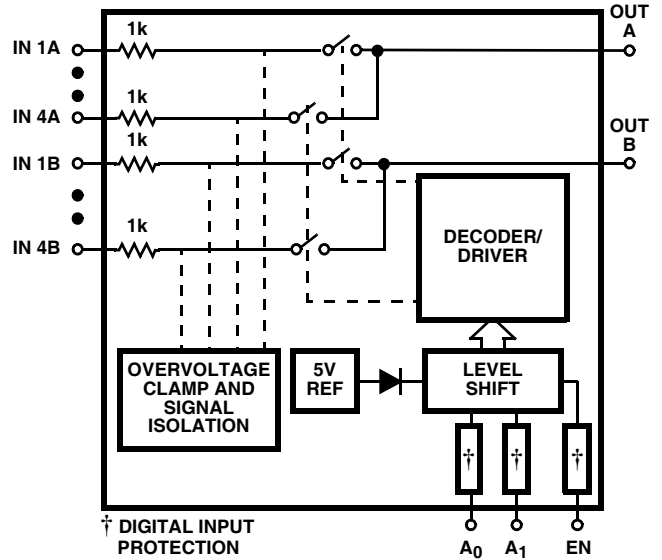

Schematic Diagrams

ADDRESS INPUT BUFFER AND LEVEL SHIFTER

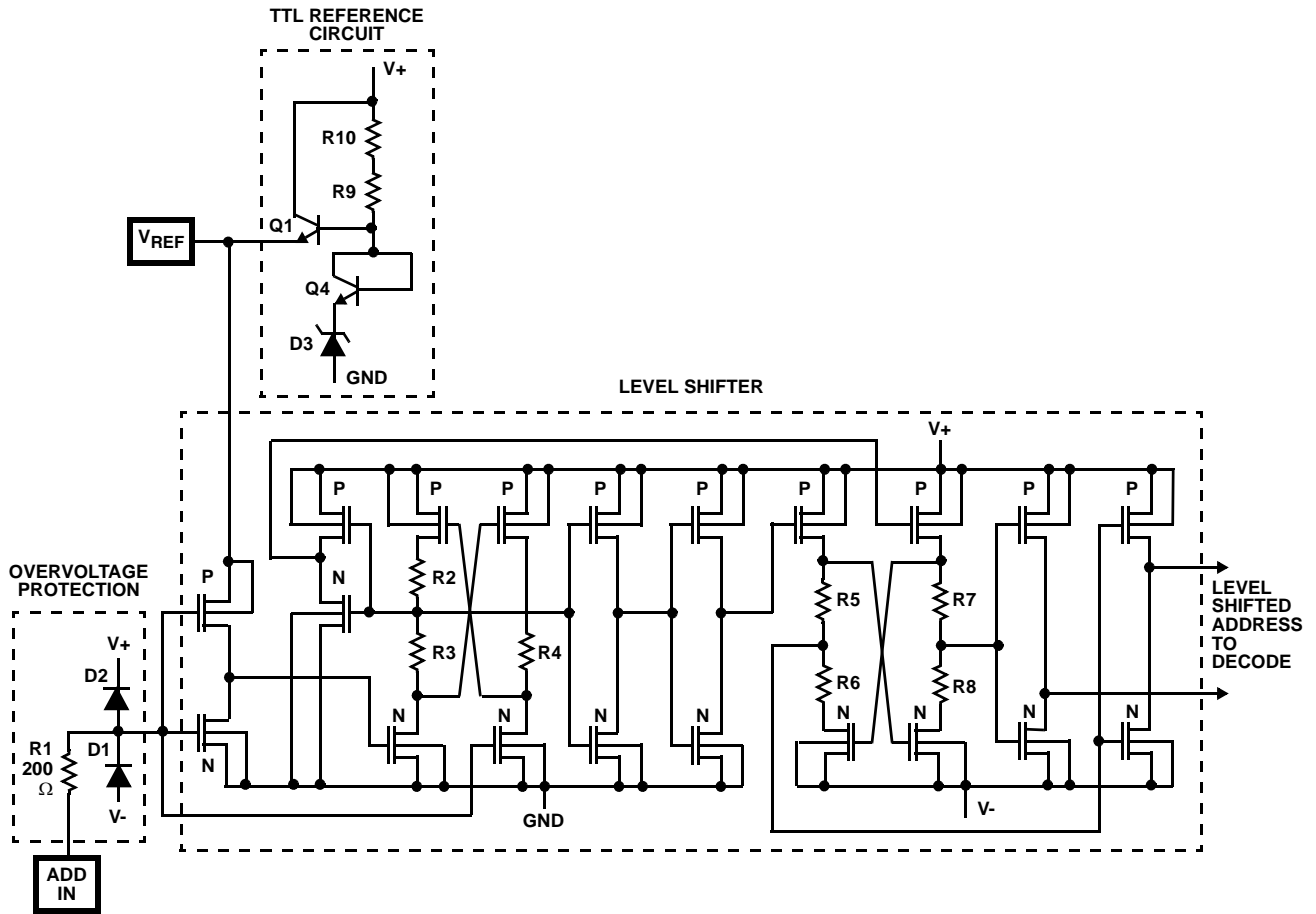

ADDRESS DECODER

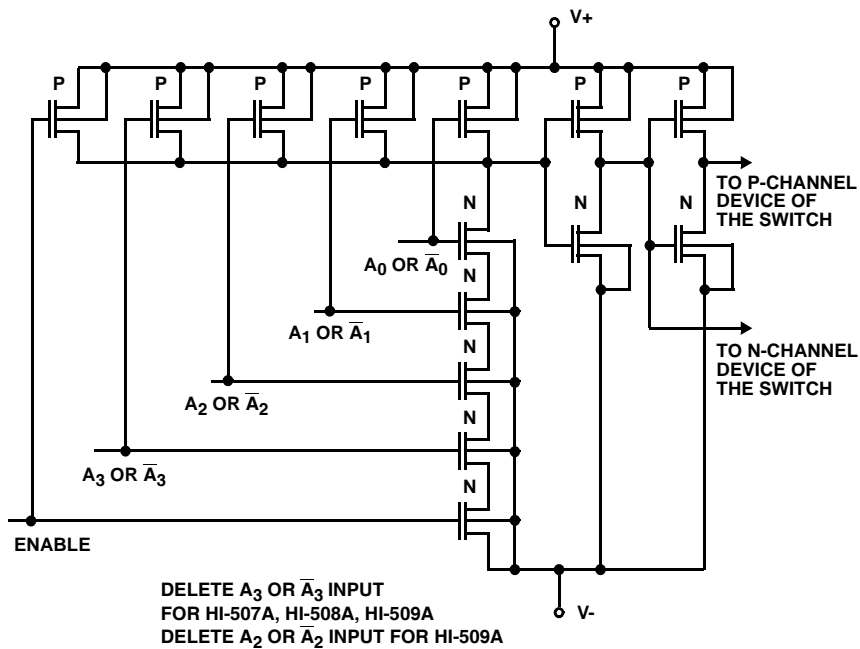

Schematic Diagrams (Continued)

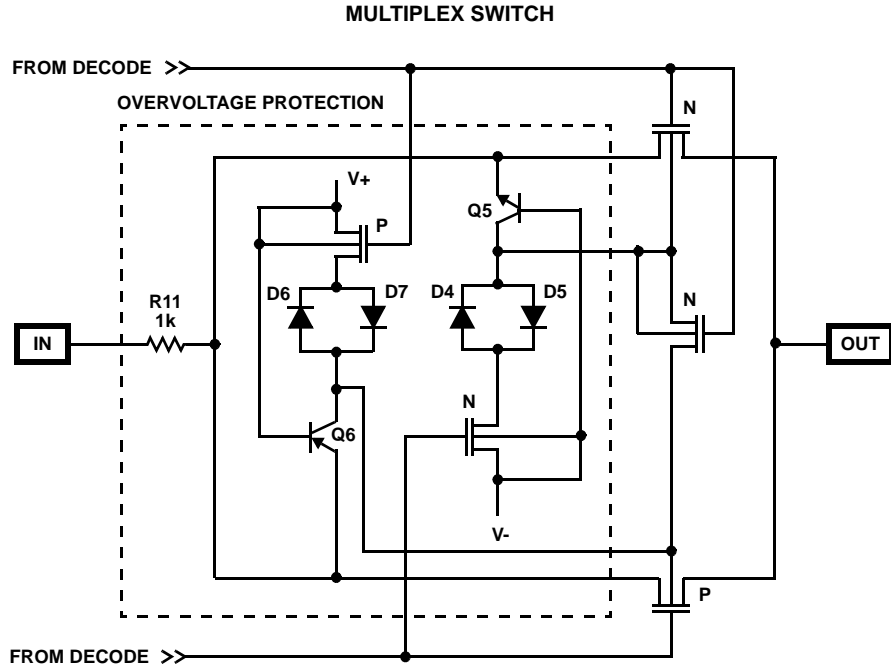

HI-506A, HI-507A, HI-508A, HI-509A

Absolute Maximum Ratings

V+ to V-+44V
V+ to GND+22V
V- to GND-25V
Digital Input Voltage (V _{EN} , V _A) (V-) -4V to (V+) +4V or 20mA, Whichever Occurs First
Analog Signal (V _{IN} , V _{OUT}) (V-) -20V to (V+) +20V
Continuous Current, IN or OUT 20mA
Peak Current, IN or OUT, Pulsed 1ms, 10% Duty Cycle (Max)	.. 40mA

Operating Conditions

Temperature Ranges	
HI-506A/507A/508A/509A-2, -8-55°C to +125°C
HI-506A/507A/508A/509A-5 0°C to +75°C

Thermal Information

Thermal Resistance (Typical, Note 3)	θ_{JA} (°C/W)	θ_{JC} (°C/W)
28 Ld CERDIP Package	55	18
16 Ld CERDIP Package	75	22
28 Ld PDIP Package	60	N/A
16 Ld PDIP Package	90	N/A
Maximum Junction Temperature		
CERDIP Packages +175°C	
PDIP Packages +150°C	
Maximum Storage Temperature Range-65°C to +150°C	
Pb-free reflow profilesee link below http://www.intersil.com/pbfree/Pb-FreeReflow.asp	

CAUTION: Do not operate at or near the maximum ratings listed for extended periods of time. Exposure to such conditions may adversely impact product reliability and result in failures not covered by warranty.

NOTE:

- θ_{JA} is measured with the component mounted on an evaluation PC board in free air.

Electrical Specifications Supplies = +15V, -15V; V_{REF} Pin = Open; V_{AH} (Logic Level High) = 4V; V_{AL} (Logic Level Low) = 0.8V, Unless Otherwise Specified. For Test Conditions, Consult Test Circuits Section.

PARAMETER	TEST CONDITIONS	TEMP (°C)	-2, -8			-5			UNITS
			MIN (Note 12)	TYP	MAX (Note 12)	MIN (Note 12)	TYP	MAX (Note 12)	
DYNAMIC CHARACTERISTICS									
Access Time, t _A	Note 4	25	-	0.5	-	-	0.5	-	μs
		Full	-	-	1.0	-	-	1.0	μs
Break-Before-Make Delay, t _{OPEN}	Note 4	25	25	80	-	25	80	-	ns
Enable Delay (ON), t _{ON(EN)}	Note 4	25	-	300	500	-	300	-	ns
		Full	-	-	1000	-	-	1000	ns
Enable Delay (OFF), t _{OFF(EN)}	Note 4	25	-	300	500	-	300	-	ns
		Full	-	-	1000	-	-	1000	ns
Settling Time, t _S HI-506A and HI-507A	To 0.1%	25	-	1.2	-	-	1.2	-	μs
	To 0.01%	25	-	3.5	-	-	3.5	-	μs
HI-508A and HI-509A	To 0.1%	25	-	1.2	-	-	1.2	-	μs
	To 0.01%	25	-	3.5	-	-	3.5	-	μs
Off Isolation	Note 9	25	-	68	-	-	68	-	dB
Channel Input Capacitance, C _{S(OFF)}		25	-	10	-	-	10	-	pF
Channel Output Capacitance, C _{D(OFF)}	HI-506A	25	-	52	-	-	52	-	pF
	HI-507A	25	-	30	-	-	30	-	pF
	HI-508A	25	-	25	-	-	25	-	pF
	HI-509A	25	-	12	-	-	12	-	pF
Digital Input Capacitance, C _A		25	-	10	-	-	10	-	pF
Input to Output Capacitance, C _{DS(OFF)}		25	-	0.1	-	-	0.1	-	pF
DIGITAL INPUT CHARACTERISTICS									
Input Low Threshold, TTL Drive, V _{AL}	Note 4	Full	-	-	0.8	-	-	0.8	V
Input High Threshold, V _{AH} (Note 11)	Note 4	Full	4.0	-	-	4.0	-	-	V

HI-506A, HI-507A, HI-508A, HI-509A

Electrical Specifications Supplies = +15V, -15V; V_{REF} Pin = Open; V_{AH} (Logic Level High) = 4V; V_{AL} (Logic Level Low) = 0.8V, Unless Otherwise Specified. For Test Conditions, Consult Test Circuits Section. **(Continued)**

PARAMETER	TEST CONDITIONS	TEMP (°C)	-2, -8			-5			UNITS	
			MIN (Note 12)	TYP	MAX (Note 12)	MIN (Note 12)	TYP	MAX (Note 12)		
Input Leakage Current (High or Low), I_A	Notes 4, 8	Full	-	-	1.0	-	-	1.0	μ A	
MOS Drive, V_{AL} , HI-506A/HI-507A	$V_{REF} = +10V$	25	-	-	0.8	-	-	0.8	V	
MOS Drive, V_{AH} , HI-506A/HI-507A	$V_{REF} = +10V$	25	6.0	-	-	6.0	-	-	V	
ANALOG CHANNEL CHARACTERISTICS										
Analog Signal Range, V_{IN}	Note 4	Full	-15	-	+15	-15	-	+15	V	
On Resistance, r_{ON}	Notes 4, 5	25	-	1.2	1.5	-	1.5	1.8	k Ω	
		Full	-	1.5	1.8	-	1.8	2.0	k Ω	
Off Input Leakage Current, $I_{S(OFF)}$	Notes 4, 6	25	-	0.03	-	-	0.03	-	nA	
		Full	-	-	50	-	-	50	nA	
Off Output Leakage Current, $I_{D(OFF)}$	Notes 4, 6	25	-	0.1	-	-	0.1	-	nA	
		Full	-	-	300	-	-	300	nA	
		HI-506A	Full	-	-	200	-	-	200	nA
		HI-507A	Full	-	-	200	-	-	200	nA
		HI-508A	Full	-	-	200	-	-	200	nA
$I_{D(OFF)}$ With Input Overvoltage Applied	Note 7	25	-	4.0	-	-	4.0	-	nA	
		Full	-	-	2.0	-	-	-	μ A	
On Channel Leakage Current, $I_{D(ON)}$	Notes 4, 6	25	-	0.1	-	-	0.1	-	nA	
		Full	-	-	300	-	-	300	nA	
		HI-506A	Full	-	-	200	-	-	200	nA
		HI-507A	Full	-	-	200	-	-	200	nA
		HI-508A	Full	-	-	200	-	-	200	nA
HI-509A	Full	-	-	100	-	-	100	nA		
Differential Off Output Leakage Current, I_{DIFF} , (HI-507A, HI-509A Only)		Full	-	-	50	-	-	50	nA	
POWER SUPPLY CHARACTERISTICS										
Current, I_+	Notes 4, 10	Full	-	0.5	2.0	-	0.5	2.0	mA	
Current, I_-	Notes 4, 10	Full	-	0.02	1.0	-	0.02	1.0	mA	
Power Dissipation, P_D		Full	-	7.5	-	-	7.5	-	mW	

NOTES:

4. 100% tested for Dash 8. Leakage currents not tested at -55°C.
5. $V_{OUT} = \pm 10V$, $I_{OUT} = \bar{\pm} 100\mu A$.
6. 10nA is the practical lower limit for high speed measurement in the production test environment.
7. Analog Overvoltage = $\pm 33V$.
8. Digital input leakage is primarily due to the clamp diodes (see Schematic). Typical leakage is less than 1nA at +25°C.
9. $V_{EN} = 0.8V$, $R_L = 1k$, $C_L = 15pF$, $V_S = 7V_{RMS}$, $f = 100kHz$.
10. V_{EN} , $V_A = 0V$ or 4V.
11. To drive from DTL/TTL Circuits, 1k Ω pull-up resistors to +5V supply are recommended.
12. Parts are 100% tested at +25°C. Over-temperature limits established by characterization and are not production tested.

Test Circuits and Waveforms

$T_A = +25^\circ\text{C}$, $V_{\text{SUPPLY}} = \pm 15\text{V}$, $V_{\text{AH}} = 4\text{V}$, $V_{\text{AL}} = 0.8\text{V}$, $V_{\text{REF}} = \text{Open}$,
Unless Otherwise Specified

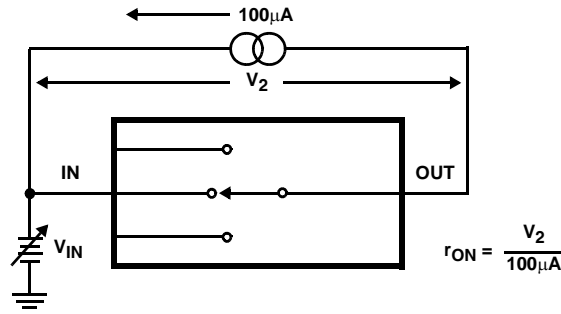

FIGURE 1A. TEST CIRCUIT

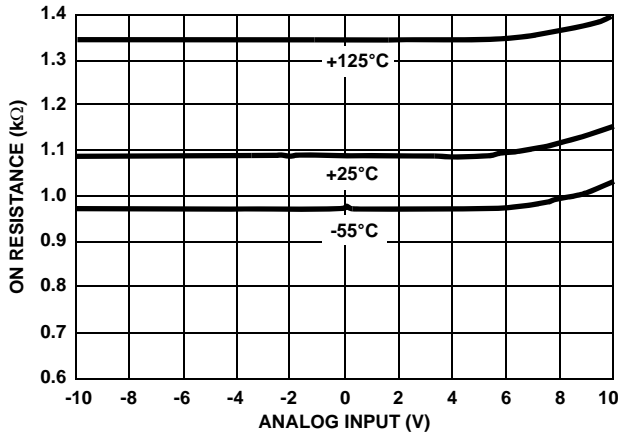

FIGURE 1B. ON RESISTANCE vs ANALOG INPUT VOLTAGE

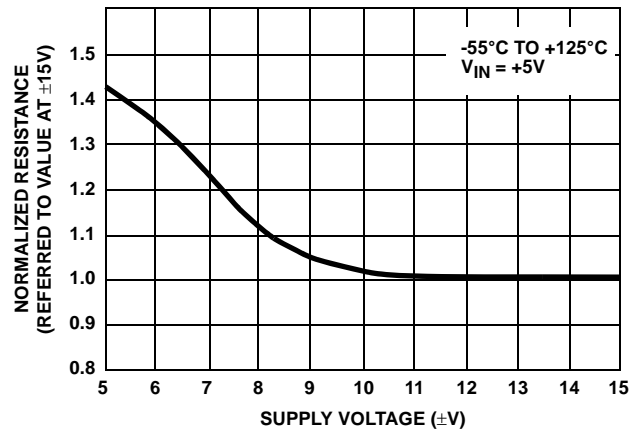

FIGURE 1C. NORMALIZED ON RESISTANCE vs SUPPLY VOLTAGE

FIGURE 1. ON RESISTANCE

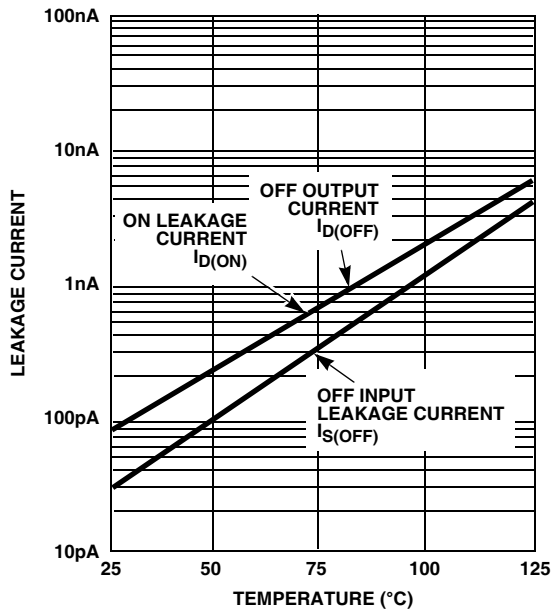

FIGURE 2A. LEAKAGE CURRENT vs TEMPERATURE

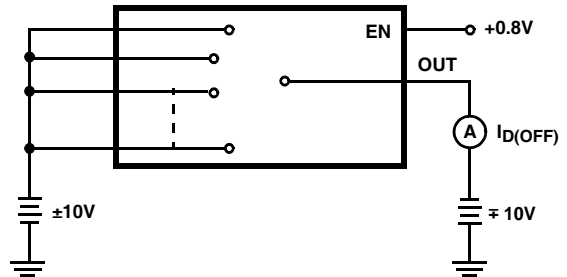

FIGURE 2B. $I_{D(OFF)}$ TEST CIRCUIT (NOTE 13)

Test Circuits and Waveforms

$T_A = +25^\circ\text{C}$, $V_{\text{SUPPLY}} = \pm 15\text{V}$, $V_{\text{AH}} = 4\text{V}$, $V_{\text{AL}} = 0.8\text{V}$, $V_{\text{REF}} = \text{Open}$,
Unless Otherwise Specified (Continued)

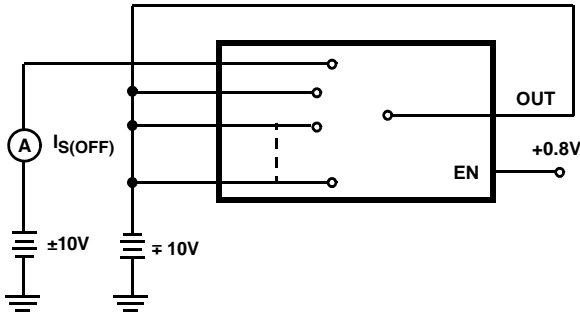

FIGURE 2C. $I_{\text{S(OFF)}}$ TEST CIRCUIT (NOTE 13)

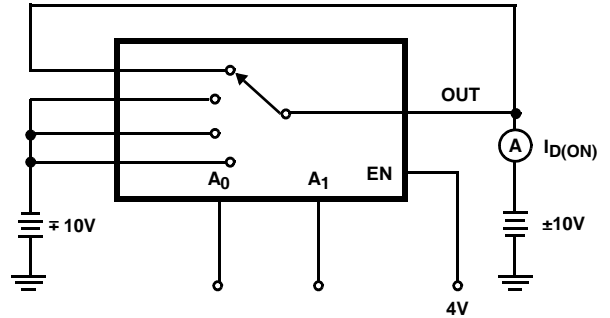

FIGURE 2D. $I_{\text{D(ON)}}$ TEST CIRCUIT (NOTE 13)

NOTE:

13. Two measurements per channel: $\pm 10\text{V}$ and $\mp 10\text{V}$. (Two measurements per device for $I_{\text{D(OFF)}}$ $\pm 10\text{V}$ and $\mp 10\text{V}$.)

FIGURE 2. LEAKAGE CURRENTS

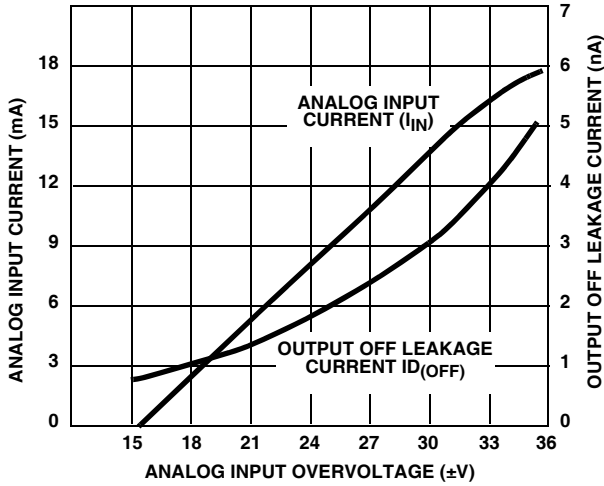

FIGURE 3A. ANALOG INPUT OVERVOLTAGE CHARACTERISTICS

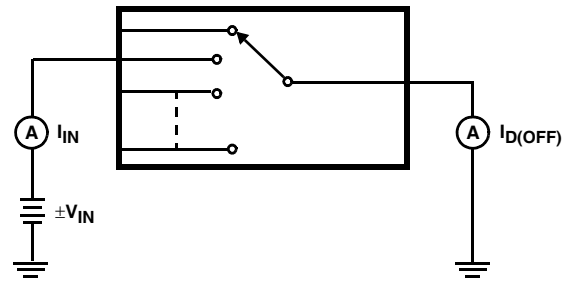

FIGURE 3B. TEST CIRCUIT

FIGURE 3. ANALOG INPUT OVERVOLTAGE CHARACTERISTICS

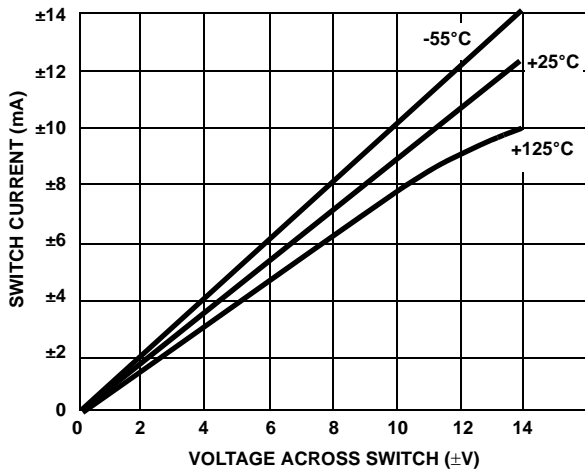

FIGURE 4A. ON CHANNEL CURRENT vs VOLTAGE

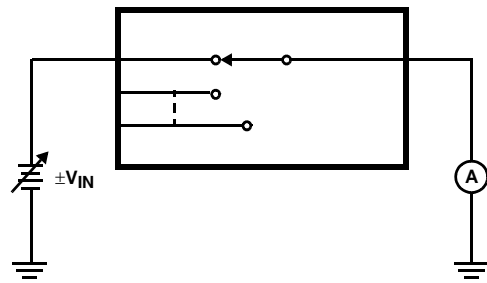

FIGURE 4B. TEST CIRCUIT

FIGURE 4. ON CHANNEL CURRENT

Test Circuits and Waveforms

$T_A = +25^\circ\text{C}$, $V_{\text{SUPPLY}} = \pm 15\text{V}$, $V_{\text{AH}} = 4\text{V}$, $V_{\text{AL}} = 0.8\text{V}$, $V_{\text{REF}} = \text{Open}$,
Unless Otherwise Specified (Continued)

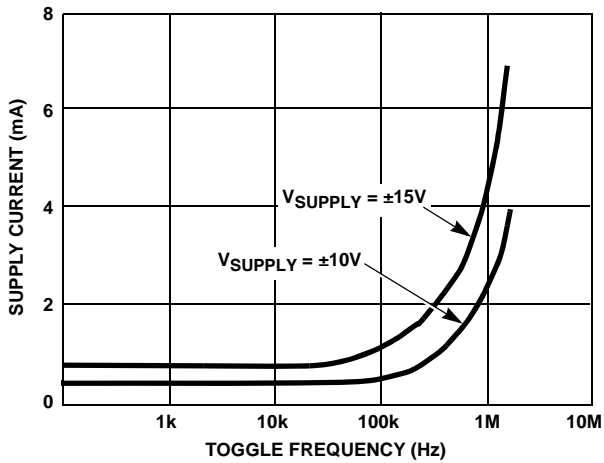
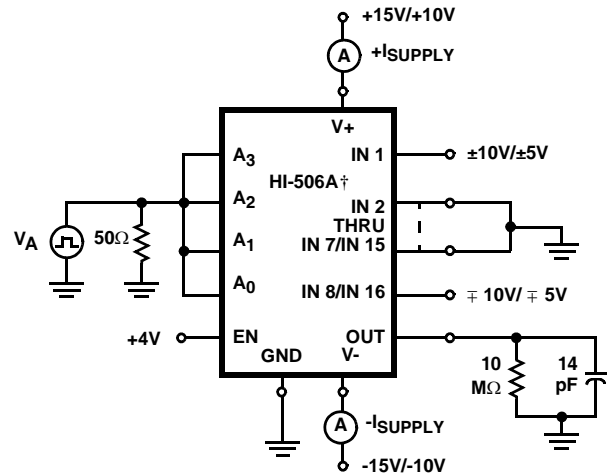

FIGURE 5A. SUPPLY CURRENT vs TOGGLE FREQUENCY



† Similar connection for HI-507A/HI-508A/HI-509A

FIGURE 5B. TEST CIRCUIT

FIGURE 5. DYNAMIC SUPPLY CURRENT

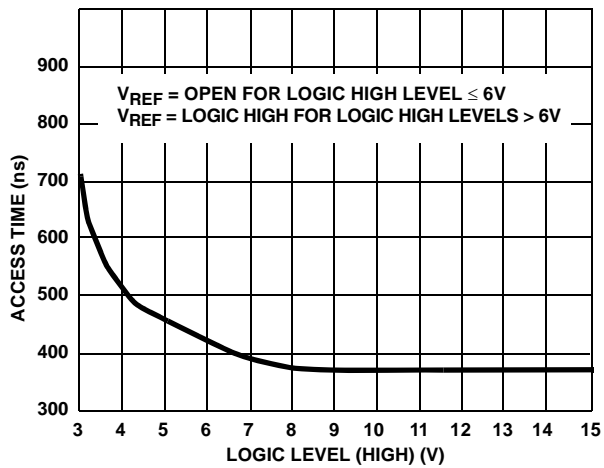
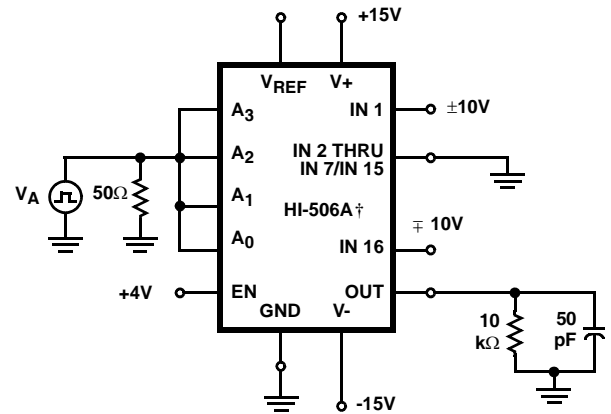

FIGURE 6A. ACCESS TIME vs LOGIC LEVEL (HIGH)



† Similar connection for HI-507A/HI-508A/HI-509A

FIGURE 6B. TEST CIRCUIT

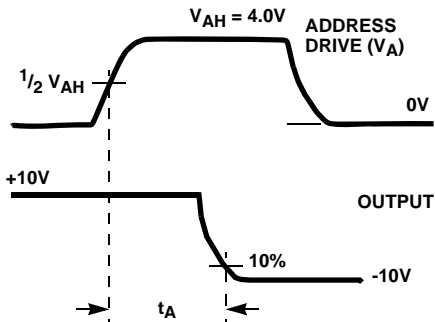

FIGURE 6C. MEASUREMENT POINTS

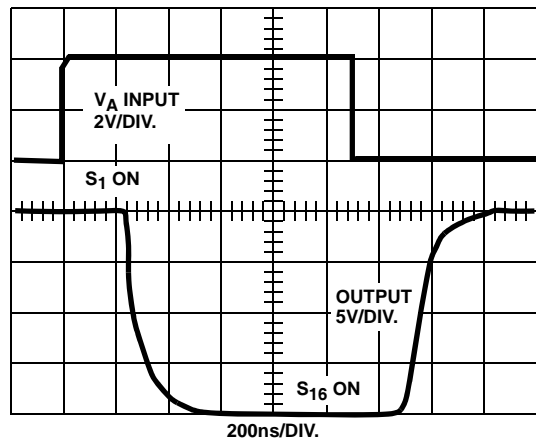
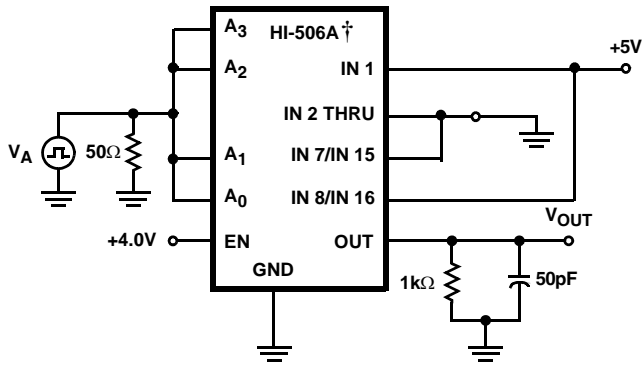

FIGURE 6D. WAVEFORMS

FIGURE 6. ACCESS TIME

Test Circuits and Waveforms

$T_A = +25^\circ\text{C}$, $V_{\text{SUPPLY}} = \pm 15\text{V}$, $V_{\text{AH}} = 4\text{V}$, $V_{\text{AL}} = 0.8\text{V}$, $V_{\text{REF}} = \text{Open}$,
Unless Otherwise Specified (Continued)



† Similar connection for HI-507A/HI-508A/HI-509A

FIGURE 7A. TEST CIRCUIT

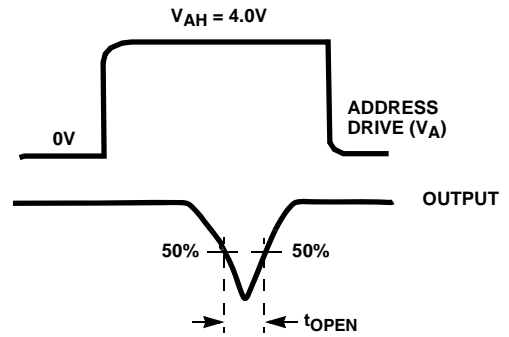

FIGURE 7B. MEASUREMENT POINTS

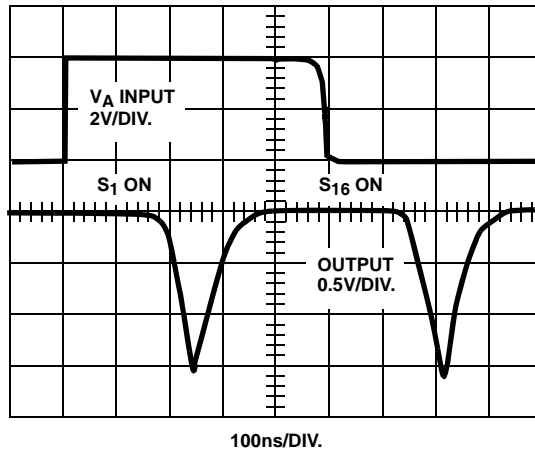
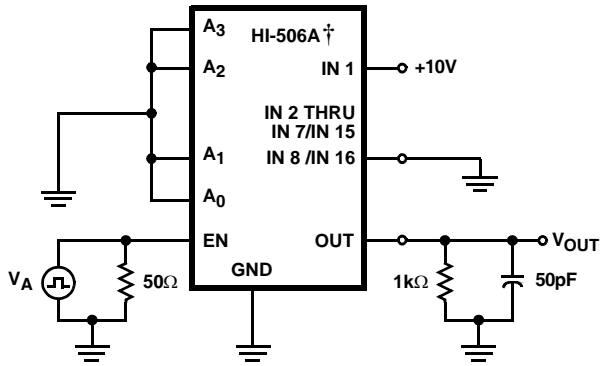

FIGURE 7C. WAVEFORMS

FIGURE 7. BREAK-BEFORE-MAKE DELAY

Test Circuits and Waveforms

$T_A = +25^\circ\text{C}$, $V_{\text{SUPPLY}} = \pm 15\text{V}$, $V_{\text{AH}} = 4\text{V}$, $V_{\text{AL}} = 0.8\text{V}$, $V_{\text{REF}} = \text{Open}$,
Unless Otherwise Specified (Continued)



† Similar connection for HI-507A/HI-508A/HI-509A

FIGURE 8A. TEST CIRCUIT

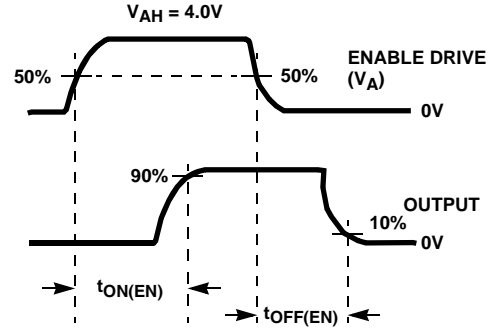

FIGURE 8B. MEASUREMENT POINTS

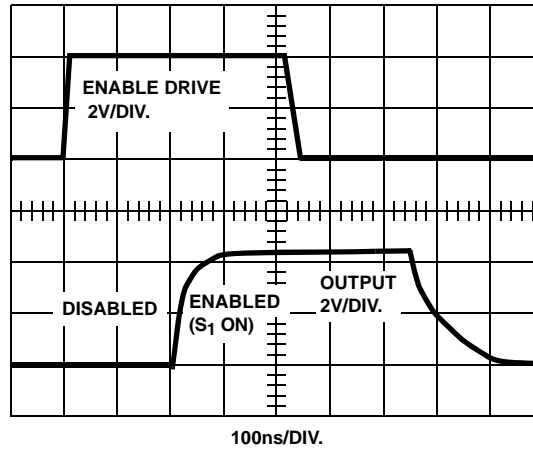

FIGURE 8C. WAVEFORMS

FIGURE 8. ENABLE DELAYS

Die Characteristics

DIE DIMENSIONS:

159 mils x 83.9 mils

METALLIZATION:

Type: CuAl

Thickness: 16kÅ ±2kÅ

SUBSTRATE POTENTIAL (NOTE):

-V_{SUPPLY}

PASSIVATION:

Silox: 12kÅ ±2kÅ

Nitride: 3.5kÅ ±1kÅ

WORST CASE CURRENT DENSITY:

1.4 x 10⁵ A/cm²

TRANSISTOR COUNT:

485

PROCESS:

CMOS-DI

NOTE: The substrate appears resistive to the -V_{SUPPLY} terminal, therefore it may be left floating (Insulating Die Mount) or it may be mounted on a conductor at -V_{SUPPLY} potential.

Metallization Mask Layouts

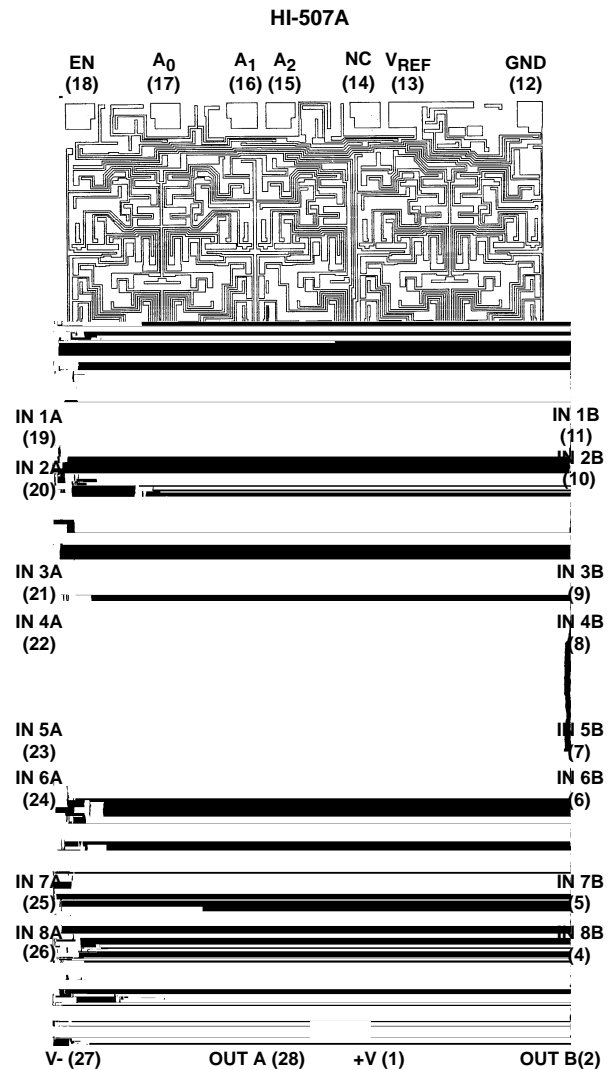
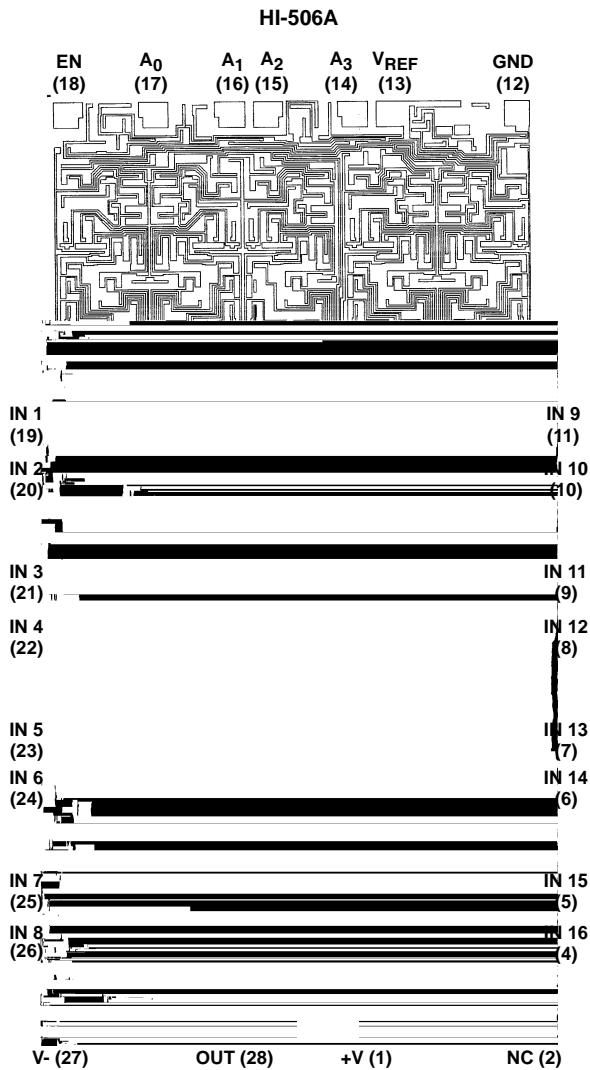

Die Characteristics

DIE DIMENSIONS:

108 mils x 83 mils

METALL9[3IZ9[3A)76.5(T)-1.5(IO)5.5(N:)T/T4 1 Tf1.3333 -1.6667 TD-0.0575 Tc0.0597 T(W)-57.5(p)-54.7(e)-61.3(:)-53(C)-55.3(u)-54.7(A)

Lead Frit Seal Packages (CERDIP)

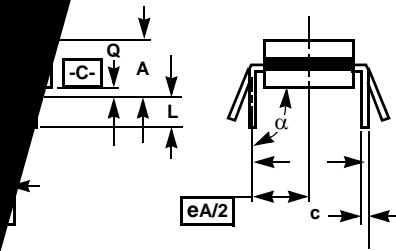
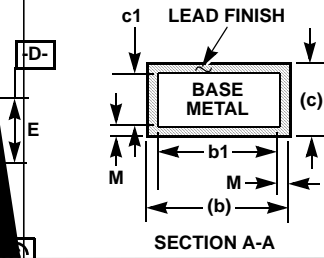

For a pin one identification mark shall be located on the lead surface and shall be located within the shaded area. The manufacturer's identification shall not be used for the identification mark.

Dimensions of lead dimensions b and c or M shall be measured to the centroid of the finished lead surfaces, when a plate lead finish is applied.

Dimensions c1 and c apply to lead base metal only. Dimension c1 includes lead plating and finish thickness.

Dimensions (1, N, N/2, and N/2+1) may be configured with a paddle. For this configuration dimension b3 replaces b2.

Dimension allows for off-center lid, meniscus, and glass

Dimension Q shall be measured from the seating plane to the lead surface.

Measure dimension S1 at all four corners.

Dimension S1 shall be the maximum number of terminal positions.

Dimensioning and tolerancing per ANSI Y14.5M - 1982.

Controlling dimension: INCH.

Dual-In-Line Plastic Packages (PDIP)

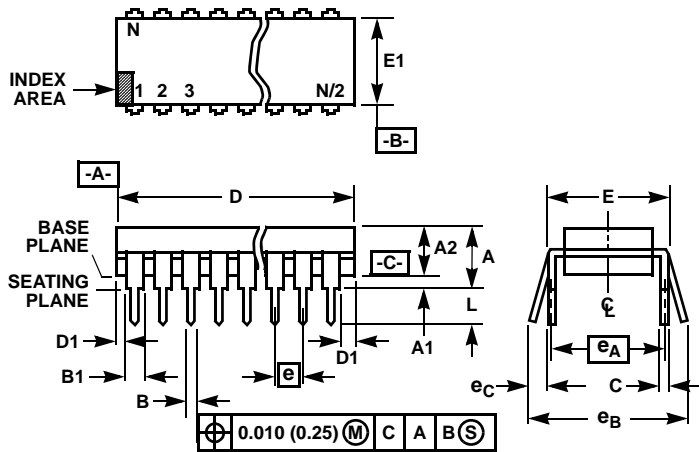

NOTES:

- Controlling Dimensions: INCH. In case of conflict between English and Metric dimensions, the inch dimensions control.
- Dimensioning and tolerancing per ANSI Y14.5M-1982.
- Symbols are defined in the "MO Series Symbol List" in Section 2.2 of Publication No. 95.
- Dimensions A, A1 and L are measured with the package seated in JEDEC seating plane gauge GS-3.
- D, D1, and E1 dimensions do not include mold flash or protrusions. Mold flash or protrusions shall not exceed 0.010 inch (0.25mm).
- E and e_A are measured with the leads constrained to be perpendicular to datum $-C-$.
- e_B and e_C are measured at the lead tips with the leads unconstrained. e_C must be zero or greater.
- B1 maximum dimensions do not include dambar protrusions. Dambar protrusions shall not exceed 0.010 inch (0.25mm).
- N is the maximum number of terminal positions.
- Corner leads (1, N, N/2 and N/2 + 1) for E8.3, E16.3, E18.3, E28.3, E42.6 will have a B1 dimension of 0.030 - 0.045 inch (0.76 - 1.14mm).

E28.6 (JEDEC MS-011-AB ISSUE B)
28 LEAD DUAL-IN-LINE PLASTIC PACKAGE

SYMBOL	INCHES		MILLIMETERS		NOTES
	MIN	MAX	MIN	MAX	
A	-	0.250	-	6.35	4
A1	0.015	-	0.39	-	4
A2	0.125	0.195	3.18	4.95	-
B	0.014	0.022	0.356	0.558	-
B1	0.030	0.070	0.77	1.77	8
C	0.008	0.015	0.204	0.381	-
D	1.380	1.565	35.1	39.7	5
D1	0.005	-	0.13	-	5
E	0.600	0.625	15.24	15.87	6
E1	0.485	0.580	12.32	14.73	5
e	0.100 BSC		2.54 BSC		-
e_A	0.600 BSC		15.24 BSC		6
e_B	-	0.700	-	17.78	7
L	0.115	0.200	2.93	5.08	4
N	28		28		9

Rev. 1 12/00

Ceramic Dual-In-Line

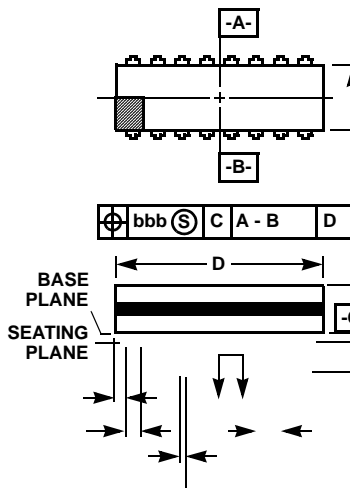

NOTES:

1. Index area: A notch or a pin one lead adjacent to pin one and shall be as shown. The manufacturer shall use this area as a pin one identification mark.
2. The maximum limits of lead dimensions shall be measured at the centroid of the solder dip or tin plate lead finish.
3. Dimensions b1 and c1 apply to the lead body. Dimension M applies to lead plating and finish.
4. Corner leads (1, N, N/2, and N/4) shall be measured to the lead tip. For this condition, dimension b2 applies.
5. This dimension allows for off-centering of the lead tip.
6. Dimension Q shall be measured to the base plane.
7. Measure dimension S1 at all four leads.
8. N is the maximum number of terminals.
9. Dimensioning and tolerancing shall be in accordance with ASME Y14.5M.
10. Controlling dimension: INCH.

Dual-In-Line Plastic Packages (PDIP)

NOTES:

1. Controlling Dimensions: INCH. In case of conflict between English and Metric dimensions, the inch dimensions control.
2. Dimensioning and tolerancing per ANSI Y14.5M-1982.
3. Symbols are defined in the "MO Series Symbol List" in Section 2.2 of Publication No. 95.
4. Dimensions A, A1 and L are measured with the package seated in JEDEC seating plane gauge GS-3.
5. D, D1, and E1 dimensions do not include mold flash or protrusions. Mold flash or protrusions shall not exceed 0.010 inch (0.25m8556H7and

All Intersil U.S. products are manufactured, assembled and tested utilizing ISO9000 quality systems. Intersil Corporation's quality certifications can be viewed at www.intersil.com/design/quality

Intersil products are sold by description only. Intersil Corporation reserves the right to make changes in circuit design, software and/or specifications at any time without notice. Accordingly, the reader is cautioned to verify that data sheets are current before placing orders. Information furnished by Intersil is believed to be accurate and reliable. However, no responsibility is assumed by Intersil or its subsidiaries for its use; nor for any infringements of patents or other rights of third parties which may result from its use. No license is granted by implication or otherwise under any patent or patent rights of Intersil or its subsidiaries.

For information regarding Intersil Corporation and its products, see www.intersil.com