



P11 PA11

modular potentiometers with cermet (P11) or conductive plastic elements (PA11)

1 W at 70°C
CECC 41 301-004
NF C 83-253
MIL-R-94
GAM-T-1
LNZ

- P11 version for industrial and military applications
- PA11 version for professional audio applications
- T11/TA11 trimmer version

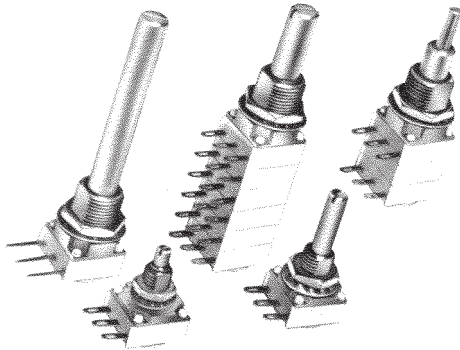

- MINIATURE MODULE SIZE : 12,5 mm SQUARE
- FIVE SHAFT DIAMETERS
- TEN TERMINAL STYLES
- MULTIPLE ASSEMBLIES - UP TO SEVEN MODULES
- SHAFT AND PANEL SEALED VERSION
- UP TO TWENTY-ONE INDENT POSITIONS
- SWITCH MODULES
- CONCENTRIC SHAFTS
- TRIMMER VERSION T11/TA11 (see data sheet 2.413 E)
- MOTORIZED VERSION (see data sheet 2.458 E)
- LONG LIFE APPLICATIONS (1 Million cycles)
- CUSTOM DESIGNS

VERSATILE

MODULAR

COMPACT

ROBUST

SPECIFICATIONS

ELECTRTICAL

	PA11	P11
RESISTIVE ELEMENT	Conductive plastic	Cermet
ELECTRICAL TRAVEL	270° ±10°	270° ±10°
RESISTANCE RANGE	1 kΩ to 500 kΩ 470 Ω to 220 kΩ	22 Ω to 4,7 MΩ 470 Ω to 1 MΩ
TOLERANCE	± 20 % ± 10 % (470 Ω to 100 kΩ)	± 20 % or ± 10 % ± 5 %
POWER RATING	0,5 W at + 70°C 0,5 W at + 70°C 0,5 W at + 70°C per module ± 500 ppm/°C typical	1 W at + 70°C 0,5 W at + 70°C 0,5 W at + 70°C per module ± 100 ppm/°C (R≥100Ω)
TEMPERATURE COEFFICIENT		
LIMITING ELEMENT VOLTAGE	350 V	350 V
CONTACT RESISTANCE VARIATION	1 %	2 % or 3 %
END RESISTANCE (typical)	2 Ω	2 Ω
INDEPENDENT LINEARITY (typical)	± 3 %	± 3 %
INSULATION RESISTANCE	10 ⁶ MΩ min.	10 ⁶ MΩ min.
DIELECTRIC STRENGTH	1500 V RMS min.	1500 V RMS min.
ATTENUATION	90 dB max. and 0,05 dB min.	
MECHANICAL ROTATIONAL LIFE	50 000 cycles	50.000 cycles
ENVIRONMENTAL		
TEMPERATURE RANGE	-55°C +125°C	-55°C +125°C
CLIMATIC CATEGORY	55 / 125 / 21	55 / 125 / 56
SEALING	IP64	IP64

MECHANICAL PA11 and P11

MECHANICAL TRAVEL	300° ±5°
OPERATING TORQUE	
Single and dual assemblies :	
3 mm, 4 mm (1/8") dia. shafts	0,5 to 1,3 Ncm max. (0,7 to 1,4 oz-inch max.)
6 mm (1/4") dia. shafts	0,7 to 1,5 Ncm max. (1 to 1,9 oz-inch max.)
Three to seven modules (per module)	0,2 to 0,3 Ncm max. (0,3 to 0,45 oz-inch max.)
END STOP TORQUE	
3 mm, 4 mm (1/8") dia. shafts	35 Ncm max. (3 lb-inch max.)
6 mm (1/4") dia. shafts	80 Ncm max. (6,8 lb-inch max.)
TIGHTENING TORQUE	
6 mm, 7 mm (1/4") dia. bushings	150 Ncm max. (13 lb-inch max.)
10 mm (3/8") dia. bushings	250 Ncm max. (21 lb-inch max.)
WEIGHT	7 g to 9 g per module (0,25 to 0,32 oz)

VARIATIONS LAWS

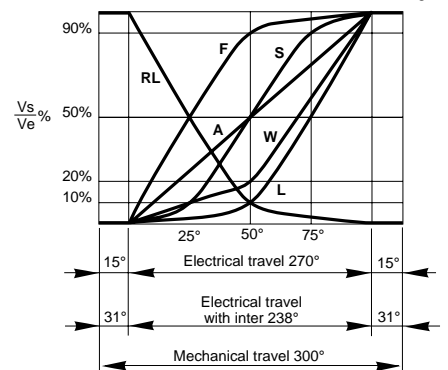

PLASTIC MATERIALS USED ARE UL 94 class VO

DIMENSIONAL CONFIGURATIONS in mm (inches)

PCB pin out A - A₁ - A₂ / X - X₁ - X₂ / Z - Z₁ - Z₂ / W - W₁ - W₂

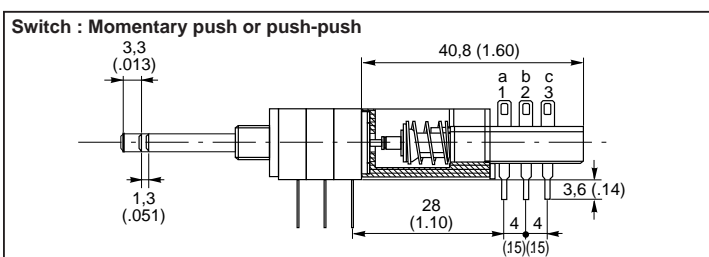
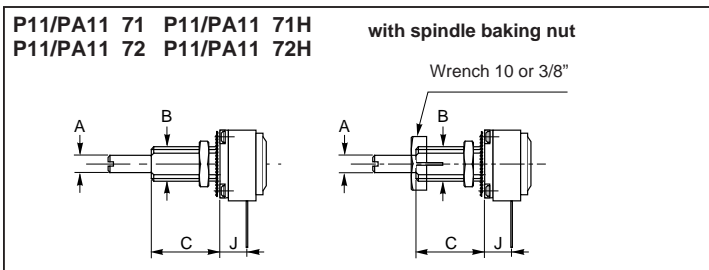
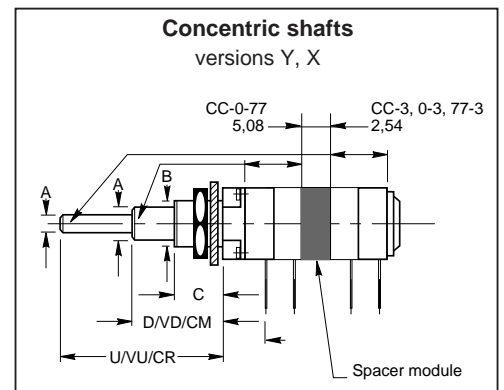
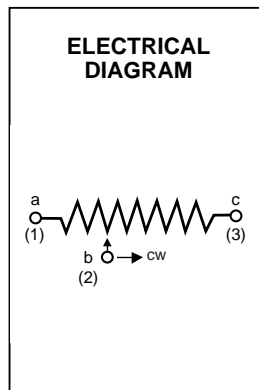
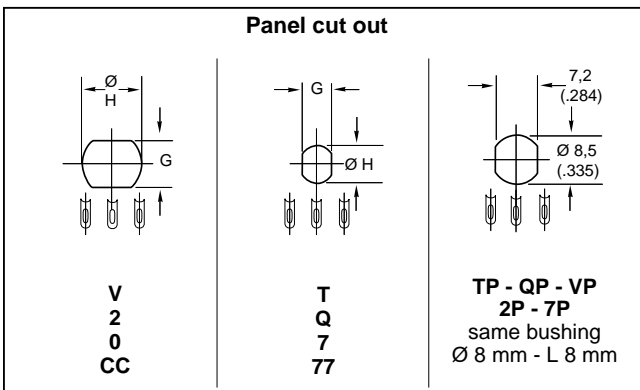
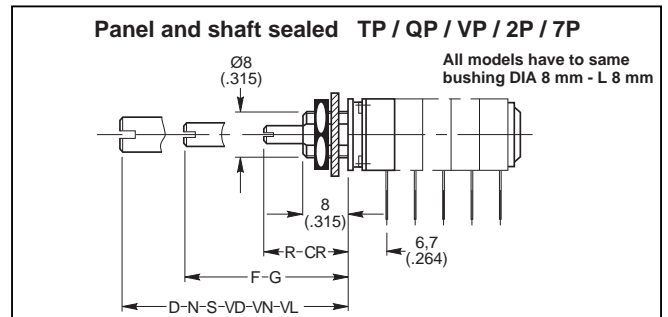
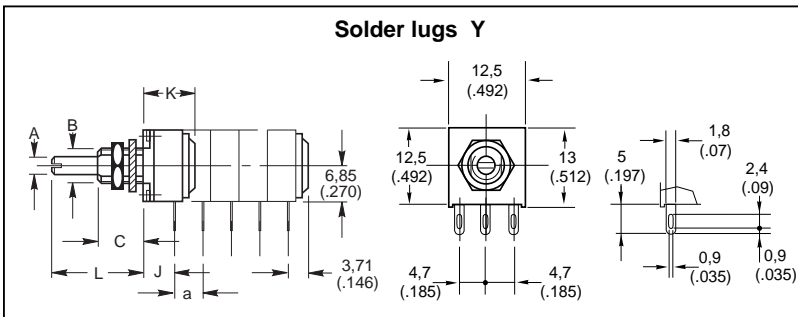
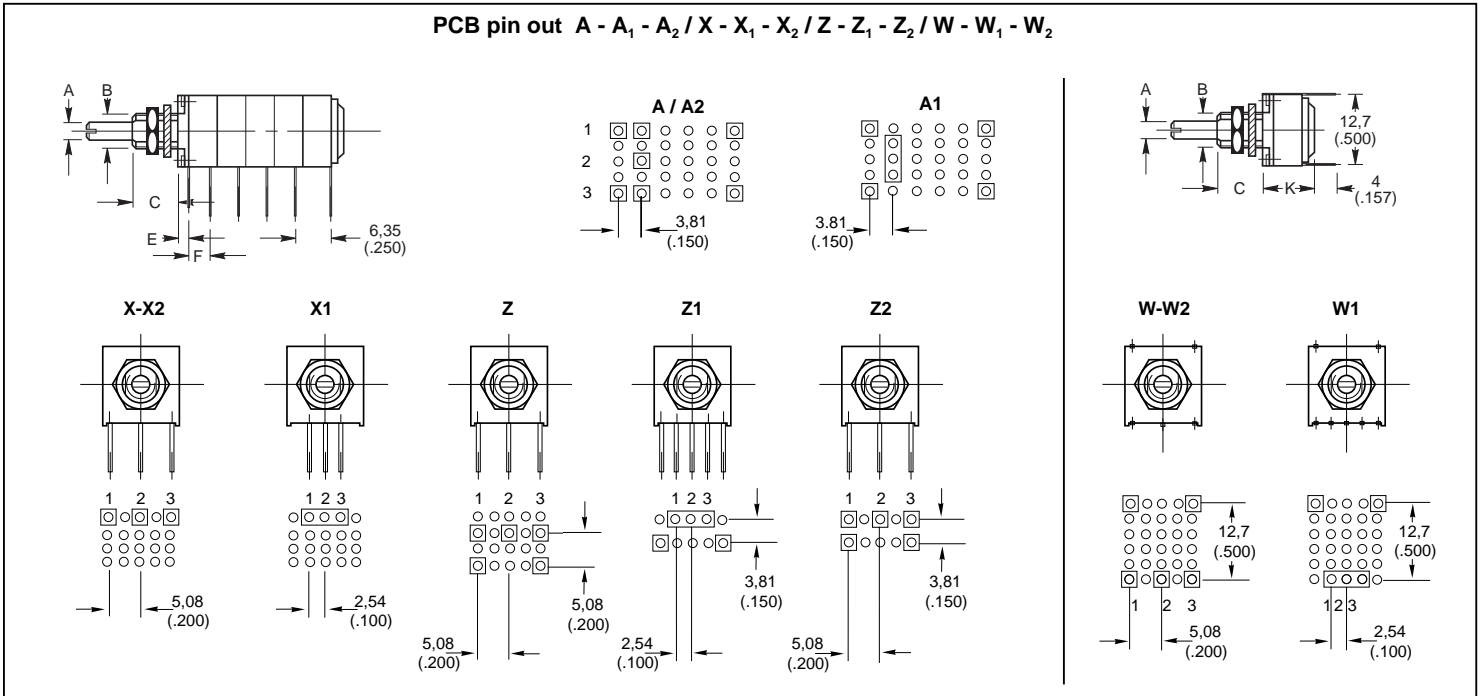

The position of each module is free

Shafts	T	Q	V	CC	7	71	72	2	0	77	
	dimensions mm ± 0,5				dimensions inches ± (.01)						
A Shafts Ø	3	4	6	3/3	1/8"	1/8"	1/8"	1/4"	1/8" 1/4"	.07 1/8"	
B Bushing Ø	6	7	10	10	1/4"	1/4"	1/4"	3/8"	3/8"	1/4"	
C L	8	8	9,5	9,5	1/4"	3/8"	1/2"	3/8"	3/8"	1/4"	
J versions Y, X, X ₁ , X ₂	5	5	7	7	.200	.200	.200	.278	.278	.200	
K	9,1	9,1	11,1	-	.357	.357	.357	.436	-	-	
E version Z	1,8	1,8	3,8	3,8	.071	.071	.071	.150	.150	.071	
E ₁ versions Z ₁ , Z ₂ , A, A ₁ , A ₂	1,6	1,6	3,6	3,6	.063	.063	.063	.14	.14	.063	
F*	version Z : 5,08 (.200)				versions A- A ₁ -A ₂ -Z ₁ -Z ₂ : 3,81 (.150)						
G Panel	5,2	6,2	8,2	8,2	.197	.197	.197	.323	.323	.197	
H Cutout Ø	6,5	7,5	10,5	10,5	.268	.268	.268	.394	.394	.268	
a	variable 5,08 (.200)			7,62 (.300)	10,16 (.400)						
Thread	M 0,75				32 threads/inch						
Nut	8	10	12	12	.313	.313	.313	.500	.500	.313	
Shaft lengths L	Measurement from the mounting face, see ordering procedure										

* When switch in first position F = 3,5 (.138)



VISHAY S.A.
International Department
199, Boulevard de la Madeleine
B.P. 1159
F 06003 NICE CEDEX 1
Tel. : (33) 04 93 37 27 27
Fax. : (33) 04 93 37 27 26

ENVIRONMENTAL PERFORMANCES

Table 1

TESTS	CONDITIONS	VTYPICAL VALUES AND DRIFTS		
		P11 Cermet	PA11 plastique conducteur	
LOAD LIFE	1000 h at +70°C (90/30')	total resistance shift	2%	5%
		contact resistance variation	4%	5%
TEMPERATURE CYCLE	5 cycles -55°C to 125°C	total resistance shift	0,2%	0,5% typiqcal
MOISTURE	+40°C 98% relative humidity	total resistance shift insulation resistance	56 days 2% >1000 MΩ	21 days 5% >10 MΩ
ROTATIONAL LIFE	P11 / PA 11 : 50 000 cycles	total resistance shift contact resistance variation	5% 5%	6% 2%
CLIMATIC SEQUENCE	Dry heat +125°C / Damp heat Cold -55°C / Damp heat 5 cycles	total resistance shift	1%	-
SHOCKS	50 G 11 ms 3 shocks - 3 directions	total resistance shift resistance setting charge	0,2% 0,5%	0,2% 0,5% typical
VIBRATIONS	10 - 55 Hz 0,75 mm or 10 G 6 hours	total resistance shift voltage setting charge	0,2 % 0,5% typical	0,2 % 0,5% typical

STANDARD RESISTANCE ELEMENT DATA

Table 2

Standard resistance values	P11 Cermet						PA11 Conductive plastic			CT -55°C +125°C	
	LINEAR LAW			NON LINEAR LAWS			Max. power at 70°C	Max. working voltage	Max. cur. through wiper	P11	PA11
	Max. power at 70°C	Max. working voltage	Max. cur. through wiper	Max. power at 70°C	Max. working voltage	Max. cur. through wiper					
Ω	W	V	mA	W	V	mA	W	V	mA	ppm/°C	
22 47	1	4,69 6,85	213,2 145,8							± 200	
100 200 470		10 14,8 21,6	100 67,4 46,1								
1 k 2,2 k 4,7 k		31,6 46,9 63,5	31,6 21,3 14,5	0,5	15,3 22,4 33,2	32,7 22,4 15,1			0,5	22,4 33,2 48,5	22,4 15,1 10,3
10 k 22 k 47 k		100 148,3 216,7	10 6,7 4,6		105 153 224	7,07 4,77 3,26				79,7 105 153	7,07 4,77 3,26
100 k 220 k 470 k	1	316,2 350 350	3,16 1,59 0,75	0,5	332 350	2,24 0,74	0,5	0,5	0,5	224 332 350	2,24 1,51 0,74
1 M 2,2 M 4,7 M	0,12 0,05 0,02	350 350 350	0,35 0,16 0,07	0,26 0,12	350	0,35	0,26	0,26	0,26	350	0,74

POWER RATING CHART

Fig. 2

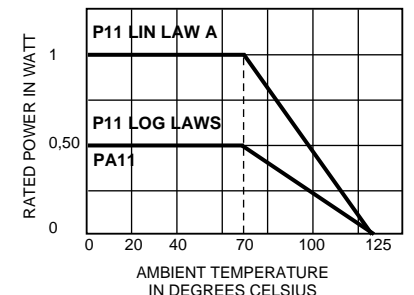

MULTIPLE ASSEMBLIES

Standard assemblies can comprise up to 7 modules in addition to the shaft and bushing module.
 Detents module (CV)
 Switch modules (RS or RSI)
 Potentiometer modules
 Spacer module to increase the distance between rows of pins from 5,06 mm (.200) to 10,16 mm (.400).
 Screening module, with ground terminal.

The position of each module is free except the push/push, momentary push and motor which has to be the last module.

LINEARITY - CONFORMITY

Fig. 3

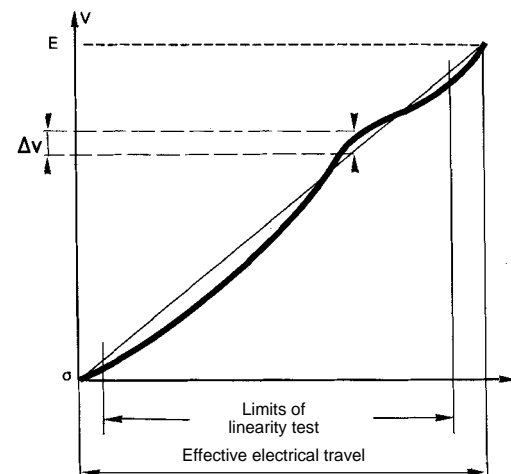

The independent linearity (conformity for the non linear laws) is the maximum gap Δv between the actual variation curve and the theoretical variation curve the nearest to it. The linearity and the conformity are expressed in percentage of the total applied voltage E

$$\text{linearity / conformity} = \pm \frac{\Delta v \text{ max.}}{E} \%$$

They are measured over 90% of actual electrical travel (centered).

On request linearity can be guaranteed in linear law. For example: linearity $\pm 2\% + J 145$ option (see ordering procedure).

INTERLINEARITY - INTERCONFORMITY

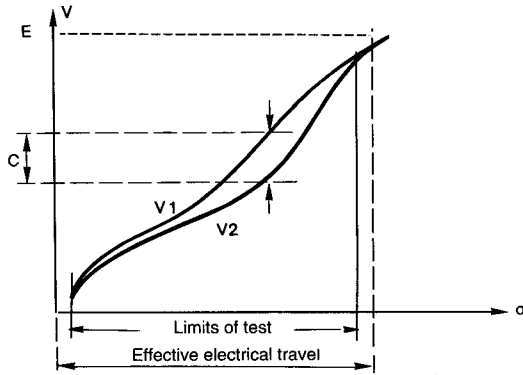

Fig. 4

It is the maximum deviation between the actual voltage outputs of 2 or more pot modules in the same assembly. It is expressed as a percentage of the total applied voltage, or preferably in dB attenuation.

Interlinearity is measured between 2 pot modules, over 10 to 90 % of the total electrical travel.

The interlinearity or interconformity is expressed as a percentage of the total applied voltage :

$$I\% = \frac{IC1}{E}$$

Or in decibels by comparison between outputs V_1 and V_2

$$I \text{ dB} = 20 \log \frac{V_1}{V_2}$$

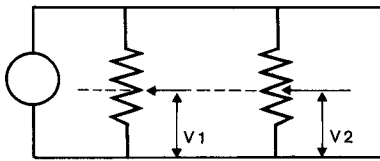

Fig. 5

Here under (table 3) are the best interlinearities between modules. The first one is the reference. Empty modules CV, screen modules are understood as modules.

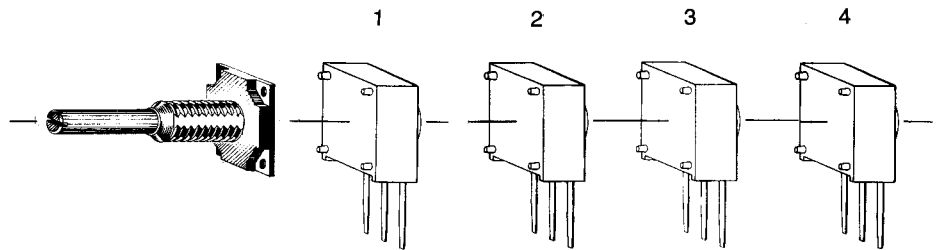

Fig. 6

Table 3

OPTIONAL EXTRAS	Variation Laws (tapers)	% effective electrical travel	Attenuation	Level in dB		
				2nd module	3rd module	4th module
J 116	A law	2,5 % ... 5 %	32 dB ... 26 dB	1,6	2	2,4
	A law + switch	5 % ... 10 %	26 dB ... 20 dB	0,8	1,2	1,2
	A law center tap	10 % ... 18 %	20 dB ... 15 dB	0,6	0,6	0,8
		18 % ... 100 %	15 dB ... 0 dB	0,4	0,4	0,6
J 119	L log law if switch add 0,2 dB	5 % ... 10 %	40 dB ... 35 dB	1	1,2	1,5
		10 % ... 15 %	35 dB ... 30 dB	0,6	0,8	1
		15 % ... 50 %	30 dB ... 20 dB	0,4	0,8	1,5
		50 % ... 62 %	20 dB ... 15 dB	0,8	1,2	1,5
		62 % ... 100 %	15 dB ... 0 dB	0,4	0,8	1,5
	F log law + switch	2,5 % ... 5 %	26 dB ... 20 dB	1,6	2	2,4
		5 % ... 8 %	20 dB ... 15 dB	0,8	1,2	1,6
		8 % ... 15 %	15 dB ... 10 dB	0,6	0,8	1
		15 % ... 100 %	10 dB ... 0 dB	0,4	0,8	1
	W log law	4 % ... 14 %	30 dB ... 25 dB	1	1,2	1,6
14 % ... 100 %		25 dB ... 0 dB	0,4	0,4	0,6	
S law	35 % ... 63 %	15 dB ... 2 dB	0,6	0,8	1	
J 159	Add 0,7 dB to these values					

OPTIONS

MODULES: RS on/off SWITCH

RSI changeover SWITCH

The position of each module is free.

RS and RSI rotary switches are housed in a standard P11 module size 12,7 x 12,7 x 5,08 mm³ (.5" x .5" x .2"). They have the same terminal styles as the assembled electrical modules.

CAUTION : Because of the switch actuation travel, the potentiometer total electrical travel is reduced to 240° ± 10°.

Switch actuation is described as seen from the shaft end.

D: means actuation in maximum CCW position

F: means actuation in maximum CW position

The switch actuation travel is 25° with a total mechanical travel of 300° ± 5°.

MODULES :

PUSH/PUSH SWITCH RSPP

MOMENTARY/PUSH SWITCH RSMP

The switches are manufactured by ITT, F.U. series (NE18 series available on request).

They have to be the last element of potentiometer and are linked to electrical module by an interface.

RSPP and RSMP switches are available only with P11/PA11 T-Q or 7 series not with P11/PA11 V or 2 series.

Options :

2 reversing switches F2 4 reversing switches F4

6 reversing switches F6 8 reversing switches F8

Available with shafts R(T), G (Q), CR (7) others shafts on request.

Not available with panel sealed option.

Number of modules before the switch limited to 3 modules.

RSD SINGLE POLE SWITCH, NORMALLY OPEN

In full CCW position, the contact between 1 and 3 is open. It is made at the beginning of the travel in CW direction.

RSF SINGLE POLE SWITCH, NORMALLY OPEN

In full CW position, the contact between 1 and 3 is open. It is made at the beginning of the travel in CCW direction.

RSID SINGLE POLE CHANGEOVER

In full CCW position, the contact is made between 3 and 2 and open between 3 and 1. Switch actuation (CW direction) reverses these positions.

RSIF SINGLE POLE CHANGEOVER

In full CW position, the contact is made between 1 and 2 and open between 1 and 3. Switch actuation (CCW direction) reverses these positions.

RSPP F2 : PUSH/PUSH SWITCH WITH TWO REVERSING SWITCHES

Idle position : the contact is made between 1 and 2 and a and b. It is open between 2 and 3 and b and c.

Pushed position: the contact is made between 2 and 3 and b and c. It is open between 1 and 2 and a and b.

Not available on P11V and P11-2.

On request for P11Q and P11-7.

Table 4

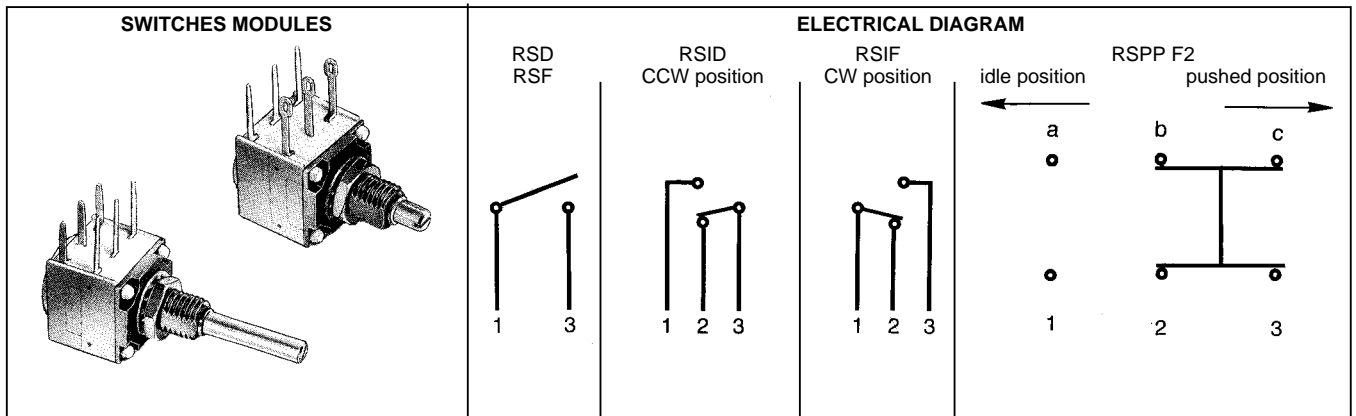

SWITCH SPECIFICATIONS

Model	RS - RSI	F2 to F8
Switching power max.	62,5 VA \pm 15 VA ∞	50 VA \pm
Switching current max.	0,25 A 250 V \pm 0,5 A 30 V ∞	0,5 A \pm
Max. current through element	2 A	2 A
Contact resistance	30 m Ω	100 m Ω
Dielectric strength	terminal to terminal	1000 V RMS
	terminal to bushing	2000 V RMS
Max. voltage operation	250 V \pm 30 V ∞	250 V \pm
Insulation resistance between contacts	10 ⁶ M Ω	10 ³ M Ω
Life at P max.	10 000 actuations	100 000 actuations
Minimal travel	25°	3,3 mm to 4,7 mm
Operating temperature	-40°C +85°C	-20°C +70°C

VALLEY DETENTS

The valley detents mechanism is housed in a standard P11 module. Up to 21 detents position available.

Count detents as follows : 1 for CCW position, 1 for full CW position, plus the other positions forming **equal resistance increments** (linear taper) - **not equal angles**.

Available now : CVID - CVIF - CVIM
CV03 - CV11 - CV21

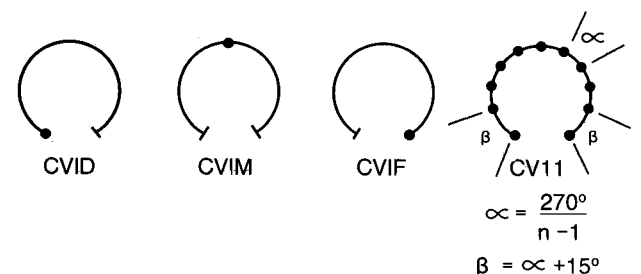
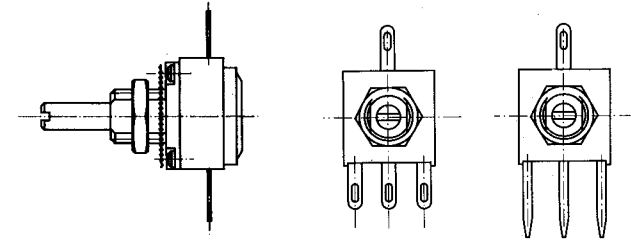

Fig. 7

CENTER TAP "J"

The extra terminal is a solder lug connected at 50% of electrical travel and situated in the potentiometer module opposite the terminals.

Center tap short circuit 11° of travel.



SHAFTS (see ordering procedure)

The shaft lengths are always measured from the mounting face.

Standard shafts are designed by a letter code (one or two digits). Shafts slots are aligned to ±10° of the wiper position.

CONCENTRIC SHAFTS

The CC or 0 or 77 concentric shaft versions allies the total flexibility of the P11/PA11 modular system to the advantage of having two separate shafts.

The outer 6 mm or 1/4" or 1/8" dia. shaft drives the modules situated immediately behind the panel, before the spacer module.

The inner 3 mm or 1/8" or .07" dia. shaft drives the modules situated after the spacer module.

Spacer is available with a choice of two spacer thickness :

5,08 mm designations : CC, 0, 77

2,54 mm designations : CC-3, 0-3, and 77-3. See page 2-59.

CUSTOM SHAFTS

When special shafts are required - flats, threaded ends, special shaft lengths, etc. a drawing is required.

SPLINED SHAFT "I"

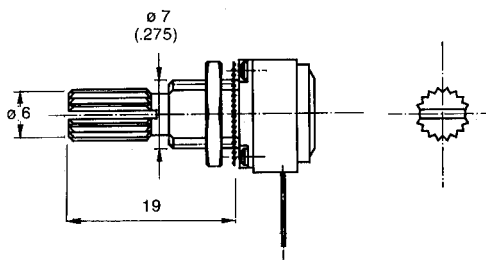

LONG LIFE APPLICATIONS 1 million cycles

P11 and PA11 single can be guaranteed for 1 000 000 mechanical cycles order ref. J131.

TRIMMERS T11 - TA11

See data sheet No. 2.413.

MARKING

Potentiometer module

SFERNICE logo, nominal ohmic value (Ω, kΩ, MΩ), two stars identify PA11 version, tolerance in % - variation law, manufacturing date (four digits), "3" for the lead 3.

Switch module

Version, manufacturing date (four digits, "c" for common lead.

Indent module

Version, manufacturing date (four digits).

OPTION : ELECTRICAL MODULE ONLY

Application : positioning transducer.

Solution : single electrical module without shaft bushing assembly.

Option : • 300° electrical travel (equal to mechanical travel)
• better linearity of variation law (taper).

Benefits : • economical
• for servo mounting, small dimensions allow use in tiny places or difficult of access.

NEUTRAL MODULE "EN"

Neutral or screen module is housed in a standard P11 module. It is used as a screen between two electrical modules. The leads can be connected to ground.

LOCATING PEGS (Anti-rotation lugs)

The locating peg is provided by a plate mounted on the bushing and positioned by the module sides.

Four set positions are available, clock face orientation : 12 3 6 9.

All P11 bushings have a double flat. When panel mounting holes have been punched accordingly, an anti-rotation logs is not necessary.

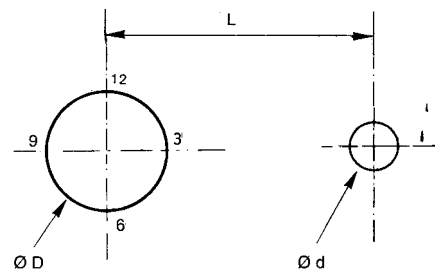

Table 6

Code	P11 - PA11					Effective high peg
	Version	T-7	V-CC	Q	2-0	
B24	øD mm	6,5 (.256)	10,5 (.413)	7,5 (.295)	10 (.394)	0,7 (.027)
	ød mm	2 (.079)	2 (.079)	2 (.079)	2 (.079)	
	L mm	6,2 (.244)	6,2 (.244)	6,2 (.244)	6,2 (.244)	
B30	ød mm	2 (.079)	2 (.079)	2 (.079)	2 (.079)	0,7 (.027)
	L mm	7,75 (.305)	7,75 (.305)	7,75 (.305)	7,75 (.305)	
B53	ød mm	-	3,5 (.138)	-	3,5 (.138)	1,1 (.043)
	L mm	-	13,5 (.531)	-	13,5 (.531)	

(inches)

MOTORIZED POTENTIOMETER

With the addition of a high quality motor, gear ratio and torque limiter module, we offer our exceptionally versatile and compact motorized unit. Ask for specific data.

ORDERING PROCEDURE

P11 Cermet element	PA11 Conductive plastic element
SERIES	
SINGLE SHAFT	
	Bushing Dia. Length Shaft Dia.
T	6 8 3
Q	7 8 4
V	10 9,5 6
2	3/8" 3/8" 1/4"
7	1/4" 1/4" 1/8"
71	1/4" 3/8" 1/8"
72	1/4" 1/2" 1/8"
CONCENTRIC SHAFT	
CC	10 9,5 3-6
O	3/8" 3/8" 1/8"-1/4"
77	1/4" 1/4" .07" - 1/8"
* All panel sealing versions have a bushing of 8 mm dia, and 8 mm length	
SHAFT AND BUSHING	

Y	Solder lugs - radial 5,08 mm (.200") pin spacing
X	PCB pins - radial
Z	PCB pins - radial with front support plate
A	PCB pins - radial with front and back support plates
W	PCB pins - axial with 2 extra pins - 1 module only
-	5,08 mm (.200") pin spacing for X, Z, W. pins section 0,9 x 0,3 mm ² (.035" x .012")
1	2,54 mm (.100") pin spacing for X, Z, W. pins section 0,6 x 0,3 mm ² (.024" x .012")
2	5,08 mm (.200") pin spacing for X, Z, W. pins section 0,6 x 0,3 mm ² (.024" x .012")
-	5,08 mm (.200") space between modules
3	7,62 mm (.300") space between modules
4	10,16 mm (.400") space between modules
TERMINAL STYLES	

B24	Distance from shaft center of 6,2 mm (.244") for all models. Plate thickness of 0,4 mm (.015").
B30	Distance from shaft center of 7,75 mm (.305") for all models. Plate thickness of 0,4 mm (.015").
B53	Distance from shaft center of 13,5 mm (.531") for V, 2, CC and O models. Plate thickness of 0,8 mm (.031").
Locating pegs can be placed at 12, 3, 6 or 9 o'clocks. Not available with panel and shaft sealing option P.	
LOCATING PEGS	

P All panel sealing versions have a bushing of 8 mm dia. and 8 mm length. The shaft K - M - E - CK - CM - CD - CH are not standard.

PANEL-SHAFT SEALING

OPTION

FROM MOUNTING FACE			
T	K M R	Dia. Length	End shaft
		3 9,5	} slotted
		3 12,5	
		3 22	
Q	E F G I	4 9,5 4 12,5 4 22 6 19	} slotted
		6 19	
V	D N S	6 16 6 25 6 50	} slotted
		6 25	
		6 50	
AP		Custom - specify or quote drawing.	
7	CK	Dia. Length 1/8" 3/8"	} slotted
7-71	CM	1/8" 1/2"	
71	CD	1/8" 5/8"	} slotted
72	CR	1/8" 3/4"	
		1/8" 7/8"	
2	VD VR VN VL	1/4" 5/8" 1/4" 7/8" 1/4" 1" 1/4" 1.1/2"	} slotted
		1/4" 5/8"	
		1/4" 7/8"	
		1/4" 1"	
CC	D U	6 16 3 28,5	} plain
CC-3			
77	CM CR	1/8" 1/2" .07" .874"	} plain
77-3			
O	VD VU	1/4" 5/8" 1/8" 9/8"	} plain
O-3			
STANDARDS SHAFT LENGTHS			

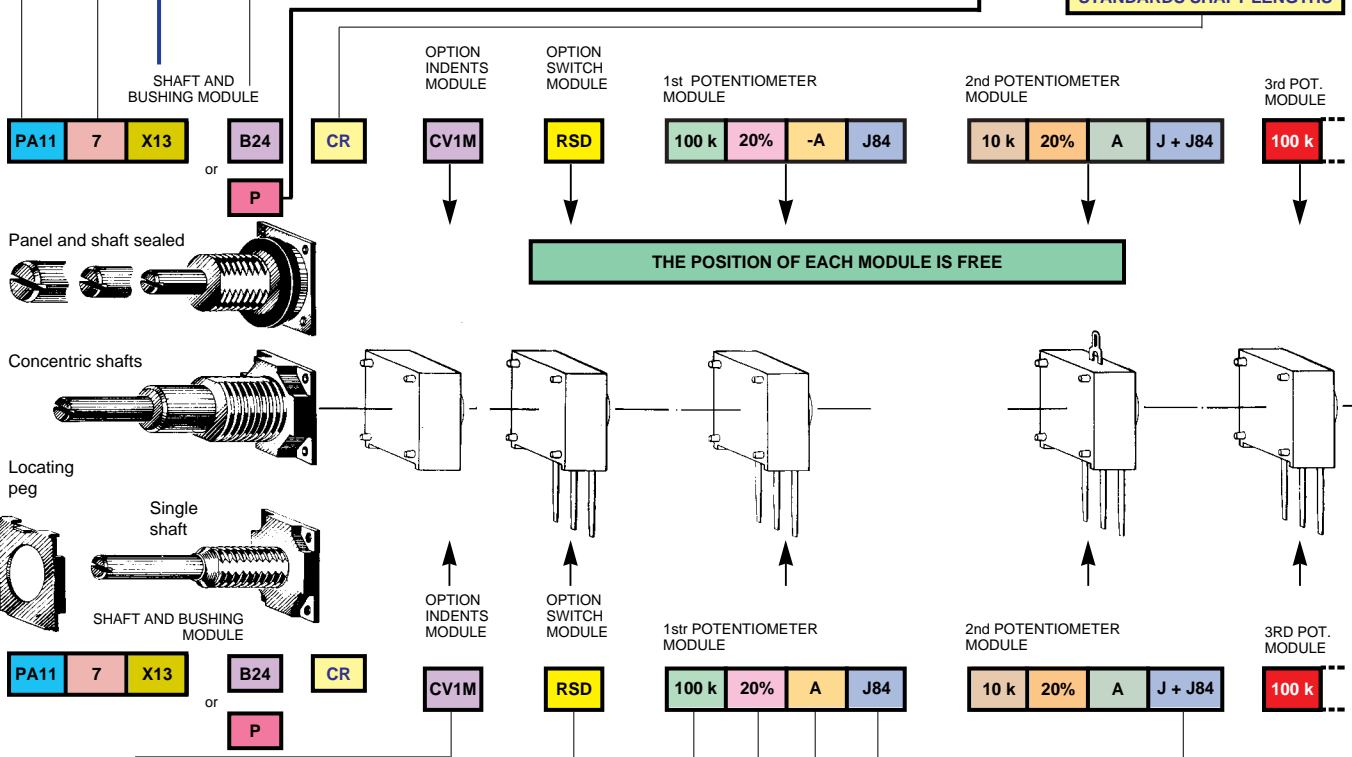

OPTION	
INDENT MODULE	
CV1M	1 indent at half travel
CV1D	1 indent CCW position
CV1F	1 indent CW position
CV03	3 indents inc. CW & CCW
-	-
-	-
-	-
-	-
-	-
-	-
-	-
-	-
-	-
CV21	21 indents etc.
Former CRN version (N-1 equal mechanical angles) available on request.	

OPTION	
SWITCH MODULE	
RSD	Single pole open switch in CCW position - 2 pins
RSF	Single pole open switch in CW position - 2 pins
RSID	Single pole chargeover switch in CCW position - 3 pins
RSIF	Single pole chargeover switch in CW position - 3 pins
An assembly can comprise 1 or more switch modules. Pin out RS and RSI is the pin out as other assembled modules.	

OHMIC VALUE	
Quote in clear use multipliers K - M	
22 Ω to 4,7 MΩ	
A linear law - cermet	
470 Ω to 1 MΩ	
L, F, S non linear laws cermet	
470 Ω to 2,2 MΩ	
A linear law conductive plastic	

VARIATION LAW	
A	Linear
L	CW log 10 %
F	CW reverse log
S	Audio S shape symmetrical log
W	CW log 20%
RL	CCW log

TOLERANCE	
±20 %	Standard
±10 %	Optional
±5 %	Optional (cermet only)

OPTIONS	
LC	Low current
J	Center tap
J41	Panel sealed bushing 10 mm dia.
J44	Interlinearity 2 % (linear law)
J84	Accuracy of center point of CV1M to ±2 % (except S law)
J116	Interlinearity 0,4 dB linear taper
J119	Interconformity 0,8 dB non linear taper
J123	Linearity ± 3 % (linear law)
J131	1.000.000 mechanical cycles
J145	Linearity ±2 % (linear law)
J152	Marking part number
J159	Interlinearity 1,5 dB non linear taper
EN	Empty module with screen
EV	Empty module without pin
M	Motorized assembly
RSPP	Push Push switch
RSMP	Momentary Push switch
Servo	Electrical travel 300°

Standard assemblies can comprise up to 7 modules, in addition to the shaft and bushing assembly.