

High dielectric strength
High peak-current capability
Especially suitable for snubber circuits

Construction

- Self-healing
- Plastic dielectric
- Oil-impregnated tubular windings (no PCB)
- Metal-sprayed end faces ensure reliable contacting
- Cylindrical aluminum case
- 1-pole version, ceramic lead-through
- Mounting bolts M8 or M12

Terminals

- Tab connector 6,3 mm

Mounting parts

- If the vibration stress is $\leq 5 g$ the bolt is used for mounting.
- In case of a vibration stress $> 5 g$ refer to chapter "Mounting parts".

Grounding

- 1-pole capacitors need not be grounded.

Overpressure disconnecter (mechanical)

When the overpressure disconnecter responds, the capacitor extends by up to 8 mm.

So leave sufficient space above the terminals when mounting the capacitor.

Individual data sheets

Individual capacitors of this series are specified in detail (incl. thermal data) [on pages 174 ... 185](#).

Upon request, these data sheets are available for each capacitor type.



Technical data

Standards		IEC 1071-1/2 EN 61071-1/2 VDE 0560 part 120 and 121
Dielectric dissipation factor	$\tan \delta_0$	$2 \cdot 10^{-4}$
Max. repetitive rate of voltage rise	$(du/dt)_{\max}$	$\frac{\hat{i}}{C}$
Max. non-repetitive rate of voltage rise	$(du/dt)_s$	$\frac{I_s}{C}$
Climatic data:		
Min. operating temperature	Θ_{\min}	- 25 °C
Max. operating temperature	Θ_{\max}	+ 85 °C
Average relative humidity		≤ 95 %
Failure quota	$\alpha_{FQ(\text{co})}$	300 failures per 10 ⁹ component hours
Load duration	$t_{LD(\text{co})}$	100 000 h
Storage temperature limit	Θ_{stg}	- 55/+ 85 °C
IEC climatic category (IEC 68-1 and 2)		25/085/56
Test A, cold		- 25 °C
Test B, dry heat		+ 85 °C
Test Ca, damp heat, steady state		56 days/40 °C/93 % rel. humidity
Values after test Ca:		
Capacitance change	$\Delta C/C$	≤ 1 %
Insulation resistance	R_{is}	$C_N \leq 1 \mu\text{F}: \geq 10\,000 \text{ M}\Omega$
Self-discharge time constant $\tau =$	$R_{\text{is}} \cdot C$	$C_N > 1 \mu\text{F}: \geq 10\,000 \text{ s}$
Dissipation factor change	$\Delta \tan \delta$	≤ 1 · 10 ⁻⁴
Test data:		
AC test voltage between terminals	U_{TT}	1,25 · U_N , 50 Hz, 10 s (or DC 1,75 · U_N , 10 s)
Insulation resistance	R_{is}	$C_N \leq 1 \mu\text{F}: \geq 10\,000 \text{ M}\Omega$
Self-discharge time constant $\tau =$	$R_{\text{is}} \cdot C$	$C_N > 1 \mu\text{F}: \geq 10\,000 \text{ s}$
Dissipation factor (50 Hz)	$\tan \delta$	≤ 3 · 10 ⁻⁴

B 25 835

Damping

Available ratings

U_N (V)	AC	900	1400	1700	2100	3400	
C_R (μ F)							
0,10							
0,15							
0,22							
0,33							
0,47							
0,68							
1,0							
1,5							
2,2							
3,3							
4,7							

Data book range

Upon request

Characteristics and ordering codes

$C_N^{1)}$ μF	I_{\max} A	\hat{i} A	I_s A	R_S 20 °C mΩ	L_{self} nH	Dimensions $d \times l$ mm	Fig.	Appr. weight g	Ordering code	Pg.
$U_N = \text{AC } 900 \text{ V}$ $\hat{u} = 1100 \text{ V}$ $u_s = 1500 \text{ V}$ $U_{\text{TT}} = \text{AC } 1150 \text{ V}, 10 \text{ s}$										
0,22	10	90	220	15,0	110	25 × 57	1	40	B25835-M6224-K007	174
0,33	10	130	330	11,0	110	25 × 57	1	40	B25835-M6334-K007	
0,47	10	100	250	19,0	110	25 × 57	1	40	B25835-M6474-K007	
0,68	18	150	370	14,0	110	30 × 57	1	50	B25835-M6684-K007	
1,00	18	220	550	10,0	110	30 × 57	1	50	B25835-M6105-K007	
2,20	18	480	1200	6,6	110	45 × 57	1	110	B25835-M6225-K007	
4,70	18	1000	2500	4,6	110	60 × 57	1	190	B25835-M6475-K007	
$U_N = \text{AC } 1400 \text{ V}$ $\hat{u} = 1800 \text{ V}$ $u_s = 2400 \text{ V}$ $U_{\text{TT}} = \text{AC } 1800 \text{ V}, 10 \text{ s}$										
0,10	10	150	380	20,0	110	25 × 57	2	40	B25835-M0104-K007	176
0,22	10	220	550	18,0	140	25 × 70	1	50	B25835-M0224-K007	
0,33	10	200	500	27,0	190	25 × 95	1	60	B25835-M0334-K007	
0,47	18	280	700	20,0	190	30 × 95	1	90	B25835-M0474-K007	
0,68	18	400	1000	15,0	190	30 × 95	1	90	B25835-M0684-K007	
1,00	18	600	1500	12,0	190	35 × 95	1	110	B25835-M0105-K007	
2,20	18	1300	3300	7,6	190	50 × 95	1	220	B25835-M0225-K007	
$U_N = \text{AC } 1700 \text{ V}$ $\hat{u} = 2100 \text{ V}$ $u_s = 2900 \text{ V}$ $U_{\text{TT}} = \text{AC } 2100 \text{ V}, 10 \text{ s}$										
0,10	10	200	500	16,0	110	25 × 57	2	40	B25835-M7104-K007	178
0,22	10	300	750	15,0	140	25 × 70	1	50	B25835-M7224-K007	
0,47	18	660	1600	8,4	140	35 × 70	1	90	B25835-M7474-K007	

1) Capacitance tolerance ± 10 %

B 25 835

Damping

Characteristics and ordering codes

$C_N^{1)}$	I_{\max}	\hat{i}	I_s	R_S 20 °C	L_{self}	Dimensions $d \times l$	Fig.	Appr. weight	Ordering code	Pg.
μF	A	A	A	m Ω	nH	mm		g		
$U_N = \text{AC } 2100 \text{ V}$										
			$\hat{u} = 2600 \text{ V}$			$u_s = 3600 \text{ V}$			$U_{TT} = \text{AC } 2600 \text{ V}, 10 \text{ s}$	
0,47	18	750	1900	11,0	190	35 × 95	2	110	B25835-M1474-K007	
0,68	18	1100	2700	8,7	190	40 × 95	1	140	B25835-M1684-K007	
1,00	18	1600	4000	7,1	190	45 × 95	1	180	B25835-M1105-K007	180
2,20	18	1100	2800	13,0	250	60 × 131	1	440	B25835-M1225-K007	
$U_N = \text{AC } 3400 \text{ V}$										
			$\hat{u} = 4300 \text{ V}$			$u_s = 5800 \text{ V}$			$U_{TT} = \text{AC } 4300 \text{ V}, 10 \text{ s}$	
0,10	18	280	700	33,0	250	35 × 131	1	150	B25835-M2104-K007	182
0,15	18	400	1000	24,0	250	35 × 131	1	150	B25835-M2154-K007	
0,22	18	600	1500	18,0	250	35 × 131	1	150	B25835-M2224-K007	
0,33	18	900	2300	15,0	250	50 × 131	1	300	B25835-M2334-K007	
0,47	18	1300	3300	12,0	250	50 × 131	1	300	B25835-M2474-K007	
0,68	18	1900	4800	11,0	250	60 × 131	1	440	B25835-M2684-K007	184

1) Capacitance tolerance $\pm 10 \%$

Dimensional drawing

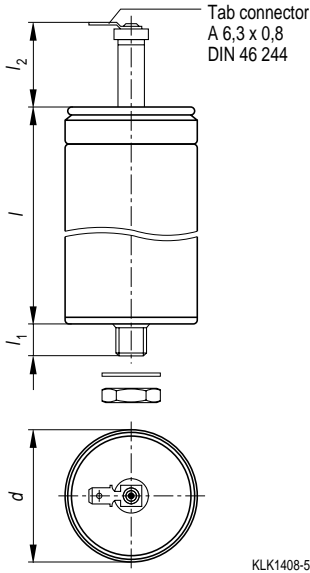

$d^{+0,5}_{-0,2}$	l^{+1}_{-2}	$l_1 + 1^*$	l_{2max}	Creepage distance	Clearance
mm	mm	mm	mm	mm	mm

Figure 1

25	57	8	15	6	6
25	70	8	23	14	14
25	95	8	23	14	14
30	57	8	15	6	6
30	95	8	23	14	14
35	70	8	26	14	14
35	95	8	26	14	14
35	131	8	32	20	20
40	95	8	32	20	20
45	57	8	22	10	10
45	95	8	32	20	20
50	95	12	26	14	14
50	131	12	32	20	20
60	57	12	22	10	10
60	131	12	32	20	20

Figure 2

25	57	8	23	14	14
35	95	8	32	20	20

- *) 8 mm = threaded bolt M8
12 mm = threaded bolt M12

Mounting parts (included in delivery)

Threaded bolt	Max. torque	Washer	Hex nut
M8	4 Nm	A 8,4 DIN 125-Ms	M 8 ISO 4035
M12	10 Nm	A13 DIN 125-Ms	M12 ISO 4035

B 25 835

Damping

0,68 μF / 900 Vac

Ordering code: B25835-M6684-K007

Characteristics

C_N , tol.	0,68 $\mu\text{F} \pm 10\%$
U_N	AC 900 V
I_{max}	18 A
L_{self}	110 nH
$\tan \delta_0$	$2 \cdot 10^{-4}$
R_S	14 m Ω

Maximum ratings

\hat{u}	1100 V
u_s	1500 V
\hat{i}	150 A
I_s	370 A
$(du/dt)_{\text{max}}$	220 V/ μs
$(du/dt)_s$	550 V/ μs

Test data

U_{TT}	AC 1150 V, 10 s
R_{is}	$\geq 10000 \text{ M}\Omega$
$\tan \delta$ (50 Hz)	$\leq 3 \cdot 10^{-4}$

Climatic data

Θ_{min}	- 25 °C
Θ_{max}	+ 85 °C
Humidity	Average relative humidity $\leq 95\%$
$\alpha_{\text{FQ(co)}}$	300/10 ⁹ h
$t_{\text{LD(co)}}$	100000 h
Θ_{stg}	- 55 to + 85 °C

IEC climatic category: 25/085/56

(IEC 68-1 and 2)

Θ_{test}	+ 40 °C
Rel. humidity	93 %
t_{test}	56 days
$\Delta C/C$	$\leq 1\%$
$\Delta \tan \delta$	$\leq 1 \cdot 10^{-4}$
R_{is}	$\geq 10000 \text{ M}\Omega$

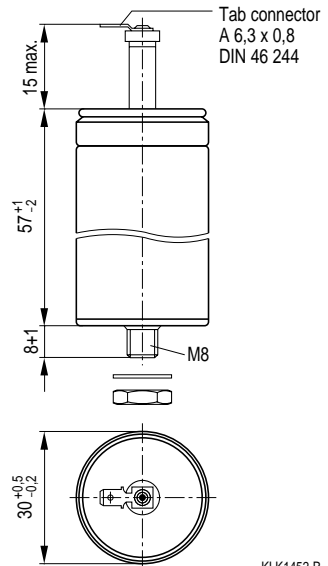

Design data

Dimensions $\varnothing \times l$	30 mm \times 57 mm
Approx. weight	50 g
Impregnation	Oil
Fixing	Threaded bolt M8
Mounting hole	9,5 mm
Max. torque	4 Nm
Terminals	Tab connector 6,3 mm
Terminal cross section	1,5 mm ²
Creepage distance	6 mm
Clearance	6 mm
Overpressure disconnector	

Thermal data

B25835-M6684-K007

Dielectric power dissipation P_D
versus repetition frequency f_0

$\hat{u}_{ac} = 900 \text{ V}$ —————
 $\hat{u}_{ac} = 810 \text{ V}$ - - - - -

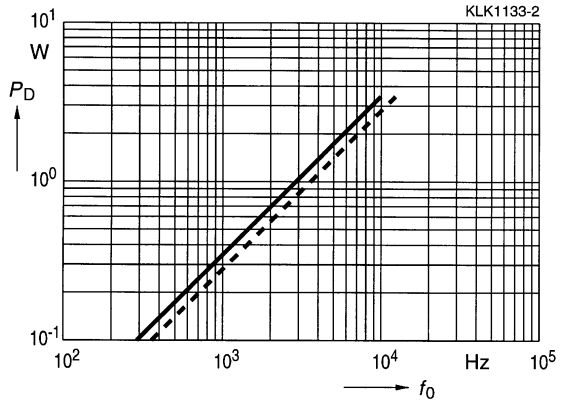

Ohmic power dissipation P_R
versus rms current value I

$R_S (85^\circ\text{C}) = 18 \text{ m}\Omega$

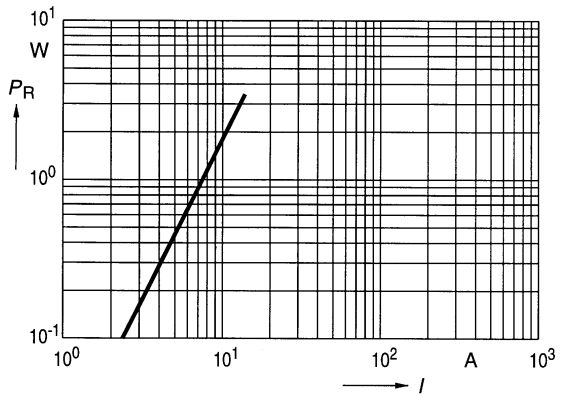

Permissible ambient temperature Θ_A
versus total power dissipation P
(Upright mounting position)

Natural cooling —————
Forced cooling 2 m/s - - - - -
Permissible capacitor
temperature - · - · -

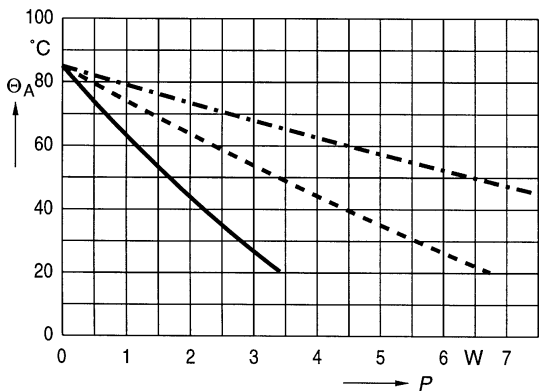

B 25 835

Damping

2,2 μF / 1400 Vac

Ordering code: B25835-M0225-K007

Characteristics

C_N , tol.	2,2 $\mu\text{F} \pm 10\%$
U_N	AC 1400 V
I_{max}	18 A
L_{self}	190 nH
$\tan \delta_0$	$2 \cdot 10^{-4}$
R_S	7,6 m Ω

Maximum ratings

\hat{u}	1800 V
u_s	2400 V
\hat{i}	1,3 kA
I_s	3,3 kA
$(du/dt)_{\text{max}}$	600 V/ μs
$(du/dt)_s$	1500 V/ μs

Test data

U_{TT}	AC 1800 V, 10 s
$R_{is} \cdot C$	≥ 10000 s
$\tan \delta$ (50 Hz)	$\leq 3 \cdot 10^{-4}$

Climatic data

Θ_{min}	- 25 °C
Θ_{max}	+ 85 °C
Humidity	Average relative humidity $\leq 95\%$
$\alpha_{\text{FQ}(\text{co})}$	300/10 ⁹ h
$t_{\text{LD}(\text{co})}$	100000 h
Θ_{stg}	- 55 to + 85 °C

IEC climatic category: 25/085/56

(IEC 68-1 and 2)

Θ_{test}	+ 40 °C
Rel. humidity	93 %
t_{test}	56 days
$\Delta C/C$	$\leq 1\%$
$\Delta \tan \delta$	$\leq 1 \cdot 10^{-4}$
$R_{is} \cdot C$	≥ 10000 s

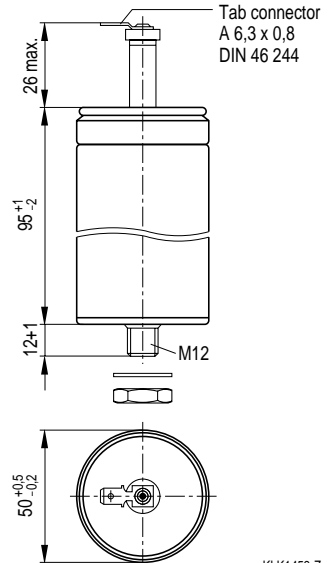

KLK1453-Z

Design data

Dimensions $\varnothing \times l$	50 mm \times 95 mm
Approx. weight	220 g
Impregnation	Oil
Fixing	Threaded bolt M12
Mounting hole	14 mm
Max. torque	10 Nm
Terminals	Tab connector 6,3 mm
Terminal cross section	1,5 mm ²
Creepage distance	14 mm
Clearance	14 mm
Overpressure disconnecter	

Thermal data

B25835-M0225-K007

Dielectric power dissipation P_D
versus repetition frequency f_0

$\hat{u}_{ac} = 1400 \text{ V}$ —————
 $\hat{u}_{ac} = 1260 \text{ V}$ - - - - -

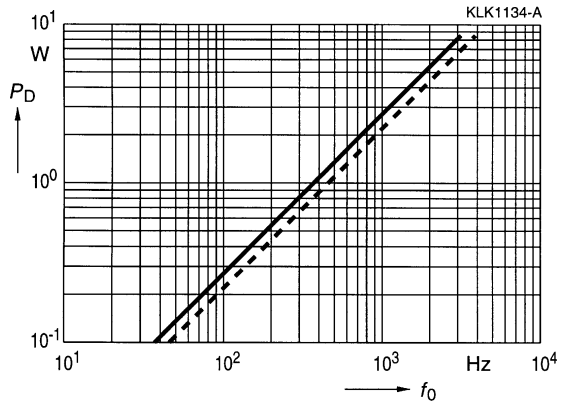

Ohmic power dissipation P_R
versus rms current value I

$R_S (85^\circ\text{C}) = 9,3 \text{ m}\Omega$

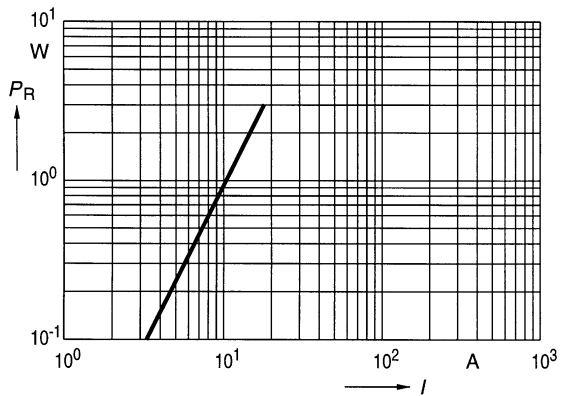

Permissible ambient temperature Θ_A
versus total power dissipation P
(Upright mounting position)

Natural cooling —————
Forced cooling 2 m/s - - - - -
Permissible capacitor
temperature - - - - -

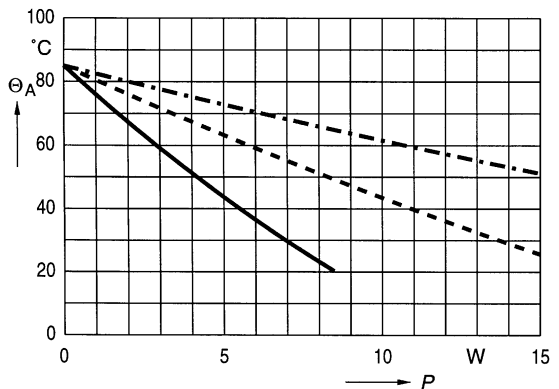

B 25 835

Damping

0,1 μF / 1700 Vac

Ordering code: B25835-M7104-K007

Characteristics

C_N , tol.	0,1 $\mu\text{F} \pm 10\%$
U_N	AC 1700 V
I_{max}	10 A
L_{self}	110 nH
$\tan \delta_0$	$2 \cdot 10^{-4}$
R_S	16 m Ω

Maximum ratings

\hat{u}	2100 V
u_s	2900 V
\hat{i}	200 A
I_s	500 A
$(du/dt)_{\text{max}}$	2000 V/ μs
$(du/dt)_s$	5000 V/ μs

Test data

U_{TT}	AC 2100 V, 10 s
R_{is}	$\geq 10000 \text{ M}\Omega$
$\tan \delta$ (50 Hz)	$\leq 3 \cdot 10^{-4}$

Climatic data

Θ_{min}	- 25 °C
Θ_{max}	+ 85 °C
Humidity	Average relative humidity $\leq 95\%$
$\alpha_{\text{FQ(co)}}$	300/10 ⁹ h
$t_{\text{LD(co)}}$	100000 h
Θ_{stg}	- 55 to + 85 °C

IEC climatic category: 25/085/56

(IEC 68-1 and 2)

Θ_{test}	+ 40 °C
Rel. humidity	93 %
t_{test}	56 days
$\Delta C/C$	$\leq 1\%$
$\Delta \tan \delta$	$\leq 1 \cdot 10^{-4}$
R_{is}	$\geq 10000 \text{ M}\Omega$

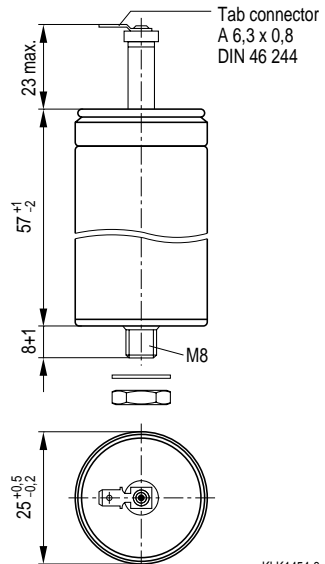

KLK1454-8

Design data

Dimensions $\varnothing \times l$	25 mm \times 57 mm
Approx. weight	40 g
Impregnation	Oil
Fixing	Threaded bolt M8
Mounting hole	9,5 mm
Max. torque	4 Nm
Terminals	Tab connector 6,3 mm
Terminal cross section	0,75 mm ²
Creepage distance	14 mm
Clearance	14 mm
Overpressure disconnector	

Thermal data

B25835-M7104-K007

Dielectric power dissipation P_D
versus repetition frequency f_0

$\hat{u}_{ac} = 1700 \text{ V}$ —————
 $\hat{u}_{ac} = 1530 \text{ V}$ - - - - -

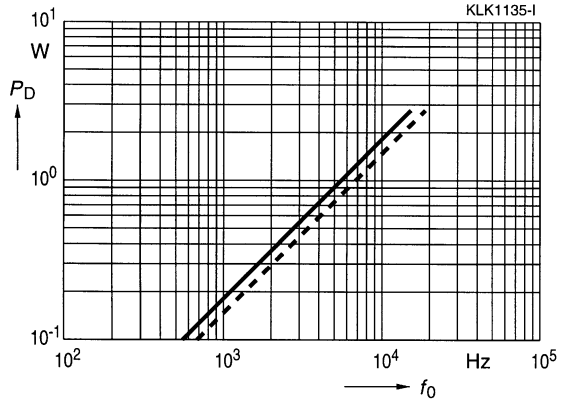

Ohmic power dissipation P_R
versus rms current value I

$R_S (85^\circ\text{C}) = 20 \text{ m}\Omega$

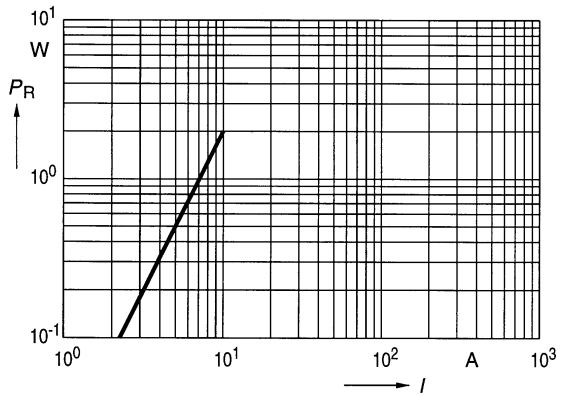

Permissible ambient temperature Θ_A
versus total power dissipation P
(Upright mounting position)

Natural cooling —————
Forced cooling 2 m/s - - - - -
Permissible capacitor
temperature - - - - -

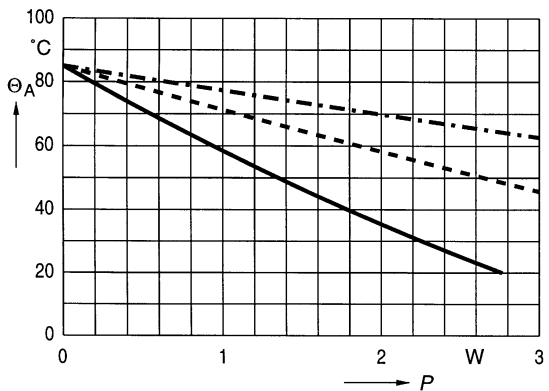

B 25 835

Damping

1 μF / 2100 Vac

Ordering code: B25835-M1105-K007

Characteristics

C_N , tol.	1 $\mu\text{F} \pm 10\%$
U_N	AC 2100 V
I_{max}	18 A
L_{self}	190 nH
$\tan \delta_0$	$2 \cdot 10^{-4}$
R_S	7,1 m Ω

Maximum ratings

\hat{u}	2600 V
u_s	3600 V
\hat{i}	1,6 kA
I_s	4,0 kA
$(du/dt)_{\text{max}}$	1600 V/ μs
$(du/dt)_s$	4000 V/ μs

Test data

U_{TT}	AC 2600 V, 10 s
R_{is}	$\geq 10000 \text{ M}\Omega$
$\tan \delta$ (50 Hz)	$\leq 3 \cdot 10^{-4}$

Climatic data

Θ_{min}	- 25 °C
Θ_{max}	+ 85 °C
Humidity	Average relative humidity $\leq 95\%$
$\alpha_{\text{FQ}(\text{co})}$	300/10 ⁹ h
$t_{\text{LD}(\text{co})}$	100000 h
Θ_{stg}	- 55 to + 85 °C

IEC climatic category: 25/085/56

(IEC 68-1 and 2)

Θ_{test}	+ 40 °C
Rel. humidity	93 %
t_{test}	56 days
$\Delta C/C$	$\leq 1\%$
$\Delta \tan \delta$	$\leq 1 \cdot 10^{-4}$
R_{is}	$\geq 10000 \text{ M}\Omega$

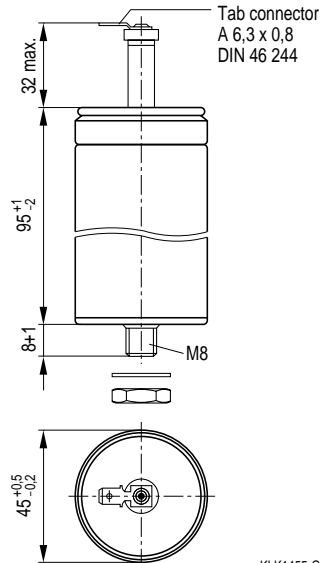

KLK1455-G

Design data

Dimensions $\varnothing \times l$	45 mm \times 95 mm
Approx. weight	180 g
Impregnation	Oil
Fixing	Threaded bolt M8
Mounting hole	9,5 mm
Max. torque	4 Nm
Terminals	Tab connector 6,3 mm
Terminal cross section	1,5 mm ²
Creepage distance	20 mm
Clearance	20 mm
Overpressure disconnector	

Thermal data

B25835-M1105-K007

Dielectric power dissipation P_D
versus repetition frequency f_0

$\hat{u}_{ac} = 2100 \text{ V}$ —————
 $\hat{u}_{ac} = 1890 \text{ V}$ - - - - -

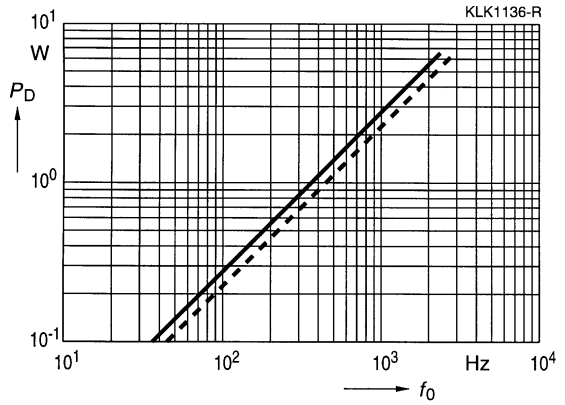

Ohmic power dissipation P_R
versus rms current value I

$R_S (85^\circ\text{C}) = 8,8 \text{ m}\Omega$

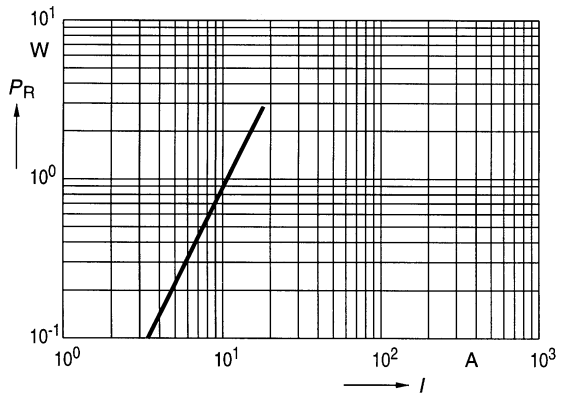

Permissible ambient temperature Θ_A
versus total power dissipation P
(Upright mounting position)

Natural cooling —————
Forced cooling 2 m/s - - - - -
Permissible capacitor
temperature - - - - -

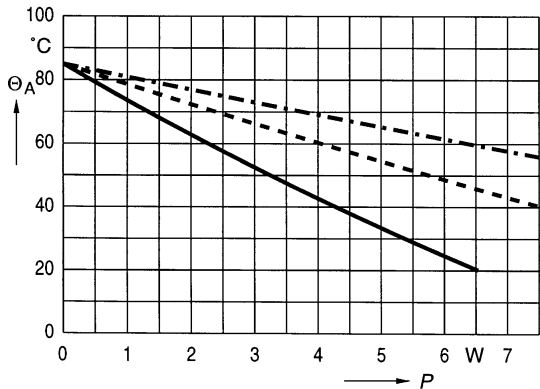

B 25 835

Damping

0,1 μF / 3400 Vac

Ordering code: B25835-M2104-K007

Characteristics

C_N , tol.	0,1 $\mu\text{F} \pm 10\%$
U_N	AC 3400 V
I_{max}	18 A
L_{self}	250 nH
$\tan \delta_0$	$2 \cdot 10^{-4}$
R_S	33 m Ω

Maximum ratings

\hat{u}	4300 V
u_s	5800 V
\hat{i}	280 A
I_s	700 A
$(du/dt)_{\text{max}}$	2800 V/ μs
$(du/dt)_s$	7000 V/ μs

Test data

U_{TT}	AC 4300 V, 10 s
R_{is}	$\geq 10000 \text{ M}\Omega$
$\tan \delta$ (50 Hz)	$\leq 3 \cdot 10^{-4}$

Climatic data

Θ_{min}	- 25 °C
Θ_{max}	+ 85 °C
Humidity	Average relative humidity $\leq 95\%$
$\alpha_{\text{FQ(co)}}$	300/10 ⁹ h
$t_{\text{LD(co)}}$	100000 h
Θ_{stg}	- 55 to + 85 °C

IEC climatic category: 25/085/56

(IEC 68-1 and 2)

Θ_{test}	+ 40 °C
Rel. humidity	93 %
t_{test}	56 days
$\Delta C/C$	$\leq 1\%$
$\Delta \tan \delta$	$\leq 1 \cdot 10^{-4}$
R_{is}	$\geq 10000 \text{ M}\Omega$

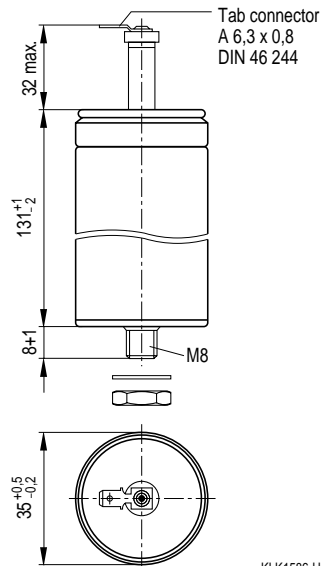

Design data

Dimensions $\varnothing \times l$	35 mm \times 131 mm
Approx. weight	150 g
Impregnation	Oil
Fixing	Threaded bolt M8
Mounting hole	10 mm
Max. torque	4 Nm
Terminals	Tab connector 6,3 mm
Terminal cross section	1,5 mm ²
Creepage distance	20 mm
Clearance	20 mm
Overpressure disconnector	

Thermal data

B25835-M2104-K007

Dielectric power dissipation P_D
versus repetition frequency f_0

$\hat{u}_{ac} = 3400 \text{ V}$ —————
 $\hat{u}_{ac} = 3060 \text{ V}$ - - - - -

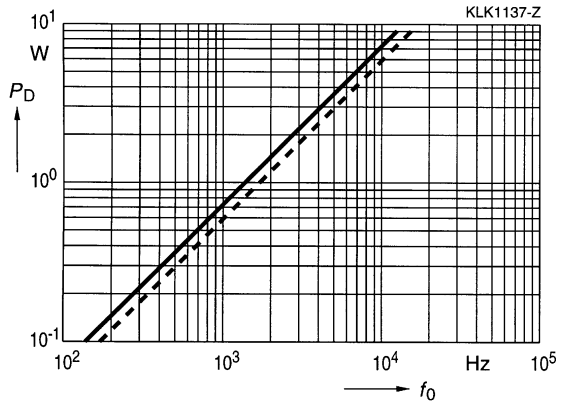

Ohmic power dissipation P_R
versus rms current value I

$R_S (85^\circ\text{C}) = 40 \text{ m}\Omega$

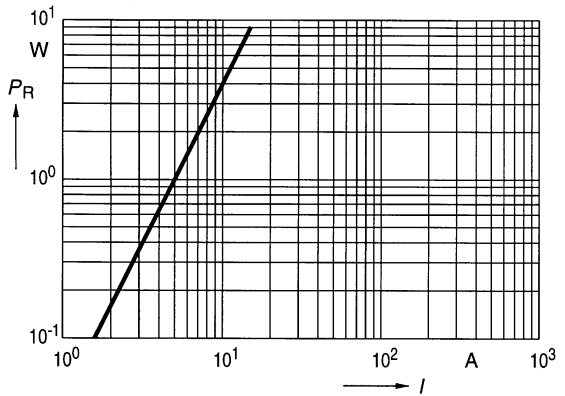

Permissible ambient temperature Θ_A
versus total power dissipation P
(Upright mounting position)

Natural cooling —————
Forced cooling 2 m/s - - - - -
Permissible capacitor
temperature - - - - -

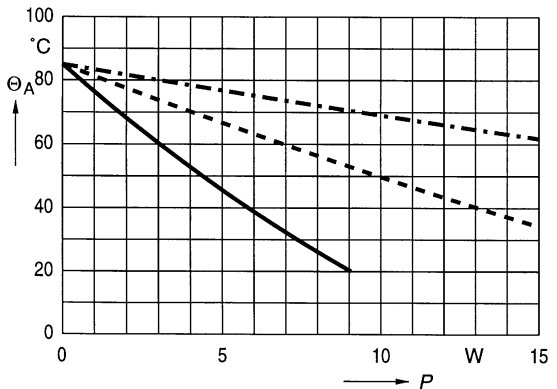

B 25 835

Damping

0,68 μF / 3400 Vac

Ordering code: B25835-M2684-K007

Characteristics

C_N , tol.	0,68 μF \pm 10 %
U_N	AC 3400 V
I_{max}	18 A
L_{self}	250 nH
$\tan \delta_0$	$2 \cdot 10^{-4}$
R_S	11 m Ω

Maximum ratings

\hat{u}	4300 V
u_s	5800 V
\hat{i}	1,9 kA
I_s	4,8 kA
$(du/dt)_{\text{max}}$	2800 V/ μs
$(du/dt)_s$	7000 V/ μs

Test data

U_{TT}	AC 4300 V, 10 s
R_{is}	$\geq 10000 \text{ M}\Omega$
$\tan \delta$ (50 Hz)	$\leq 3 \cdot 10^{-4}$

Climatic data

Θ_{min}	- 25 $^{\circ}\text{C}$
Θ_{max}	+ 85 $^{\circ}\text{C}$
Humidity	Average relative humidity $\leq 95 \%$
$\alpha_{\text{FQ}(\text{co})}$	300/10 ⁹ h
$t_{\text{LD}(\text{co})}$	100000 h
Θ_{stg}	- 55 to + 85 $^{\circ}\text{C}$

IEC climatic category: 25/085/56

(IEC 68-1 and 2)

Θ_{test}	+ 40 $^{\circ}\text{C}$
Rel. humidity	93 %
t_{test}	56 days
$\Delta C/C$	$\leq 1 \%$
$\Delta \tan \delta$	$\leq 1 \cdot 10^{-4}$
R_{is}	$\geq 10000 \text{ M}\Omega$

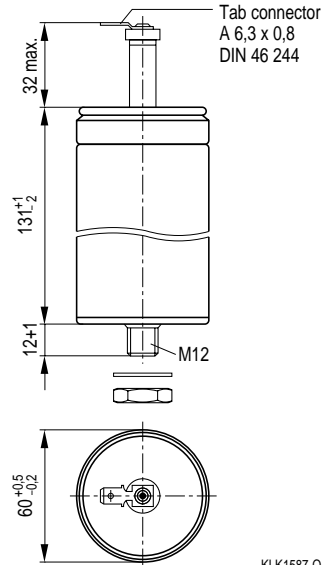

KLK1587-Q

Design data

Dimensions $\varnothing \times l$	60 mm \times 131 mm
Approx. weight	440 g
Impregnation	Oil
Fixing	Threaded bolt M12
Mounting hole	14 mm
Max. torque	10 Nm
Terminals	Tab connector 6,3 mm
Terminal cross section	1,5 mm ²
Creepage distance	20 mm
Clearance	20 mm
Overpressure disconnecter	

Thermal data

B25835-M2684-K007

Dielectric power dissipation P_D
versus repetition frequency f_0

$\hat{u}_{ac} = 3400 \text{ V}$ —————
 $\hat{u}_{ac} = 3060 \text{ V}$ - - - - -

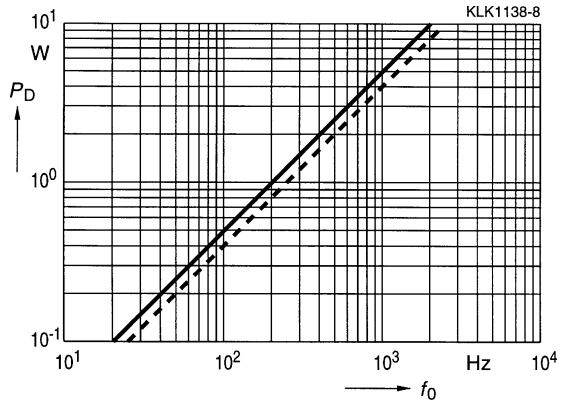

Ohmic power dissipation P_R
versus rms current value I

$R_S (85^\circ\text{C}) = 13 \text{ m}\Omega$

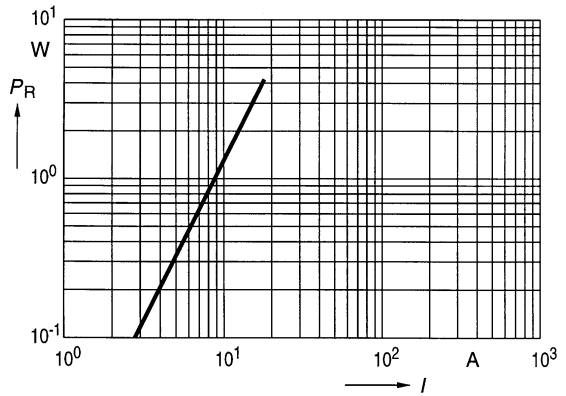

Permissible ambient temperature Θ_A
versus total power dissipation P
(Upright mounting position)

Natural cooling —————
Forced cooling 2 m/s - - - - -
Permissible capacitor
temperature - - - - -

