

3-WIRE REAL-TIME CLOCK**S-35190A**

The S-35190A is a CMOS 3-wire real-time clock IC which operates with the very low current consumption and in the wide range of operation voltage. The operation voltage is 1.3 V to 5.5 V so that this IC can be used for various power supplies from main supply to backup battery. Due to the 0.25 μ A current consumption and wide range of power supply voltage at time keeping, this IC makes the battery life longer. In the system which operates with a backup battery, the included free registers can be used as the function for user's backup memory. Users always can take back the information in the registers which is stored before power-off the main power supply, after the voltage is restored.

This IC has the function to correct advance/delay of the clock data speed, in the wide range, which is caused by the oscillation circuit's frequency deviation. Correcting according to the temperature change by combining this function and a temperature sensor, it is possible to make a high precise clock function which is not affected by the ambient temperature.

■ Features

- Low current consumption : 0.25 μ A typ. ($V_{DD} = 3.0$ V, $T_a = 25^\circ\text{C}$)
- Wide range of operating voltage : 1.3 to 5.5 V
- Built-in clock-correction function
- Built-in free user register
- 3-wire (MICROWIRE) CPU interface
- Built-in alarm interrupter
- Built-in flag generator during detection of low power voltage or at power-on
- Auto calendar up to the year 2099, automatic leap year calculation function
- Built-in constant voltage circuit
- Built-in 32.768 kHz crystal oscillator (C_d built in, C_g external)
- Package : 8-Pin SOP (JEDEC), 8-Pin TSSOP, SNT-8A
- Lead-free product

■ Applications

- Mobile game devices
- Mobile AV devices
- Digital still cameras
- Digital video cameras
- Electronic power meters
- DVD recorders
- TVs, VCRs
- Mobile phones, PHS
- Car navigation

■ Package

Package Name	Drawing Code			
	Package	Tape	Reel	Land
8-Pin SOP (JEDEC)	FJ008-A	FJ008-D	FJ008-D	–
8-Pin TSSOP	FT008-A	FT008-E	FT-008E	–
SNT-8A	PH008-A	PH008-A	PH008-A	PH008-A

■ Pin Configuration

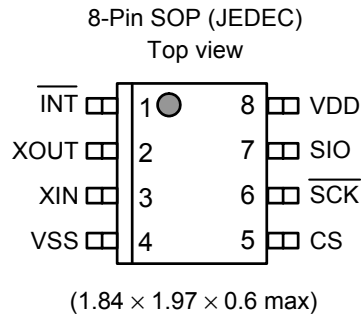

Figure 1 Pin Configuration (S-35190A-J8T1G)

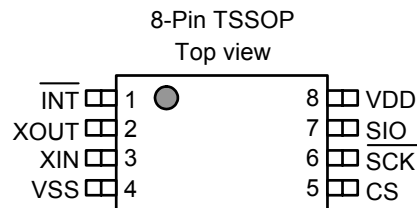

Figure 2 Pin Configuration (S-35190A-T8T1G)

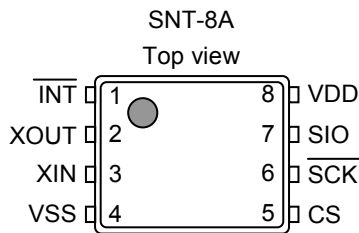

Figure 3 Pin Configuration (S-35190A-I8T1G)

■ List of Pin

Table 1

Pin No.	Symbol	Description	I/O	Configuration
1	$\overline{\text{INT}}$	Output pin for Interrupt signal	Output	Nch open-drain output (no protective diode at VDD)
2	XOUT	Connection pin for crystal oscillator	-	-
3	XIN			
4	VSS	GND pin	-	-
5	CS	Input pin for chip select	Input	CMOS input (built-in pull-down resistor. no protective diode at VDD)
6	$\overline{\text{SCK}}$	Input pin for serial clock	Input	CMOS input (no protective diode at VDD)
7	SIO	I/O pin for serial data	Bi-directional	Nch open-drain output (no protective diode at VDD) CMOS input
8	VDD	Pin for positive power supply	-	-

■ Pin Function

- CS (input for chip select) pin

This pin is to input chip select, has a pull-down resistor. Communication is available when this pin is in “H” level. If not using communication, set this pin “L” or open.

- $\overline{\text{SCK}}$ (input for serial clock) pin

This pin is to input a clock pulse for serial interface. When the CS pin is in “H”, the SIO pin inputs/outputs data by synchronizing with the clock pulse. When the CS pin is in “L” or open, the $\overline{\text{SCK}}$ pin does not accept inputting a clock pulse.

- SIO (I/O for serial data) pin

This pin is to data input/output for serial interface. When the CS pin is in “H”, the SIO pin inputs/outputs data by synchronizing with a clock pulse from the $\overline{\text{SCK}}$ pin. The status is in high impedance when the CS pin is in “L” or open, so that the S-35190A does not transmit data. Setting the CS pin to “H” level from “L” or open, this SIO pin goes in the input status so that it receives the command data. This pin has CMOS input and Nch open drain output.

- XIN, XOUT (crystal oscillator connect) pin

Connect a crystal oscillator between XIN and XOUT.

- $\overline{\text{INT}}$ (output for interrupt signal) pin

This pin outputs a signal of interrupt, or a clock pulse. By using the status register 2, users can select either of; alarm 1 interrupt, alarm 2 interrupt, output of user-set frequency, per-minute edge interrupt, minute-periodical interrupt 1, minute-periodical interrupt 2, or 32.768 kHz output. This pin has Nch open drain output.

- VDD (positive power supply) pin

Connect this VDD pin with a positive power supply. Regarding the values of voltage to be applied, refer to “■ Recommended Operation Conditions”.

- VSS pin

Connect the VSS pin to GND.

■ Equivalent Circuits of I/O Pin

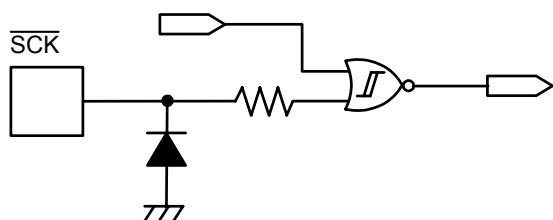

Figure 4 $\overline{\text{SCK}}$ pin

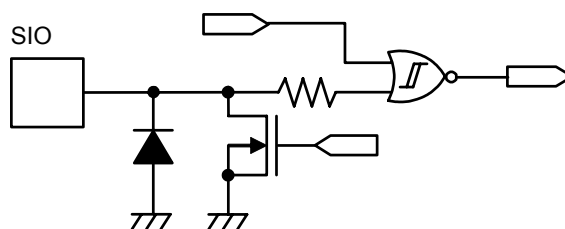

Figure 5 SIO pin

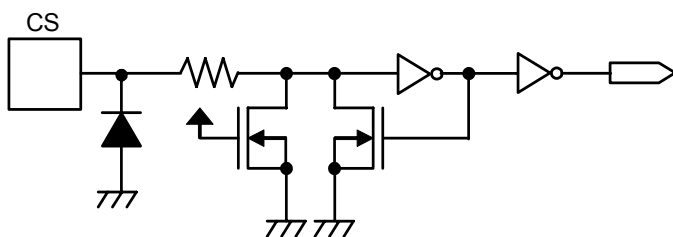

Figure 6 CS pin

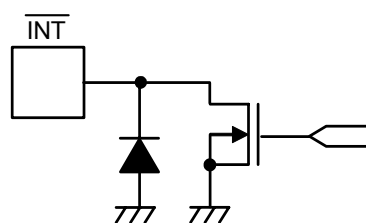

Figure 7 $\overline{\text{INT}}$ pin

■ Block Diagram

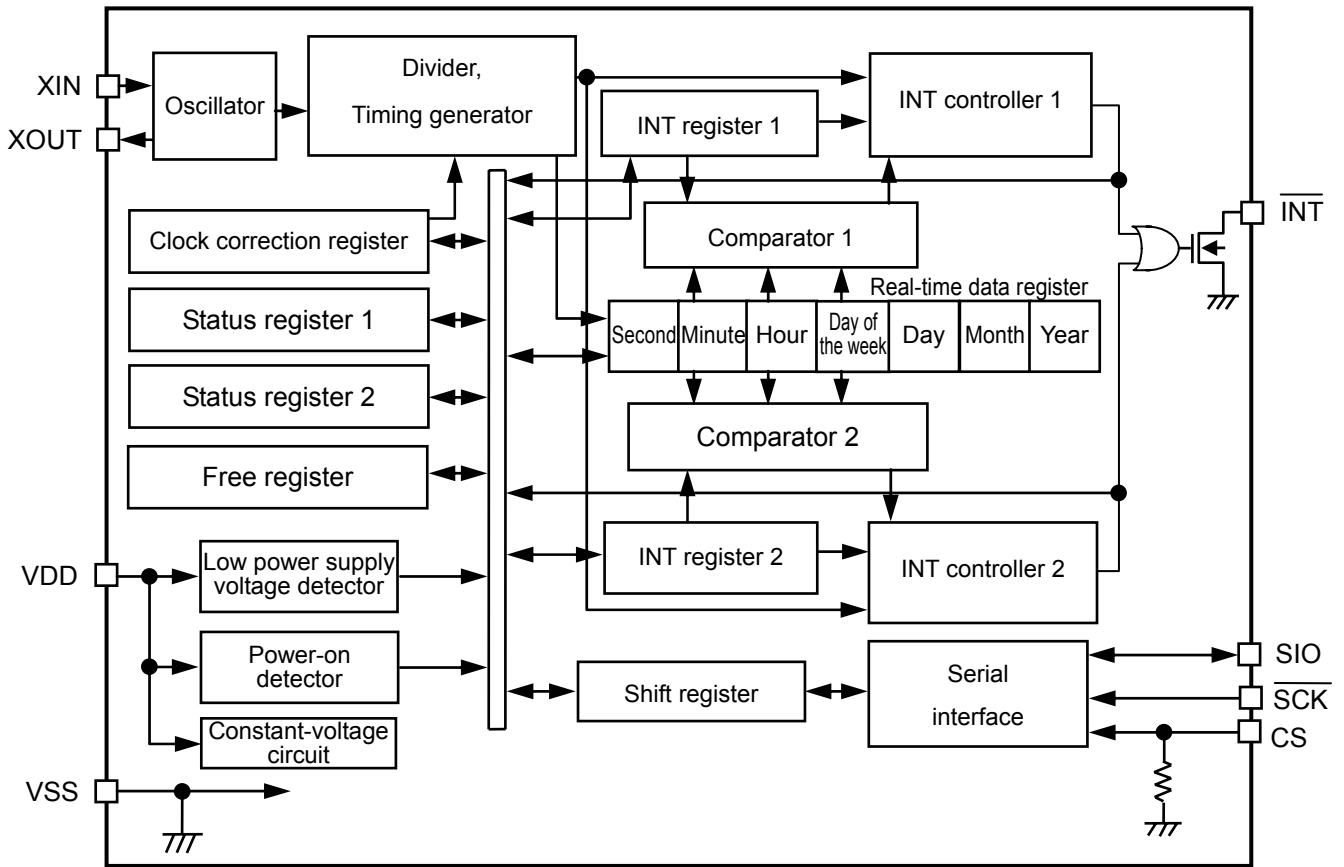

Figure 8

■ Absolute Maximum Ratings

Table 2

Parameter	Symbol	Applicable Pin	Rating	Unit
Power supply voltage	V_{DD}	–	$V_{SS} - 0.3$ to $V_{SS} + 6.5$	V
Input voltage	V_{IN}	CS, \overline{SCK} , SIO	$V_{SS} - 0.3$ to $V_{SS} + 6.5$	V
Output voltage	V_{OUT}	SIO, \overline{INT}	$V_{SS} - 0.3$ to $V_{SS} + 6.5$	V
Operating ambient temperature *1	T_{opr}	–	–40 to +85	°C
Storage temperature	T_{stg}	–	–55 to +125	°C

*1. Conditions with no condensation or frost. Condensation and frost cause short circuiting between pins, resulting in a malfunction.

Caution The absolute maximum ratings are rated values exceeding which the product could suffer physical damage. These values must therefore not be exceeded under any conditions.

■ Recommended Operation Conditions

Table 3

(V_{SS} = 0 V)

Parameter	Symbol	Conditions	Min.	Typ.	Max.	Unit
Power supply voltage *1	V_{DD}	$T_a = -40$ to $+85^\circ\text{C}$	1.3	3.0	5.5	V
Time keeping power supply voltage *2	V_{DDT}	$T_a = -40$ to $+85^\circ\text{C}$	$V_{DET} - 0.15$	–	5.5	V
Crystal oscillator C_L value	C_L	–	–	6	7	pF

*1. The power supply voltage that allows communication under the conditions shown in Table 8 of “■ AC Electrical Characteristics”.

*2. The power supply voltage that allows time keeping. For the relationship with V_{DET} (low power supply voltage detection voltage), refer to “■ Characteristics (Typical Data)”.

■ Oscillation Characteristics

Table 4

(T_a = 25°C, V_{DD} = 3.0 V, V_{SS} = 0 V, VT-200 crystal oscillator (C_L = 6 pF, 32.768 kHz) manufactured by Seiko Instruments Inc.)

Parameter	Symbol	Conditions	Min.	Typ.	Max.	Unit
Oscillation start voltage	V_{STA}	Within 10 seconds	1.1	–	5.5	V
Oscillation start time	t_{STA}	–	–	–	1	s
IC-to-IC frequency deviation *1	δIC	–	–10	–	+10	ppm
Frequency voltage deviation	δV	$V_{DD} = 1.3$ to 5.5 V	–3	–	+3	ppm/V
External capacitance	C_g	Applied to XIN pin	–	–	9.1	pF
Internal oscillation capacitance	C_d	Applied to XOUT pin	–	8	–	pF

*1. Reference value

■ **DC Electrical Characteristics**

Table 5 DC Characteristics (V_{DD} = 3.0 V)

(T_a = -40 to +85°C, V_{SS} = 0 V, VT-200 crystal oscillator (C_L = 6 pF, 32.768 kHz, C₀ = 9.1 pF) manufactured by Seiko Instruments Inc.)

Parameter	Symbol	Applicable Pin	Conditions	Min.	Typ.	Max.	Unit
Current consumption 1	I _{DD1}	–	Out of communication	–	0.25	0.93	μA
Current consumption 2	I _{DD2}	–	During communication ($\overline{\text{SCK}}$ = 100 kHz)	–	3.3	8	μA
Input current leakage 1	I _{IZH}	$\overline{\text{SCK}}$, SIO	V _{IN} = V _{DD}	–0.5	–	0.5	μA
Input current leakage 2	I _{IZL}	$\overline{\text{SCK}}$, SIO	V _{IN} = V _{SS}	–0.5	–	0.5	μA
Input current 1	I _{IH1}	CS	V _{IN} = V _{DD}	2	6	16	μA
Input current 2	I _{IH2}	CS	V _{IN} = 0.4 V	40	100	300	μA
Input current 3	I _{IH3}	CS	V _{IN} = 1.0 V	–	215	–	μA
Output current leakage 1	I _{OZH}	SIO, $\overline{\text{INT}}$	V _{OUT} = V _{DD}	–0.5	–	0.5	μA
Output current leakage 2	I _{OZL}	SIO, $\overline{\text{INT}}$	V _{OUT} = V _{SS}	–0.5	–	0.5	μA
Input voltage 1	V _{IH}	CS, $\overline{\text{SCK}}$, SIO	–	0.8 × V _{DD}	–	V _{SS} + 5.5	V
Input voltage 2	V _{IL}	CS, $\overline{\text{SCK}}$, SIO	–	V _{SS} – 0.3	–	0.2 × V _{DD}	V
Output current 1	I _{OL1}	$\overline{\text{INT}}$	V _{OUT} = 0.4 V	3	5	–	mA
Output current 2	I _{OL2}	SIO	V _{OUT} = 0.4 V	5	10	–	mA
Power supply voltage detection voltage	V _{DET}	–	–	0.65	1	1.35	V

Table 6 DC Characteristics (V_{DD} = 5.0 V)

(T_a = -40 to +85°C, V_{SS} = 0 V, VT-200 crystal oscillator (C_L = 6 pF, 32.768 kHz, C₀ = 9.1 pF) manufactured by Seiko Instruments Inc.)

Parameter	Symbol	Applicable Pin	Conditions	Min.	Typ.	Max.	Unit
Current consumption 1	I _{DD1}	–	Out of communication	–	0.3	1.1	μA
Current consumption 2	I _{DD2}	–	During communication ($\overline{\text{SCK}}$ = 100 kHz)	–	6	14	μA
Input current leakage 1	I _{IZH}	$\overline{\text{SCK}}$, SIO	V _{IN} = V _{DD}	–0.5	–	0.5	μA
Input current leakage 2	I _{IZL}	$\overline{\text{SCK}}$, SIO	V _{IN} = V _{SS}	–0.5	–	0.5	μA
Input current 1	I _{IH1}	CS	V _{IN} = V _{DD}	8	16	50	μA
Input current 2	I _{IH2}	CS	V _{IN} = 0.4 V	40	150	350	μA
Input current 3	I _{IH3}	CS	V _{IN} = 2.0 V	–	610	–	μA
Output current leakage 1	I _{OZH}	SIO, $\overline{\text{INT}}$	V _{OUT} = V _{DD}	–0.5	–	0.5	μA
Output current leakage 2	I _{OZL}	SIO, $\overline{\text{INT}}$	V _{OUT} = V _{SS}	–0.5	–	0.5	μA
Input voltage 1	V _{IH}	CS, $\overline{\text{SCK}}$, SIO	–	0.8 × V _{DD}	–	V _{SS} + 5.5	V
Input voltage 2	V _{IL}	CS, $\overline{\text{SCK}}$, SIO	–	V _{SS} – 0.3	–	0.2 × V _{DD}	V
Output current 1	I _{OL1}	$\overline{\text{INT}}$	V _{OUT} = 0.4 V	5	8	–	mA
Output current 2	I _{OL2}	SIO	V _{OUT} = 0.4 V	6	13	–	mA
Power supply voltage detection voltage	V _{DET}	–	–	0.65	1	1.35	V

■ AC Electrical Characteristics

Table 7 Measurement Conditions

Input pulse voltage	$V_{IH} = 0.8 \times V_{DD}$, $V_{IL} = 0.2 \times V_{DD}$
Input pulse rise/fall time	20 ns
Output determination voltage	$V_{OH} = 0.8 \times V_{DD}$, $V_{OL} = 0.2 \times V_{DD}$
Output load	80 pF + pull-up resistor 10 k Ω

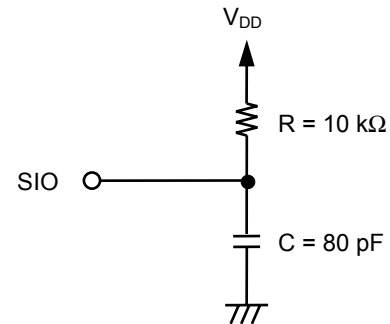

Remark The power supplies of the IC and load have the same electrical potential.

Figure 9 Output Load Circuit

Table 8 AC Electrical Characteristics

($T_a = -40$ to $+85^\circ\text{C}$)

Parameter	Symbol	$V_{DD}^{*2} \geq 1.3 \text{ V}$			$V_{DD}^{*2} \geq 3.0 \text{ V}$			Unit
		Min.	Typ.	Max.	Min.	Typ.	Max.	
Clock pulse width	t_{SCK}	5	–	250000	1	–	250000	μs
Setup time before CS rise	t_{DS}	1	–	–	0.2	–	–	μs
Hold time after CS rise	t_{CSH}	1	–	–	0.2	–	–	μs
Input data setup time	t_{ISU}	1	–	–	0.2	–	–	μs
Input data hold time	t_{IHO}	1	–	–	0.2	–	–	μs
Output data definition time ^{*1}	t_{ACC}	–	–	3.5	–	–	1	μs
Setup time before CS fall	t_{CSS}	1	–	–	0.2	–	–	μs
Hold time after CS fall	t_{DH}	1	–	–	0.2	–	–	μs
Input rise/fall time	t_R, t_F	–	–	0.1	–	–	0.05	μs

*1. Since the output format of the SIO pin is Nch open-drain output, output data definition time is determined by the values of the load resistance (R_L) and load capacity (C_L) outside the IC. Therefore, use this value only as a reference value.

*2. Regarding the power supply voltage, refer to “■ Recommended Operation Conditions”.

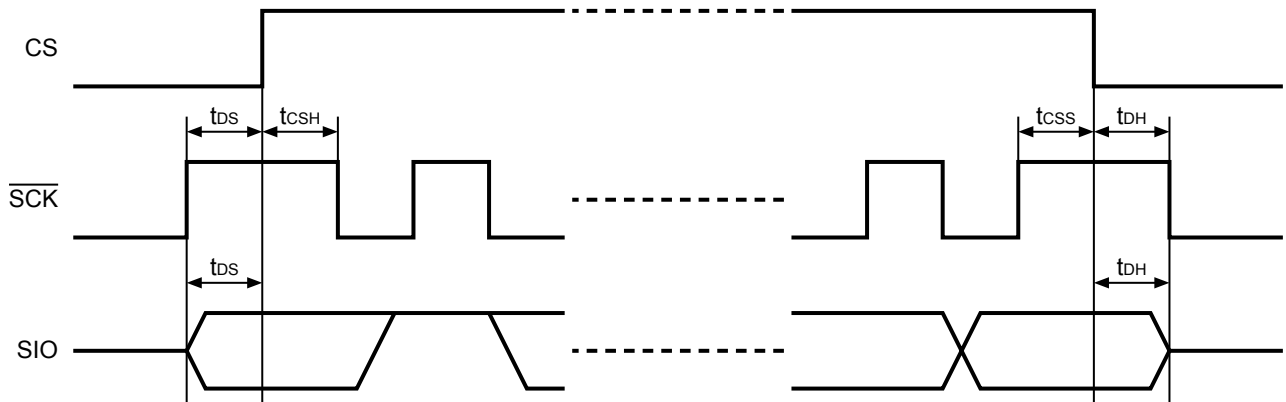

Figure 10 Timing Diagram 1 during 3-wire Communication

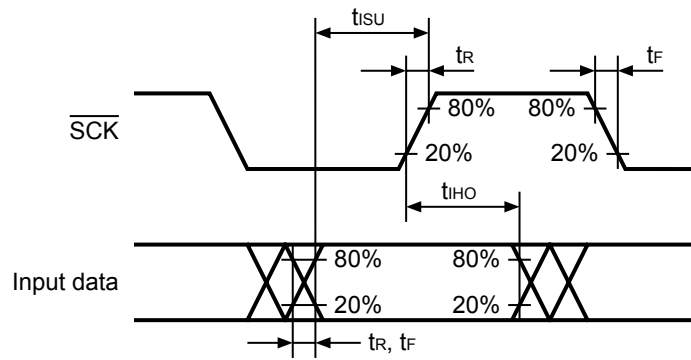

Figure 11 Timing Diagram 2 during 3-wire Communication

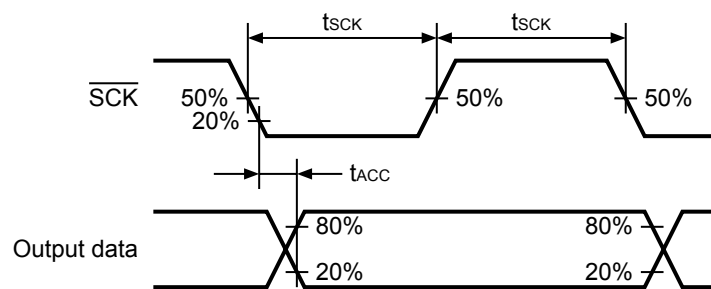

Figure 12 Timing Diagram 3 during 3-wire Communication

■ Configuration of Data Communication

1. Configuration of data communication

After setting the CS pin "H", transmit the 4-bit fixed code "0110", after that, transmit a 3-bit command and 1-bit Read/Write command. Next, data is output or input from B7. Regarding details, refer to "■ Serial Interface".

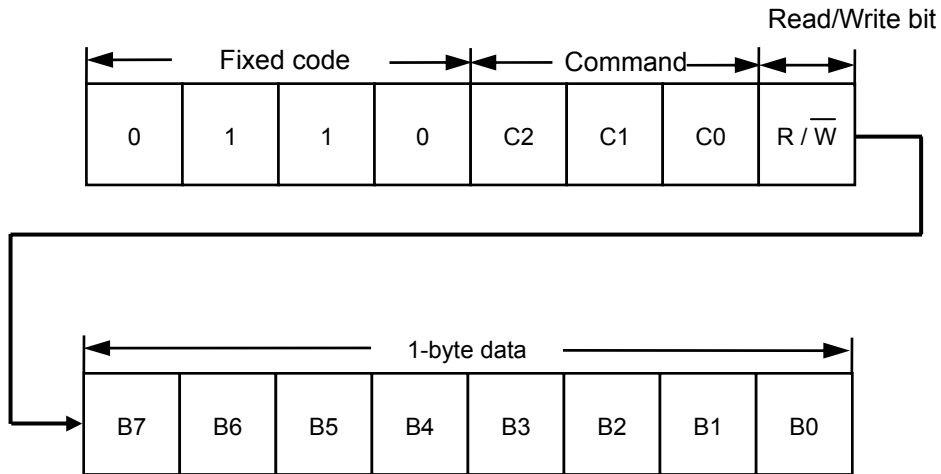

Figure 13 Data Communication

2. Configuration of command

8 types of command are available for the S-35190A, The S-35190A does Read/Write the various registers by inputting these fixed codes and commands. The S-35190A does not perform any operation with any codes and commands other than those below.

Table 9 List of Command

Fixed Code	Command			Data									
	C2	C1	C0	Description	B7	B6	B5	B4	B3	B2	B1	B0	
0110	0	0	0	Status register 1 access	RESET* ¹	$\overline{12/24}$	SC0* ²	SC1* ²	INT1* ³	INT2* ³	BLD* ⁴	POC* ⁴	
	0	0	1	Status register 2 access	INT1FE	INT1ME	INT1AE	32kE	SC2* ²	SC3* ²	INT2AE	TEST* ⁵	
	0	1	0	Real-time data 1 access (year data to)	Y1	Y2	Y4	Y8	Y10	Y20	Y40	Y80	
					M1	M2	M4	M8	M10	$\overline{*6}$	$\overline{*6}$	$\overline{*6}$	$\overline{*6}$
					D1	D2	D4	D8	D10	D20	$\overline{*6}$	$\overline{*6}$	$\overline{*6}$
					W1	W2	W4	$\overline{*6}$	$\overline{*6}$	$\overline{*6}$	$\overline{*6}$	$\overline{*6}$	$\overline{*6}$
					H1	H2	H4	H8	H10	H20	AM/PM	$\overline{*6}$	$\overline{*6}$
					m1	m2	m4	m8	m10	m20	m40	$\overline{*6}$	$\overline{*6}$
	s1	s2	s4	s8	s10	s20	s40	$\overline{*6}$	$\overline{*6}$				
	0	1	1	Real-time data 2 access (hour data to)	H1	H2	H4	H8	H10	H20	AM/PM	$\overline{*6}$	
m1					m2	m4	m8	m10	m20	m40	$\overline{*6}$		
s1					s2	s4	s8	s10	s20	s40	$\overline{*6}$		
1	0	0	INT register 1 access (alarm time 1: week/hour/minute) (INT1AE = 1, INT1ME = 0, INT1FE = 0)	W1	W2	W4	$\overline{*6}$	$\overline{*6}$	$\overline{*6}$	$\overline{*6}$	A1WE		
			H1	H2	H4	H8	H10	H20	AM/PM	A1HE			
				m1	m2	m4	m8	m10	m20	m40	A1mE		
				INT register 1 access (output of user-set frequency) (INT1ME = 0, INT1FE = 1)	1 Hz	2 Hz	4 Hz	8 Hz	16 Hz	SC4* ²	SC5* ²	SC6* ²	
1	0	1	INT register 2 access (alarm time 2: week/hour/minute) (INT2AE = 1)	W1	W2	W4	$\overline{*6}$	$\overline{*6}$	$\overline{*6}$	$\overline{*6}$	A2WE		
			H1	H2	H4	H8	H10	H20	AM/PM	A2HE			
				m1	m2	m4	m8	m10	m20	m40	A2mE		
1	1	0	Clock-correction register access	V0	V1	V2	V3	V4	V5	V6	V7		
1	1	1	Free register access	F0	F1	F2	F3	F4	F5	F6	F7		

- *1. Write-only flag. The S-35190A initializes by writing “1” in this register.
- *2. Scratch bit. A R/W-enabled, user-free register.
- *3. Read-only flag. Valid only when using the alarm function. When the alarm time matches, this flag is set to “1”, and it is cleared to “0” when Read.
- *4. Read-only flag. “POC” is set to “1” when power is applied. It is cleared to “0” when Read. Regarding “BLD”, refer to “**Low Power Supply Voltage Detection Circuit**”.
- *5. Test bit for SII. Be sure to set “0” in use.
- *6. No effect by Write. It is “0” when Read.

■ Configuration of Register

1. Real-time data register

The real-time data register is a 7-byte register that stores the data of year, month, day, day of the week, hour, minute, and second in the BCD code. To Write/Read real-time data 1 access, transmit/receive the data of year in B7, month, day, day of the week, hour, minute, second in B0, in 7-byte. When you skip the procedure to access the data of year, month, day, day of the week, Read/Write real-time data 2 access. In this case, transmit/receive the data of hour in B7, minute, second in B0, in 3-byte.

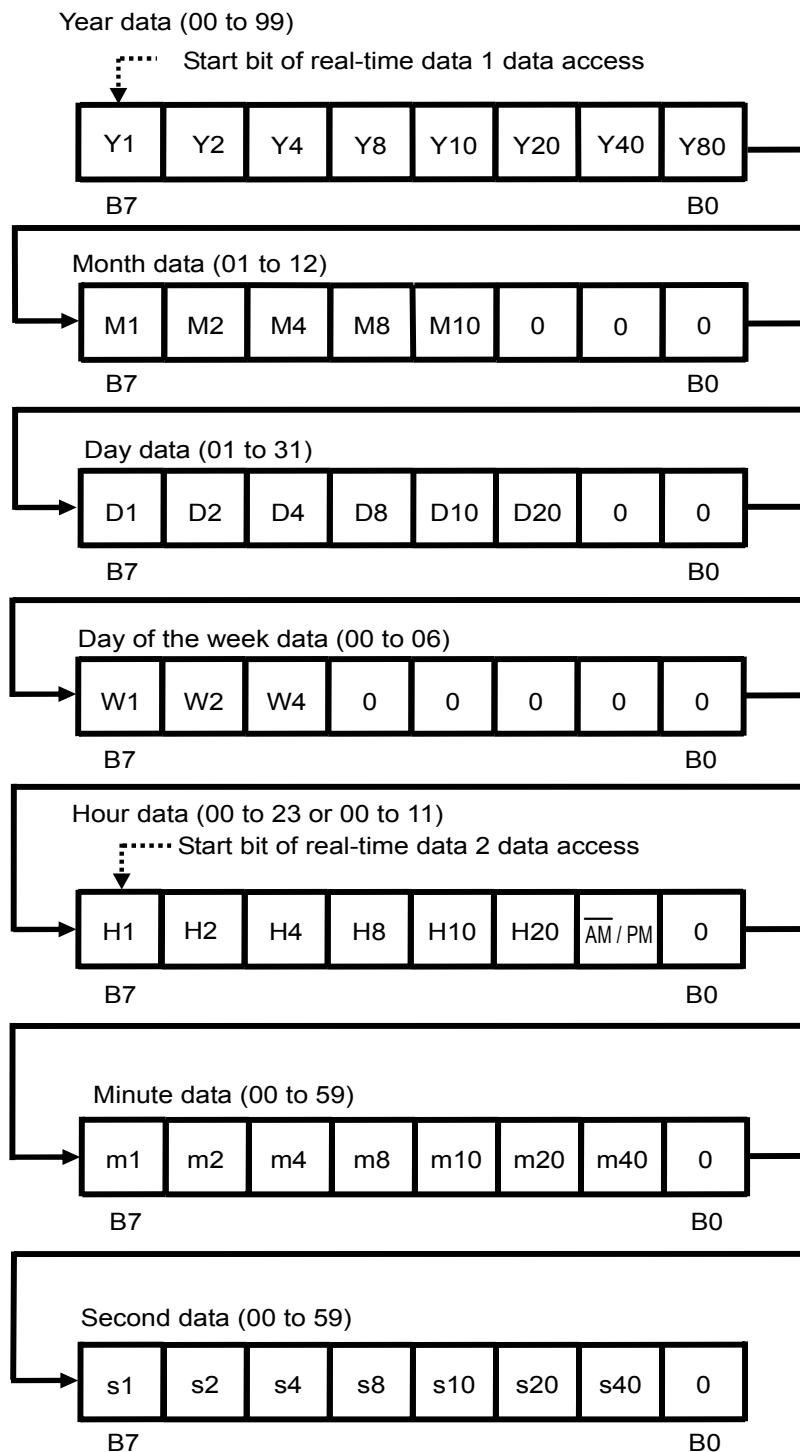

Figure 14 Real-time Data Register

Year data (00 to 99): Y1, Y2, Y4, Y8, Y10, Y20, Y40, Y80

Sets the lower two digits of the Western calendar year (00 to 99) and links together with the auto calendar function until 2099.

Example: 2053 (Y1, Y2, Y4, Y8, Y10, Y20, Y40, Y80) = (1, 1, 0, 0, 1, 0, 1, 0)

Month data (01 to 12): M1, M2, M4, M8, M10

Example: December (M1, M2, M4, M8, M10, 0, 0, 0) = (0, 1, 0, 0, 1, 0, 0, 0)

Day data (01 to 31): D1, D2, D4, D8, D10, D20

The count value is automatically changed by the auto calendar function.

1 to 31: Jan., Mar., May, July, Aug., Oct., Dec., 1 to 30: April, June, Sep., Nov.

1 to 29: Feb. (leap year), 1 to 28: Feb. (non-leap year)

Example: 29 (D1, D2, D4, D8, D10, D20, 0, 0) = (1, 0, 0, 1, 0, 1, 0, 0)

Day of the week data (00 to 06): W1, W2, W4

A septenary up counter. Day of the week is counted in the order of 00, 01, 02, ..., 06, and 00. Set up day of the week and the count value.

Hour data (00 to 23 or 00 to 11): H1, H2, H4, H8, H10, H20, $\overline{\text{AM}} / \text{PM}$

In a 12-hour expression, write 0; AM, 1; PM in the $\overline{\text{AM}} / \text{PM}$ bit. In a 24-hour expression, users can Write either 0 or 1. 0 is read when the hour data is from 00 to 11, and 1 is read when from 12 to 23.

Example (12-hour expression): 12 p.m. (H1, H2, H4, H8, H10, H20, $\overline{\text{AM}} / \text{PM}$, 0) = (0, 1, 0, 0, 1, 0, 1, 0)

Example (24-hour expression): 22 (H1, H2, H4, H8, H10, H20, $\overline{\text{AM}} / \text{PM}$, 0) = (0, 1, 0, 0, 0, 1, 1, 0)

Minute data (00 to 59): m1, m2, m4, m8, m10, m20, m40

Example: 32 minutes (m1, m2, m4, m8, m10, m20, m40, 0) = (0, 1, 0, 0, 1, 1, 0, 0)

Example: 55 minutes (m1, m2, m4, m8, m10, m20, m40, 0) = (1, 0, 1, 0, 1, 0, 1, 0)

Second data (00 to 59): s1, s2, s4, s8, s10, s20, s40

Example: 19 seconds (s1, s2, s4, s8, s10, s20, s40, 0) = (1, 0, 0, 1, 1, 0, 0, 0)

2. Status register 1

Status register 1 is a 1-byte register that is used to display and set various modes. The bit configuration is shown below.

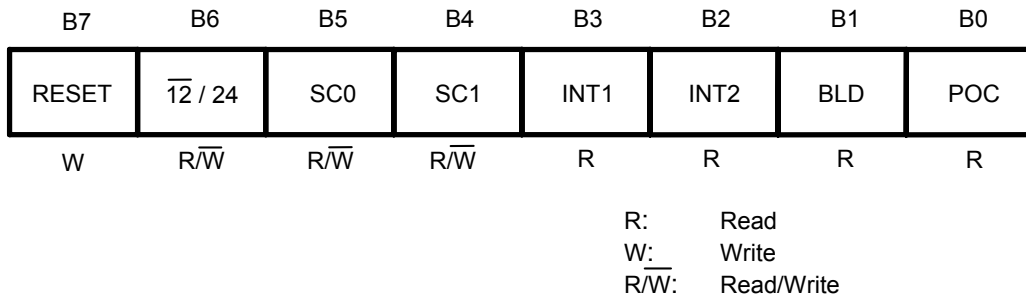

Figure 15 Status Register 1

B0 : POC

This flag is used to confirm whether the power is on. The power-on detector operates at power-on and B0 is set to "1". This flag is Read-only. Once it is read, it is automatically set to "0". When this flag is "1", be sure to initialize. Regarding the operation after power-on, refer to "■ Power-on Detection Circuit and Register Status".

B1 : BLD

This flag is set to "1" when the power supply voltage decreases to the level of detection voltage (V_{DET}) or less. Users can detect a drop in the power supply voltage. This flag is set to "1" once, is not set to "0" again even if the power supply increases to the level of detection voltage (V_{DET}) or more. This flag is Read-only. When this flag is "1", be sure to initialize. Regarding the operation of the power supply voltage detection circuit, refer to "■ Low Power Supply Detection Circuit".

B2 : INT2, B3 : INT1

This flag indicates the time set by alarm and when the time has reached it. This flag is set to "1" when the time that users set by using the alarm interrupt function has come. The INT1 flag in "1" at alarm 1 interrupt mode, the INT2 flag in "1" at alarm 2 interrupt mode. This flag is Read-only. This flag is read once, is set to "0" automatically.

B4 : SC1, B5 : SC0

These flags are SRAM type registers, they are 2 bits as a whole, can be freely set by users.

B6 : $\overline{12/24}$

This flag is used to set 12-hour or 24-hour expression.

- 0 : 12-hour expression
- 1 : 24-hour expression

B7 : RESET

The internal IC is initialized by setting this bit to "1". This bit is Write-only. It is always "0" when Read. When applying the power supply voltage to the IC, be sure to write "1" to this bit to initialize the circuit. Regarding each status of data after initialization, refer to "■ Register Status After Initialization".

3. Status register 2

Status register 2 is a 1-byte register that is used to display and set various modes. The bit configuration is shown below.

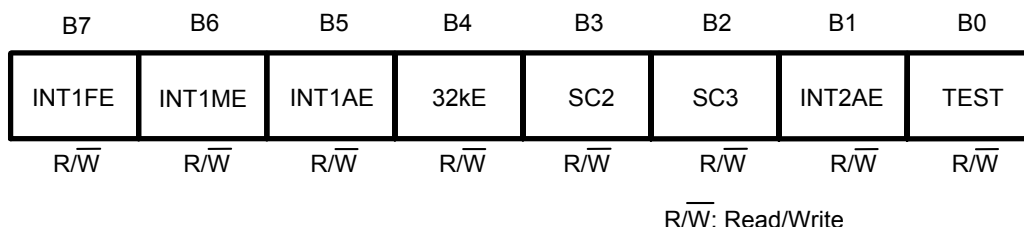

Figure 16 Status Register 2

B0 : TEST

This is a test flag for SII. Be sure to set this flag to “0” in use. If this flag is set to “1”, be sure to initialize to set “0”.

B1 : INT2AE

This is an enable bit for alarm 2 interrupt. When this bit is “0”, alarm 2 interrupt is disabled. When it is “1”, it is enabled. To use alarm 2 interrupt, access the INT register 2 after enabling this flag.

Caution Note that alarm 2 interrupt is output from the \overline{INT} pin regardless of the settings in flags B4 to B7.

B2 : SC3, B3 : SC2

These are 2-bit SRAM type registers that can be freely set by users.

B4 : 32kE, B5 : INT1AE, B6 : INT1ME, B7 : INT1FE

These bits are used to select the output mode for the \overline{INT} pin. **Table 10** shows how to select the mode. To use alarm 1 interrupt, access the INT register 1 after setting the alarm 1 interrupt mode.

Table 10 Output Modes for \overline{INT} Pin

32kE	INT1AE	INT1ME	INT1FE	\overline{INT} Pin Output Mode
0	0	0	0	No interrupt
0	-*1	0	1	Output of user-set frequency
0	-*1	1	0	Per-minute edge interrupt
0	0	1	1	Minute-periodical interrupt 1 (50% duty)
0	1	0	0	Alarm 1 interrupt
0	1	1	1	Minute-periodical interrupt 2
1	-*1	-*1	-*1	32.768 kHz output

*1. Don't care (Both of 0 and 1 are acceptable).

4. INT register 1 and INT register 2

The INT register 1 is to set up the output of user-set frequency, or to set up alarm 1 interrupt. The INT register 2 is for setting alarm 2 interrupt. Users are able to switch the output mode by using the status register 2. If selecting to use the output mode for alarm interrupt by status register 2; this register works as the alarm-time data register. In the INT register 1, if selecting the output of user-set frequency by status register 2; this register works as the data register to set the frequency for clock output. From the $\overline{\text{INT}}$ pin, a clock pulse and alarm interrupt are output, according to the or-condition that these two registers have.

(1) Alarm interrupt

Users can set the alarm time (the data of day of the week, hour, minute) by using the INT register 1 and 2 which are 3-byte data registers. The configuration of register is as well as the data register of day of the week, hour, minute, in the real-time data register; is expressed by the BCD code. Do not set a nonexistent day. Users are necessary to set up the alarm-time data according to the 12/24 hour expression that they set by using the status register 1.

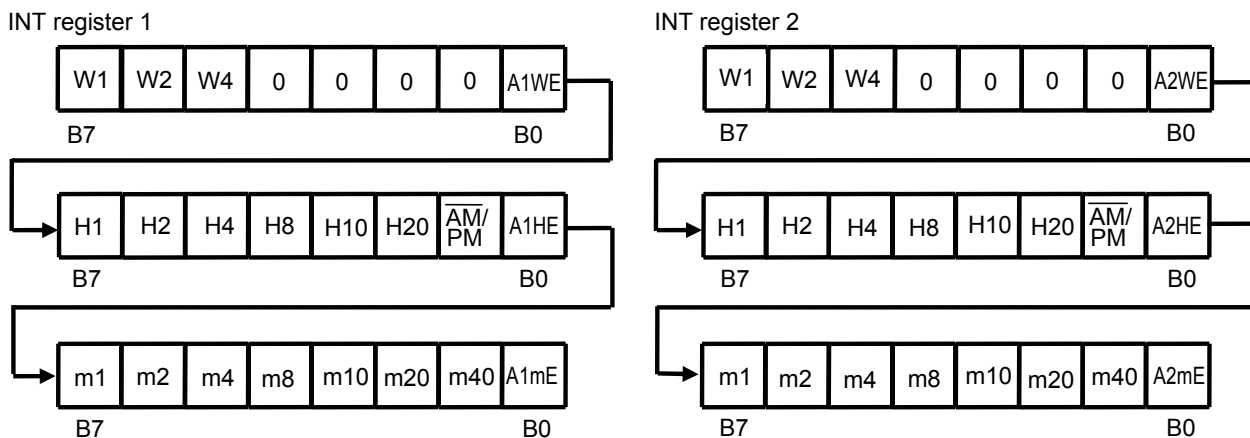

Figure 17 INT Register 1 and INT Register 2 (Alarm-Time Data)

The INT register 1 has A1WE, A1HE, A1mE at B0 in each byte. It is possible to make data valid; the data of day of the week, hour, minute which are in the corresponded byte; by setting these bits to “1”. This is as well in A2WE, A2HE, A2mE in the INT register 2.

Setting example: alarm time “7:00 pm” in the INT register 1

(a) 12-hour expression (status register 1 B6 = 0)

set up 7:00 PM

Data written to INT register 1

Day of the week	_*1	_*1	_*1	_*1	_*1	_*1	_*1	0	
Hour	1	1	1	0	0	0	1	1	
Minute	0	0	0	0	0	0	0	1	
	B7							B0	

*1. Don't care (Both of 0 and 1 are acceptable).

(b) 24-hour expression (status register 1 B6 = 1)

set up 19:00 PM

Data written to INT register 1

Day of the week	_*1	_*1	_*1	_*1	_*1	_*1	_*1	0	
Hour	1	0	0	1	1	0	1*2	1	
Minute	0	0	0	0	0	0	0	1	
	B7							B0	

*1. Don't care (Both of 0 and 1 are acceptable).

*2. Set up $\overline{\text{AM}}/\text{PM}$ flag along with the time setting.

(2) Output of user-set frequency

The INT register 1 is a 1-byte data register to set up the output frequency. Setting each bit B7 to B3 in the register to “1”, the frequency which corresponds to the bit is output in the AND-form. SC4 to SC6 is 3-bit SRAM type registers that can be freely set by users.

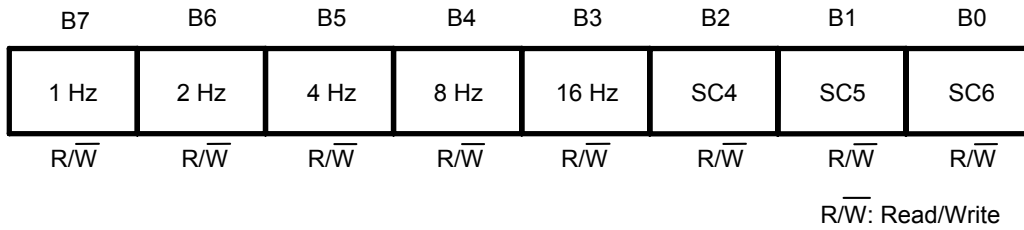

Figure 18 INT Register 1 (Data Register for Output Frequency)

Example: B7 to B3 = 50h

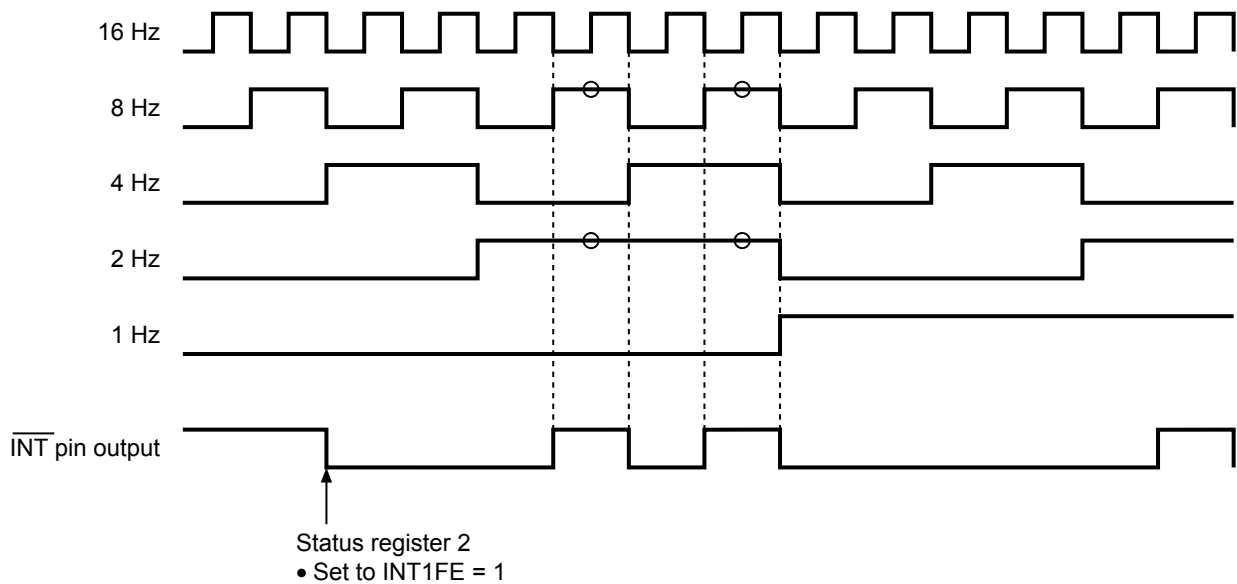

Figure 19 Example of Output from INT Register 1 (Data Register for Output Frequency)

5. Clock-correction register

The clock-correction register is a 1-byte register that is used to correct advance/delay of the clock. When not using this function, set this register to "00h". Regarding the register values, refer to "■ Function to Clock-Correction".

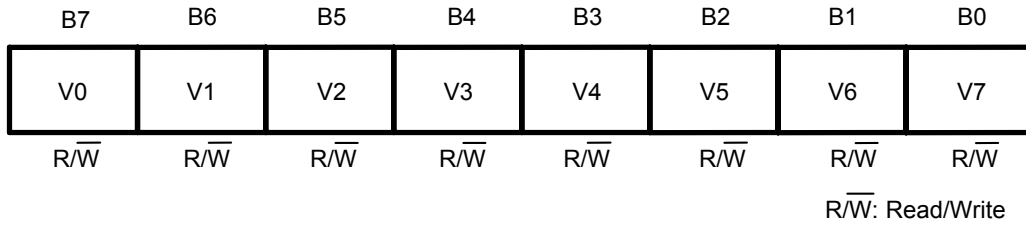

Figure 20 Clock-Correction Register

6. Free register

The free register is a 1-byte SRAM type register that can be set freely by users.

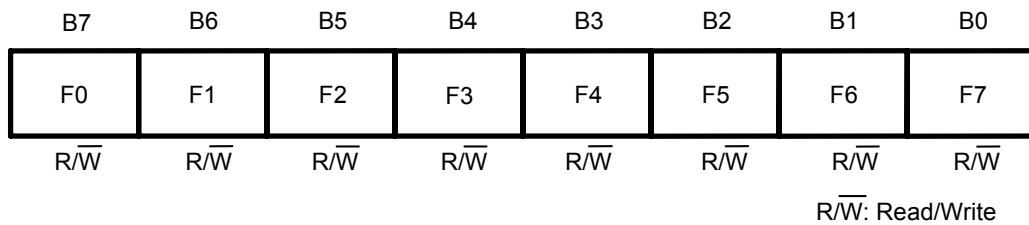

Figure 21 Free Register

■ **Power-on Detector and Register Status**

The power-on detection circuit operates by power-on the S-35190A, as a result each register is cleared; each register is set as follows.

Real-time data register :	00 (Y), 01 (M), 01 (D), 0 (day of the week), 00 (H), 00 (M), 00 (S)
Status register 1 :	"01h"
Status register 2 :	"01h"
INT register 1 :	"80h"
INT register 2 :	"00h"
Clock correction register :	"00h"
Free register :	"00h"

"1" is set in the POC flag (B0 in the status register 1) to indicate that power has been applied. To correct the oscillation frequency, the status register 2 goes in the mode the output of user-set frequency, so that 1 Hz clock pulse is output from the $\overline{\text{INT}}$ pin. When "1" is set in the POC flag, be sure to initialize. The POC flag is set to "0" due to initialization so that the output of user-set frequency mode is cleared. (Refer to "■ Register Status After Initialization".)

For the regular operation of power-on detection circuit, as seen in **Figure 22**, the period to power-up the S-35190A is that the voltage reaches 1.3 V within 10 ms after setting the IC's power supply voltage at 0 V. When the power-on detection circuit is not working normally is; the POC flag (B0 in the status register) is not in "1", or 1 Hz is not output from the INT pin. In this case, power-on the S-35190A once again because the internal data may be in the indefinite status.

Do not transmit data immediately after power-on at least 0.5 sec because the power-on detection circuit is operating.

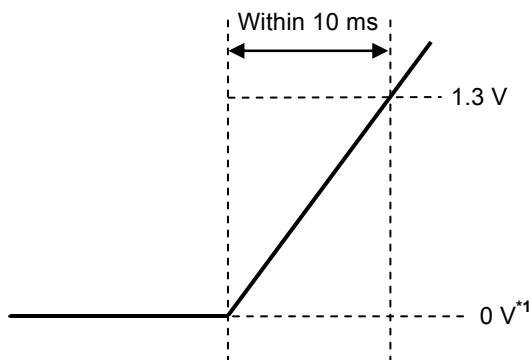

*1. 0 V indicates that there are no potential differences between the VDD pin and VSS pin of the S-35190A.

Figure 22 How to Raise the Power Supply Voltage

■ Register Status After Initialization

The status of each register after initialization is as follows.

- Real-time data register : 00 (Y), 01 (M), 01 (D), 0 (day of the week), 00 (H), 00 (M), 00 (S)
- Status register 1 : "0 B6 B5 B4 0 0 0 0 b"
(In B6, B5, B4, the data of B6, B5, B6 in the status register 1 at initialization is set. Refer to **Figure 23**.)
- Status register 2 : "00h"
- INT register 1 : "00h"
- INT register 2 : "00h"
- Clock correction register : "00h"
- Free register : "00h"

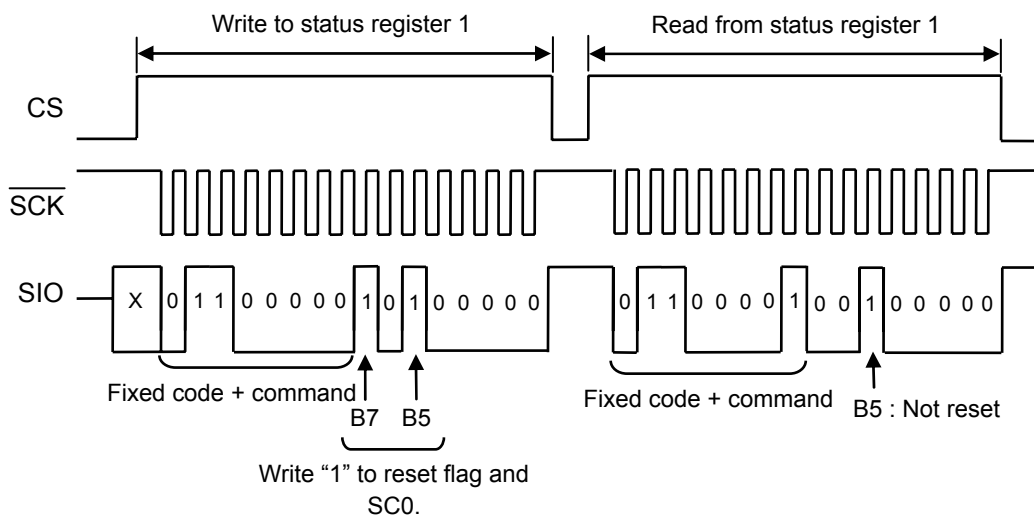

Figure 23 Status Register 1 Data at Initialization

■ Low Power Supply Voltage Detection Circuit

The S-35190A has a low power supply voltage detection circuit, so that users can monitor drops in the power supply voltage by reading the BLD flag (B1 in the status register 1). There is a hysteresis width of approx. 0.15 V (Typ.) between detection voltage and release voltage (refer to “■ Characteristics (Typical Data)”). The low power supply voltage detection circuit does the sampling operation only once in one sec for 15.6 ms.

If the power supply voltage decreases to the level of detection voltage (V_{DET}) or less, “1” is set to the BLD flag so that sampling operation stops. Once “1” is detected in the BLD flag, no sampling operation is performed even if the power supply voltage increases to the level of release voltage or more, and “1” is held in the BLD flag. After initialization, or once the BLD flag is read, the BLD flag is automatically set to “0” to restart the sampling operation.

If the BLD flag is “1” even after the power supply voltage is recovered, the internal circuit may be in the indefinite status. In this case, be sure to initialize the circuit.

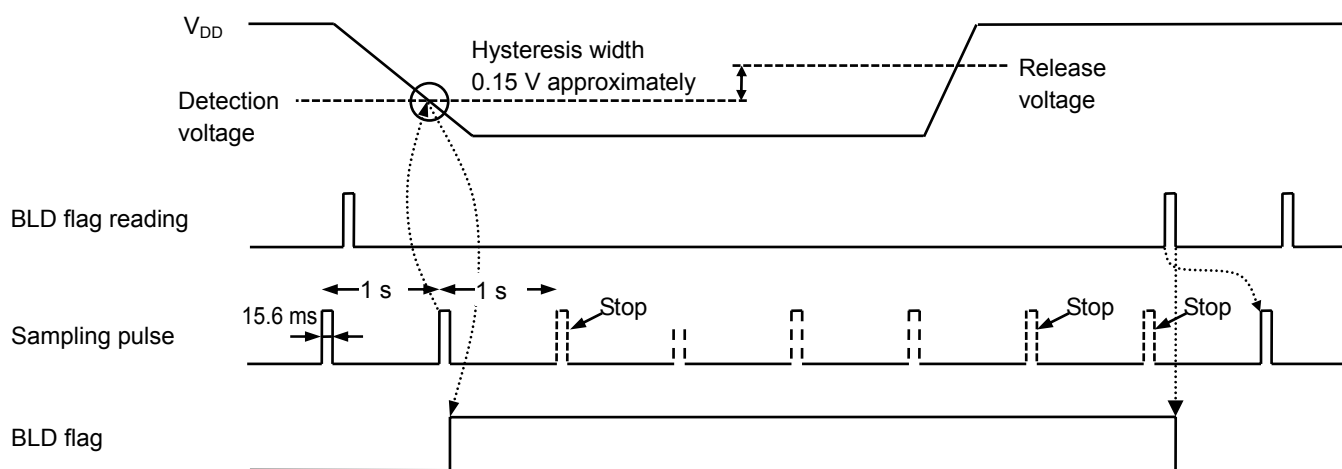

Figure 24 Timing of Low Power Supply Voltage Detection Circuit

■ Circuits Power-on and Low Power Supply Voltage Detection

Figure 25 shows the changes of the POC flag and BLD flag due to V_{DD} fluctuation.

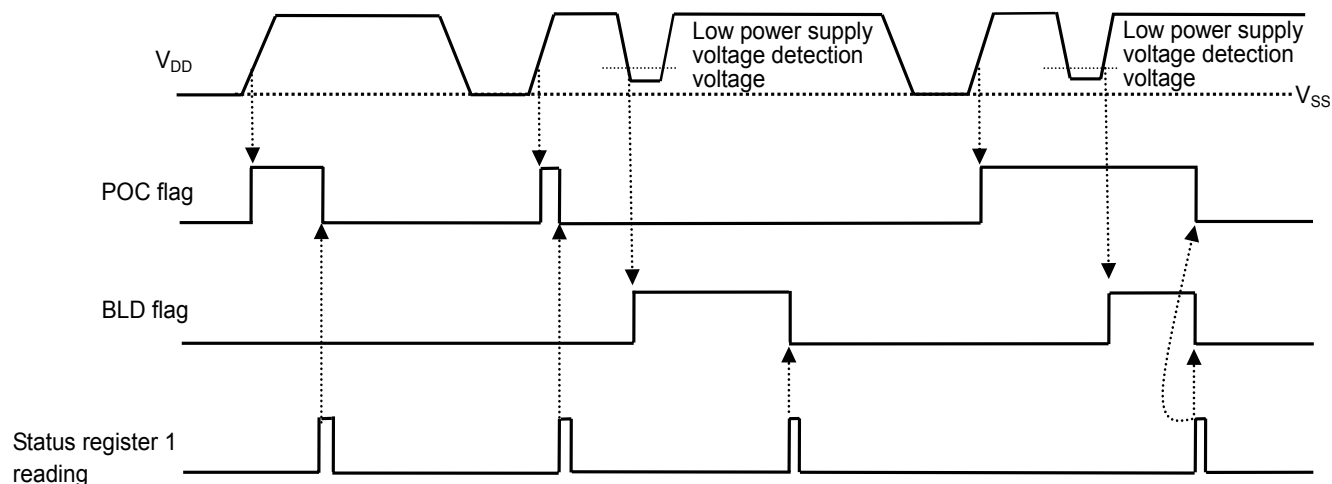

Figure 25 POC Flag and BLD Flag

■ Correction of Nonexistent Data and End-of-Month

When users write the real-time data, the S-35190A checks it. In case that the data is invalid, the S-35190A does the following procedures.

1. Processing of nonexistent data

Table 11 Processing of Nonexistent Data

Register	Normal Data	Nonexistent Data	Result	
Year data	00 to 99	XA to XF, AX to FX	00	
Month data	01 to 12	00, 13 to 19, XA to XF	01	
Day data	01 to 31	00, 32 to 39, XA to XF	01	
Day of the week data	0 to 6	7	0	
Hour data *1	24-hour	0 to 23	24 to 29, 3X, XA to XF	00
	12-hour	0 to 11	12 to 19, 2X, 3X, XA to XF	00
Minute data	00 to 59	60 to 79, XA to XF	00	
Second data *2	00 to 59	60 to 79, XA to XF	00	

*1. In a 12-hour expression, Write the AM/PM flag (B1 in hour data in the real-time data register).

In 24-hour expression, the AM/PM flag in the real-time data register is omitted. However in the flag in Read, users are able to read 0; 0 to 11, 1; 12 to 23.

*2. Processing of nonexistent data, regarding second data, is done by a carry pulse which is generated one sec after, after Write. At this point the carry pulse is sent to the minute-counter.

2. Correction of end-of-month

A nonexistent day, such as February 30 and April 31, is set to the first day of the next month.

■ $\overline{\text{INT}}$ Pin Output Mode

These are selectable for the $\overline{\text{INT}}$ pin output mode;

Alarm 1 interrupt, alarm 2 interrupt, the output of user-set frequency, per-minute edge interrupt output, minute-periodical interrupt output 1 and 2, 32.768 kHz output.

In alarm 1 interrupt/output of frequency; set data in the INT register 1. In alarm 2 interrupt, set data in the INT register 2. To switch the output mode, use the status register 2. Refer to “3. Status register 2” in “■ Configuration of Register”.

When switching the output mode, be careful of the output status of the pin. Especially, when using alarm interrupt/output of frequency, switch the output mode after setting “00h” in the INT register 1 or 2. Alarm 2 interrupt is dependent from other modes. Regardless of other settings of mode if alarm 2 interrupt was generated, be careful that “L” is output from the $\overline{\text{INT}}$ pin. In 32.768 kHz output/per-minute edge interrupt output/minute-periodical interrupt output, it is unnecessary to set data in the INT register 1 or 2 for users.

Refer to the followings regarding each operation of output modes.

1. Alarm interrupt output

Alarm interrupt output is the function to output “L” from the $\overline{\text{INT}}$ pin, at the alarm time which is set by user has come. If setting the pin output to “H”, turn off the alarm function by setting “0” in INT1AE/INT2AE in the status register 2.

To set the alarm time, set the data of day of the week, hour, minute in the INT register 1 or 2, set the data of year, month, day in the INT register 1 or 2. Refer to “4. INT register 1 and INT register 2” in “■ Configuration of Register”.

Alarm setting of W (day of the week), H (hour), m (minute)”

- | | |
|--|--|
| Status register 2 setting
• Alarm 1 interrupt
32kE = 0, INT1ME = INT1FE = 0
• Alarm 2 interrupt
None | INT register x alarm enable flag
• AxHE = AxmE = AxWE = “1” |
|--|--|

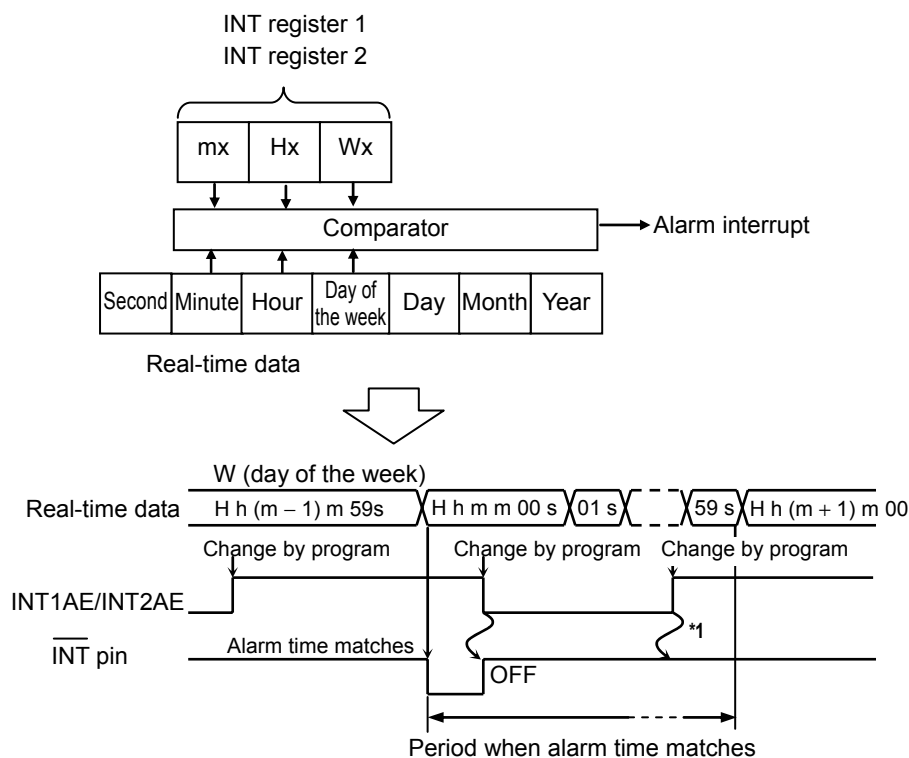

*1. If users clear INT1AE/INT2AE once; “L” is not output from the $\overline{\text{INT}}$ pin by setting INT1AE/INT2AE enable again, within a period when the alarm time matches real-time data.

Figure 26 Alarm Interrupt Output Timing (1/2)

Alarm setting of "H (hour)"

Status register 2 setting

- Alarm 1 interrupt
32kE = 0, INT1ME = INT1FE = 0
- Alarm 2 interrupt
None

INT register x alarm enable flag

- AxWE = AxmE = "0", AxHE = "1"

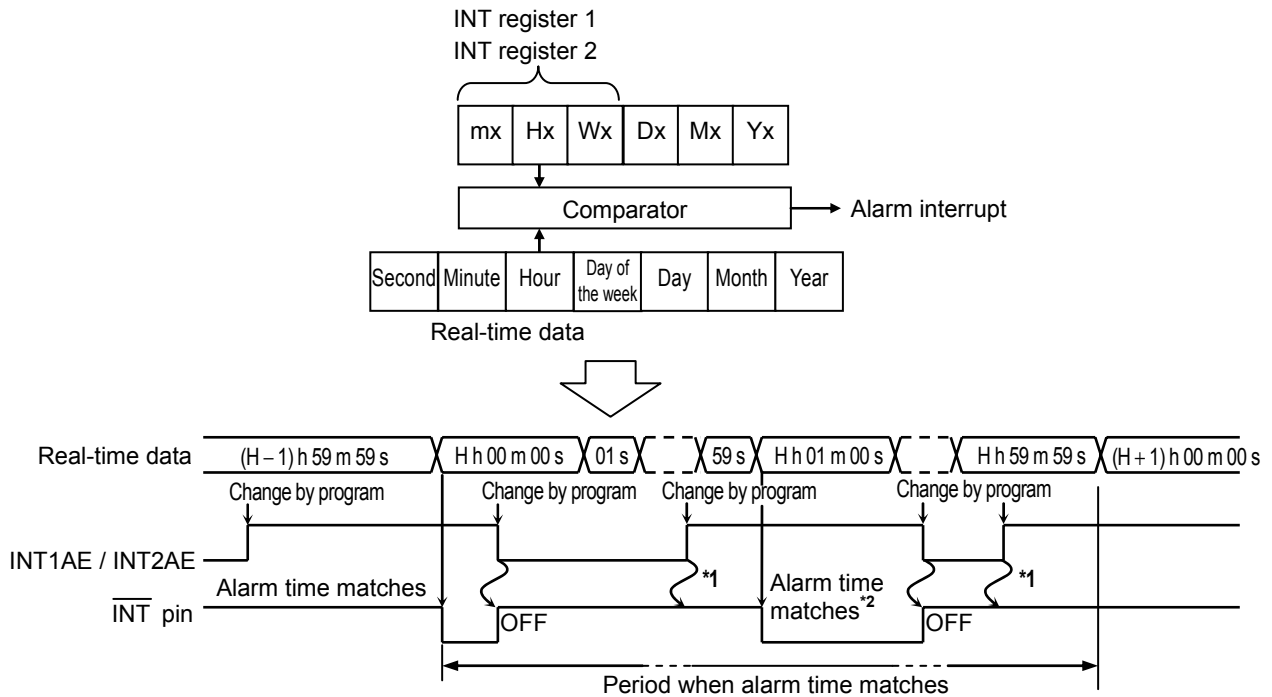

*1. If users clear INT1AE/INT2AE once; "L" is not output from the $\overline{\text{INT}}$ pin by setting INT1AE/INT2AE enable again, within a period when the alarm time matches real-time data.

*2. If turning the alarm output on by changing the program, within the period when the alarm time matches real-time data, "L" is output again from the $\overline{\text{INT}}$ pin when the minute is counted up.

Figure 27 Alarm Interrupt Output Timing (2/2)

2. Output of user-set frequency

The output of user-set frequency is the function to output the frequency which is selected by using data, from the INT pin, in the AND-form. Set up the data of frequency in the INT register 1.

Refer to "4. INT register 1 and INT register 2" in "■ Configuration of Register".

Status register 2 setting

32kE = 0, INT1AE = Don't care (0 or 1), INT1ME = 0

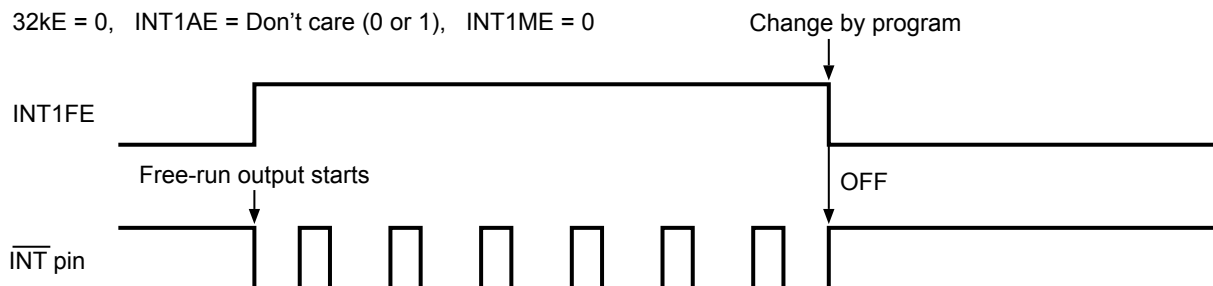

Figure 28 Output Timing of User-set Frequency

3. Per-minute edge interrupt output

Per-minute edge interrupt output is the function to output "L" from the $\overline{\text{INT}}$ pin, when the first minute-carry processing is done, after selecting the output mode. To set the pin output to "H", set "0" in INT1ME in the status register 2 to turn off the output mode of per-minute edge interrupt.

Status register 2 setting

- 32kE = 0, INT1AE = Don't care (0 or 1), INT1FE = 0

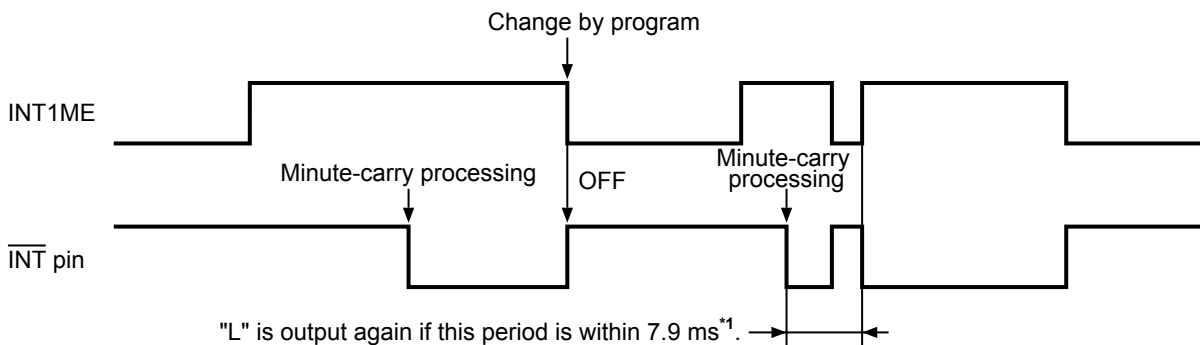

*1. Pin output is set to "H" by disabling the output mode within 7.9 ms, because the signal of this procedure is maintained for 7.9 ms. Note that pin output is set to "L" by setting enable the output mode again.

Figure 29 Timing of Per-Minute Edge Interrupt Output

4. Minute-periodical interrupt output 1

The minute-periodical interrupt 1 is the function to output the one-minute clock pulse (Duty 50%) from the $\overline{\text{INT}}$ pin, when the first minute-carry processing is done, after selecting the output mode.

Status register 2 setting

- 32kE = 0, INT1AE = 0

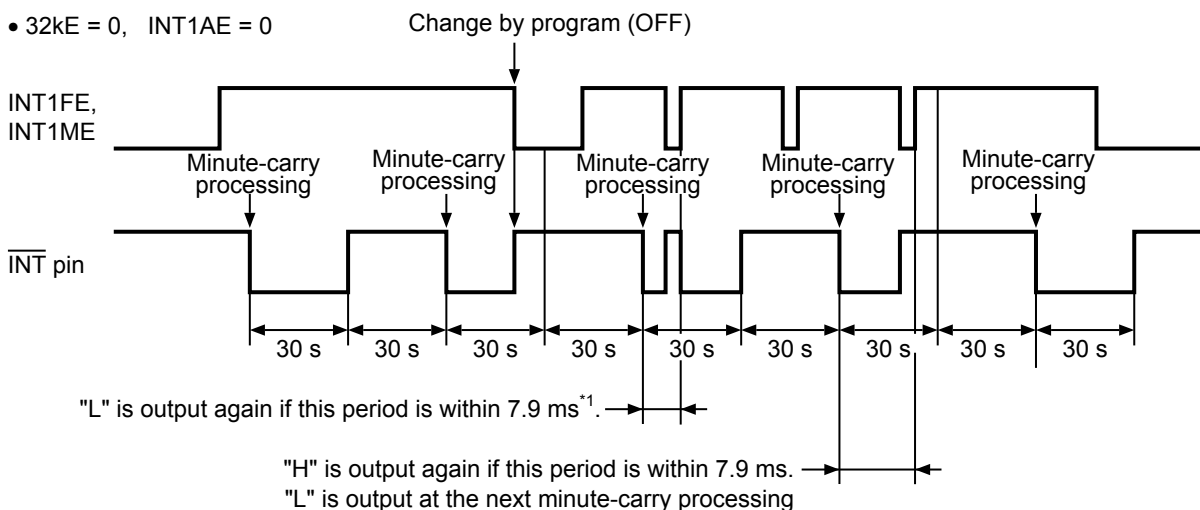

*1. Setting the output mode disable makes the pin output "H", while the output from the $\overline{\text{INT}}$ pin is in "L". Note that pin output is set to "L" by setting enable the output mode again.

Figure 30 Timing of Minute-periodical Interrupt Output 1

5. Minute-periodical interrupt output 2

The output of minute-periodical interrupt 2 is the function to output "L", for 7.9 ms, from the $\overline{\text{INT}}$ pin, synchronizing with the first minute-carry processing after selecting the output mode. However, in Read in the real-time data register, the procedure delays at max. 0.5 sec thus output "L" from the $\overline{\text{INT}}$ pin also delays at max. 0.5 sec. In Write in the real-time data register, some delay is made in the output period due to Write timing and the second-data during Write.

(a) During normal operation

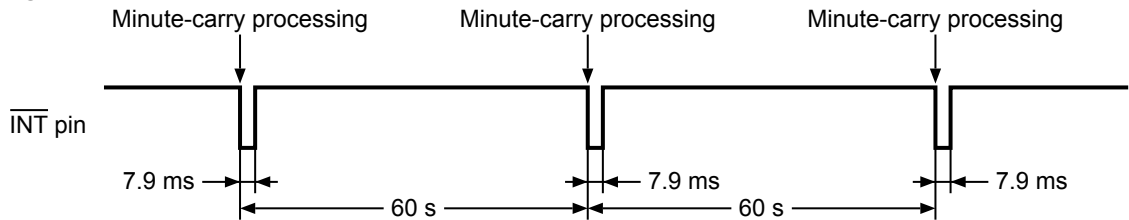

(b) During Read in the real-time data register

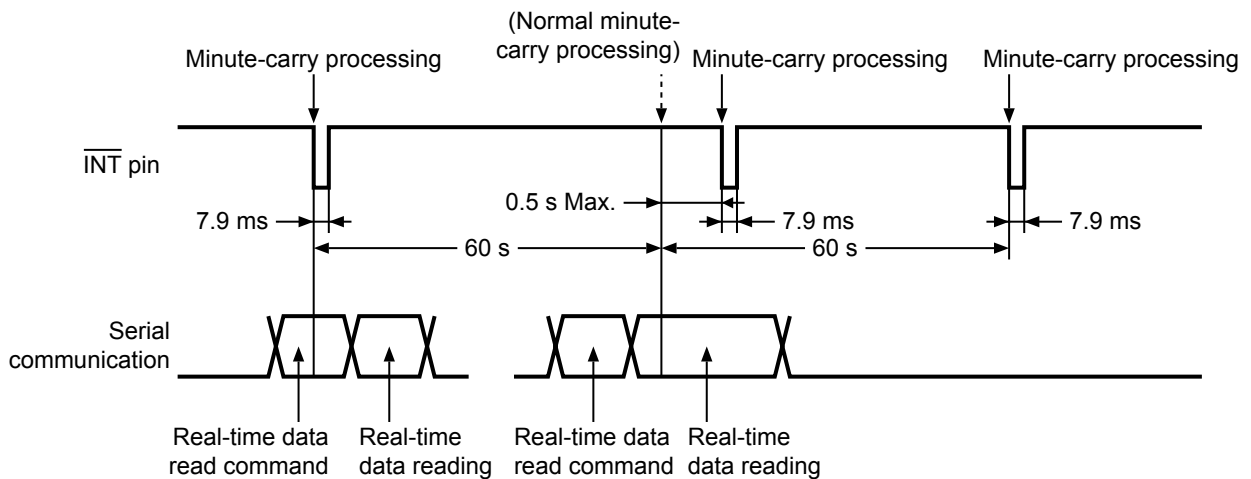

(c) During Write in the real-time data register

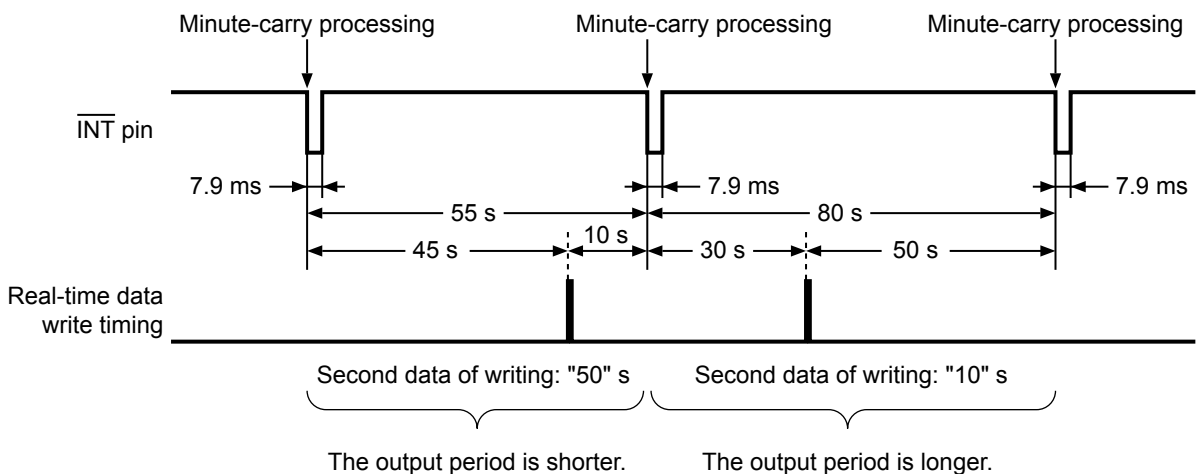

Figure 31 Timing of Minute-periodical Interrupt Output 2

6. Operation of power-on detection circuit

When power is applied to the S-35190A, the power-on detection operates to set “1” in the POC flag (B0 in the status register 1). A 1 Hz clock pulse is output from the $\overline{\text{INT}}$ pin.

Status register 2 setting

32kE = 0, INT1AE = INT1ME = 0,

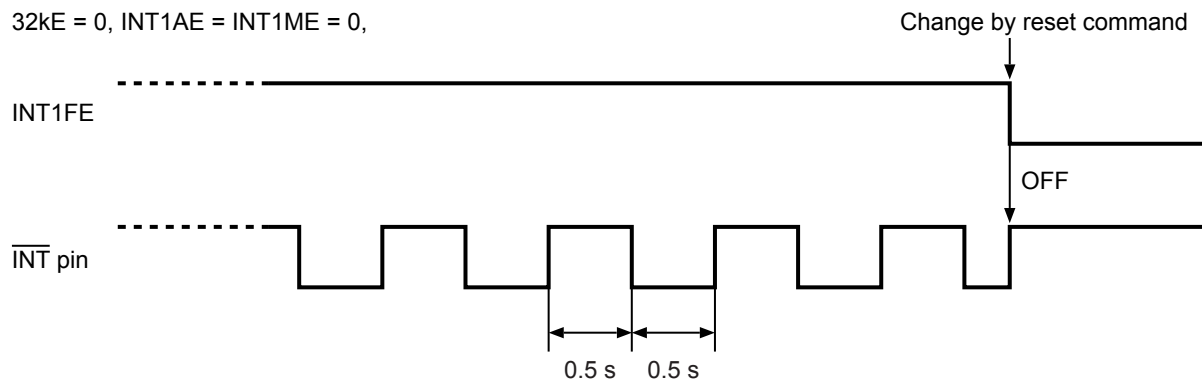

Figure 32 Output Timing of $\overline{\text{INT}}$ Pin during Operation of Power-on Detection Circuit

■ Function to Clock-Correction

The function to clock-correction is to correct advance/delay of the clock due to the deviation of oscillation frequency, in order to make a high precise clock. For correction, the S-35190A adjusts the clock pulse by using a certain part of the dividing circuit, not adjusting the frequency of the crystal oscillator. Correction is performed once every 20 seconds (or 60 seconds). The minimum resolution is approx. 3 ppm (or approx. 1 ppm) and the S-35190A corrects in the range of -195.3 to +192.2 ppm (or of -65.1 to +64.1 ppm). (Refer to **Table 12.**) Users can set up this function by using the clock-correction register. Regarding how to calculate the setting data, refer to “**1. How to calculate**”. When not using this function, be sure to set “00h”.

Table 12 Function to Clock-Correction

	B0 = 0	B0 = 1
Correction	Every 20 seconds	Every 60 seconds
Minimum resolution	3.052 ppm	1.017 ppm
Correction range	-195.3 to +192.2 ppm	-65.1 to +64.1 ppm

1. How to calculate

(1) If current oscillation frequency > target frequency (in case the clock is fast)

$$\text{Correction value}^{*1} = 128 - \text{Integral value} \left(\frac{(\text{Current oscillation frequency actual measurement value}^{*2}) - (\text{Target oscillation frequency}^{*3})}{(\text{Current oscillation frequency actual measurement value}^{*2}) \times (\text{Minimum resolution}^{*4})} \right)$$

Caution The figure range which can be corrected is that the calculated value is from 0 to 64.

- *1. Convert this value to be set in the clock correction register. For how to convert, refer to “(a) Calculation example 1”.
- *2. Measurement value when 1 Hz clock pulse is output from the $\overline{\text{INT}}$ pin.
- *3. Target value of average frequency when the clock correction function is used.
- *4. Refer to **Table 12**.

(a) Calculation example 1

In case of current oscillation frequency actual measurement value = 1.000070 [Hz], target oscillation frequency = 1.000000 [Hz], B7 = 0 (Minimum resolution = 3.052 ppm)

$$\begin{aligned} \text{Correction value} &= 128 - \text{Integral value} \left(\frac{(1.000070) - (1.000000)}{(1.000070) \times (3.052 \times 10^{-6})} \right) \\ &= 128 - \text{Integral value} (22.93) = 128 - 22 = 106 \end{aligned}$$

Convert the correction value “106” to 7-bit binary and obtain “1101010b”.

Reverse the correction value “1101010b” and set it to B6 to B0 of the clock correction register.

Thus, set the clock correction register:

(B7, B6, B5, B4, B3, B2, B1, B0) = (0, 1, 0, 1, 0, 1, 1, 0)

(2) If current oscillation frequency < target frequency (in case the clock is slow)

$$\text{Correction value} = \text{Integral value} \left(\frac{(\text{Target oscillation frequency}) - (\text{Current oscillation frequency actual measurement value})}{(\text{Current oscillation frequency actual measurement value}) \times (\text{Minimum resolution})} \right) + 1$$

Caution The figure range which can be corrected is that the calculated value is from 0 to 62.

(a) Calculation example 2

In case of current oscillation frequency actual measurement value = 0.999920 [Hz], target oscillation frequency = 1.000000 [Hz]. B7 = 0 (Minimum resolution = 3.052 ppm)

$$\begin{aligned} \text{Correction value} &= \text{Integral value} \left(\frac{(1.000000) - (0.999920)}{(0.999920) \times (3.052 \times 10^{-6})} \right) + 1 \\ &= \text{Integral value} (26.21) + 1 = 26 + 1 = 27 \end{aligned}$$

Thus, set the clock correction register:

(B7, B6, B5, B4, B3, B2, B1, B0) = (1, 1, 0, 1, 1, 0, 0, 0)

(b) Calculation example 3

In case of current oscillation frequency actual measurement value = 0.999920 [Hz], target oscillation frequency = 1.000000 [Hz], B7 = 1 (Minimum resolution = 1.017 ppm)

$$\begin{aligned} \text{Correction value} &= \text{Integral value} \left(\frac{(1.000000) - (0.999920)}{(0.999920) \times (1.017 \times 10^{-6})} \right) + 1 \\ &= \text{Integral value} (78.66) + 1 \end{aligned}$$

Thus, this calculated value exceeds the correctable range 0 to 62,

B7 = “1” (minimum resolution = 1.017 ppm) indicates the correction is impossible.

2. Setting value for register and correction value

Table 13 Setting Value for Register and Correction Value (Minimum Resolution: 3.052 ppm (B0 = 0))

B7	B6	B5	B4	B3	B2	B1	B0	Correction Value [ppm]	Rate [s/day]
1	1	1	1	1	1	0	0	192.3	16.61
0	1	1	1	1	1	0	0	189.2	16.35
1	0	1	1	1	1	0	0	186.2	16.09
•								•	•
•								•	•
•								•	•
0	1	0	0	0	0	0	0	6.1	0.53
1	0	0	0	0	0	0	0	3.1	0.26
0	0	0	0	0	0	0	0	0	0
1	1	1	1	1	1	1	0	-3.1	-0.26
0	1	1	1	1	1	1	0	-6.1	-0.53
1	0	1	1	1	1	1	0	-9.2	-0.79
•								•	•
•								•	•
•								•	•
0	1	0	0	0	0	1	0	-189.2	-16.35
1	0	0	0	0	0	1	0	-192.3	-16.61
0	0	0	0	0	0	1	0	-195.3	-16.88

Table 14 Setting Value for Register and Correction Value (Minimum Resolution: 1.017 ppm (B0 = 1))

B7	B6	B5	B4	B3	B2	B1	B0	Correction Value [ppm]	Rate [s/day]
1	1	1	1	1	1	0	1	64.1	5.54
0	1	1	1	1	1	0	1	63.1	5.45
1	0	1	1	1	1	0	1	62.0	5.36
•								•	•
•								•	•
•								•	•
0	1	0	0	0	0	0	1	2.0	0.18
1	0	0	0	0	0	0	1	1.0	0.09
0	0	0	0	0	0	0	1	0	0
1	1	1	1	1	1	1	1	-1.0	-0.09
0	1	1	1	1	1	1	1	-2.0	-0.18
1	0	1	1	1	1	1	1	-3.0	-0.26
•								•	•
•								•	•
•								•	•
0	1	0	0	0	0	1	1	-63.1	-5.45
1	0	0	0	0	0	1	1	-64.1	-5.54
0	0	0	0	0	0	1	1	-65.1	-5.62

3. How to confirm setting value for register and result of correction

The S-35190A does not adjust the frequency of the crystal oscillation by using the clock-correction function. Therefore users cannot confirm if it is corrected or not by measuring output 32.768 kHz. When the function to clock-correction is being used, the cycle of 1 Hz clock pulse output from the INT pin changes once in 20 times or 60 times, as shown in Figure 33.

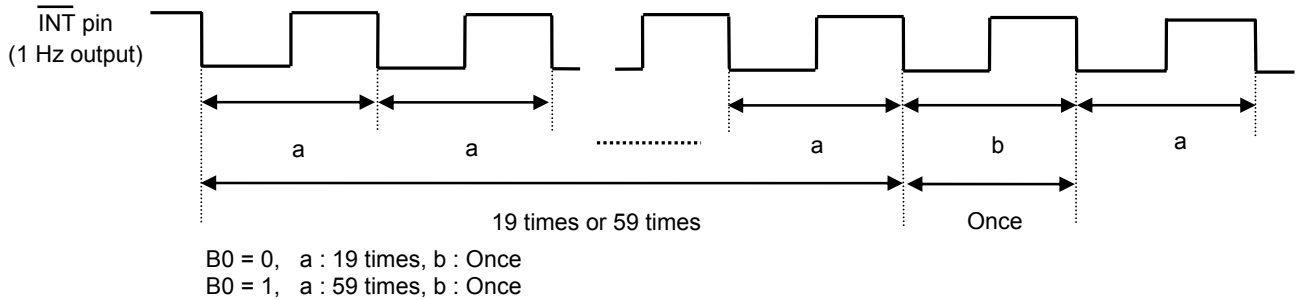

Figure 33 Confirmation of Correction Result

Measure a and b by using the frequency counter*1. Calculate the average frequency (Tave) based on the measurement results.

B0 = 0, $T_{ave} = (a \times 19 + b) \div 20$

B0 = 1, $T_{ave} = (a \times 59 + b) \div 60$

Calculate the error of the clock based on the average frequency (Tave). The following shows an example for confirmation.

Confirmation example: When B0 = 0, 66h is set

Measurement results: a = 1.000080 Hz, b = 0.998493 Hz

	Clock Correction Register Setting Value	Average frequency [Hz]	Per Day [s]
Before correction	00 h (Tave = a)	1.000080	86393
After correction	66 h (Tave = (a × 19 + b) ÷ 20)	1.00000065	86399.9

Calculating the average frequency allows to confirm the result of correction.

*1. Use a high-accuracy frequency counter of 7 digits or more.

Caution Measure the oscillation frequency under the usage conditions.

■ **Serial Interface**

The S-35190A receives various commands via 3-wire serial interface to Read/Write data. Regarding transmission is as follows.

1. Data Read

When data is input from the SIO pin in synchronization with the falling of the $\overline{\text{SCK}}$ clock after setting the CS pin to "H", the data is loaded internally in synchronization with the next rising of the $\overline{\text{SCK}}$ clock. When $\text{R}/\overline{\text{W}}$ bit = "1" is loaded at the eighth rising of the $\overline{\text{SCK}}$ clock, the state of data reading is entered. Data corresponding to each command is then output in synchronization with the falling of the subsequent $\overline{\text{SCK}}$ clock input. When the $\overline{\text{SCK}}$ clock is less than 8, the IC is in the clock-wait status, and no processing is performed.

2. Data Write

When data is input from the SIO pin in synchronization with the falling of the $\overline{\text{SCK}}$ clock after setting the CS pin to "H", the data is loaded internally in synchronization with the next rising of the $\overline{\text{SCK}}$ clock. When $\text{R}/\overline{\text{W}}$ bit = "0" is loaded at the eighth rising of the $\overline{\text{SCK}}$ clock, the state of data writing is entered. In this state, the data, which is input in synchronization with the falling of the subsequent $\overline{\text{SCK}}$ clock input, is written to registers according to each command. In data Write, input a clock pulse which is equivalent to the byte of the register. As well as in Read, when the $\overline{\text{SCK}}$ clock is less than 8, the IC is in the clock-wait status, and no processing is performed.

3. Data access

(1) Real-time data 1 access

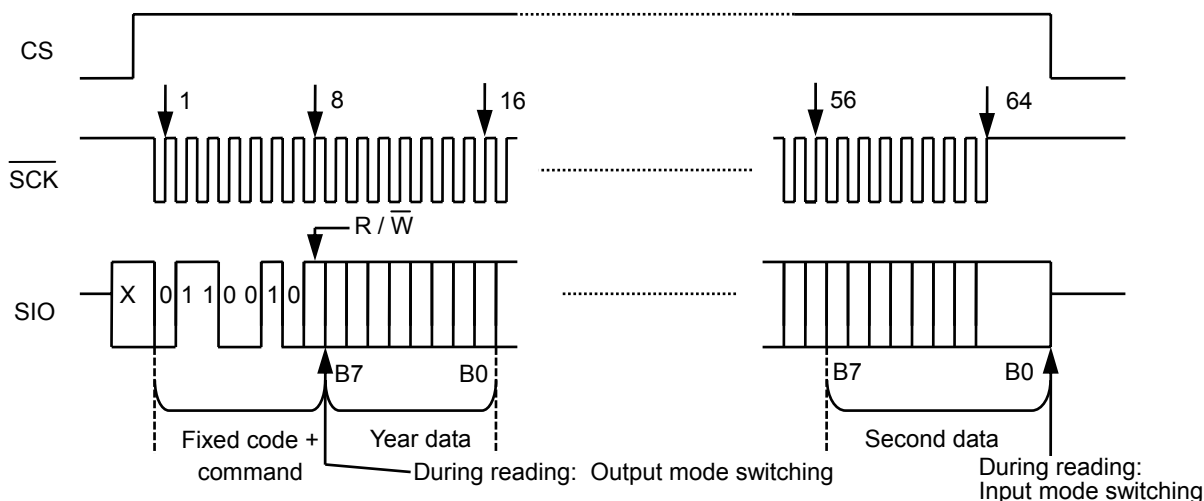

Figure 34 Real-Time Data Access 1

(2) Real-time data 2 access

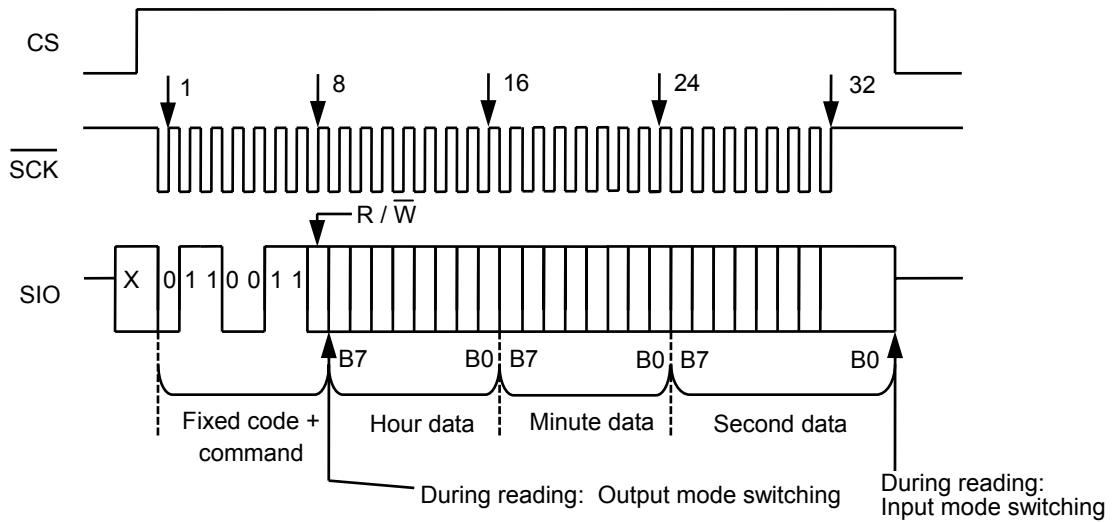
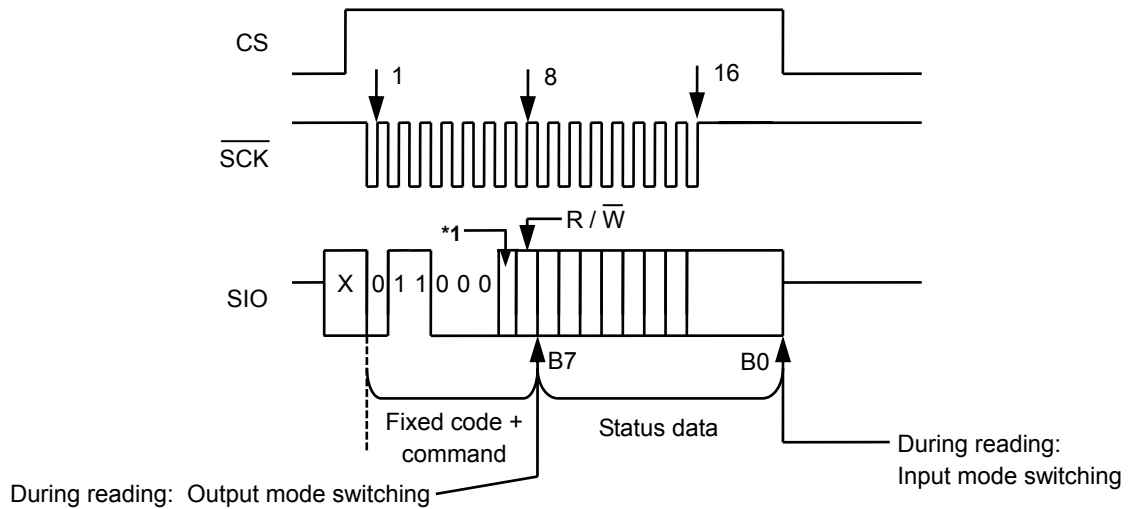

Figure 35 Real-Time Data 2 Access

(3) Status register 1 access and status register 2 access



- *1. 0 : Status register 1 selected
- 1 : Status register 2 selected

Figure 36 Status Register 1 Access and Status Register 2 Access

(4) INT register 1 access and INT register 2 access

In Read/Write the INT register 1, data varies depending on the setting of the status register 2. Be sure to Read/Write the INT register 1 after setting the status register 2. When setting the alarm by using the status register 2, these registers work as 3-byte alarm time data registers, in other statuses, they work as 1-byte registers. When outputting the user-set frequency, they are the data registers to set up the frequency.

Read/Write the INT register 2 after setting INT2AE in the status register 2. When INT2AE is in "1", the INT register 2 works as for setting the 3-byte alarm time data. The INT register 2 does not have the function to output the user-set frequency. Regarding details of each data, refer to "4. INT register 1 and INT register 2" in "■ Configuration of Register".

Caution Users cannot use both functions of alarm 1 interrupt and the output of user-set frequency simultaneously.

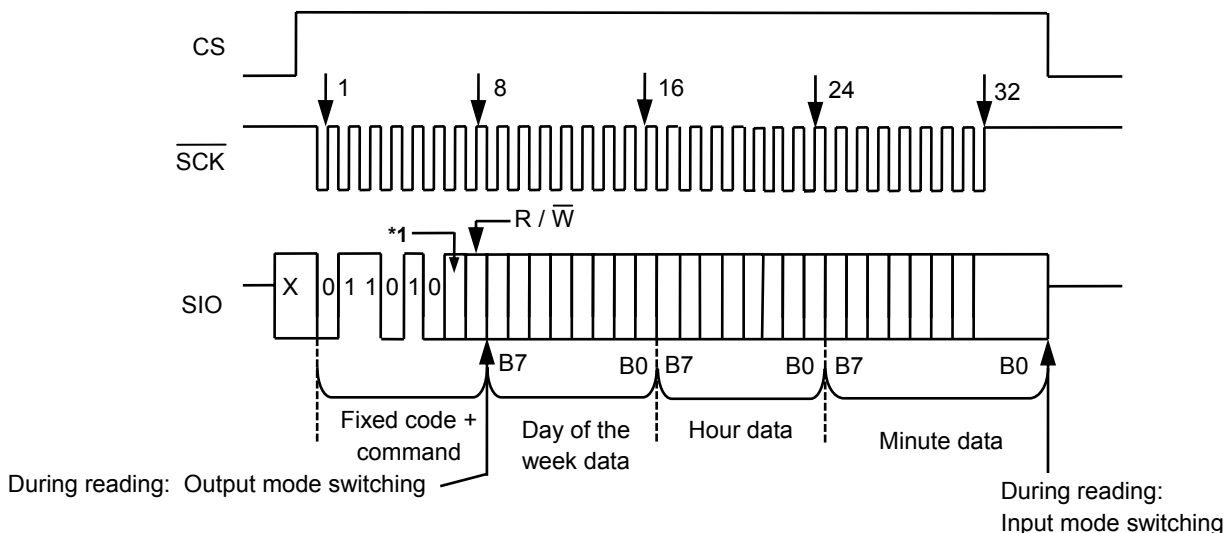

*1. 0 : INT register 1 selected
1 : INT register 2 selected

Figure 37 INT Register 1 Access and INT Register 2 Access

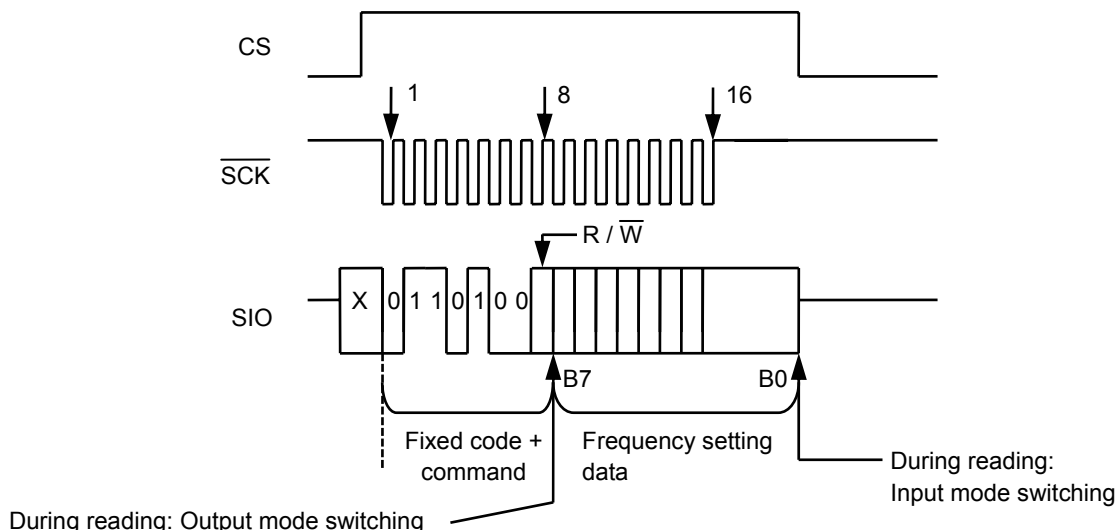

Figure 38 INT Register 1 (Data Register for output frequency) Access

(5) Clock correction register access

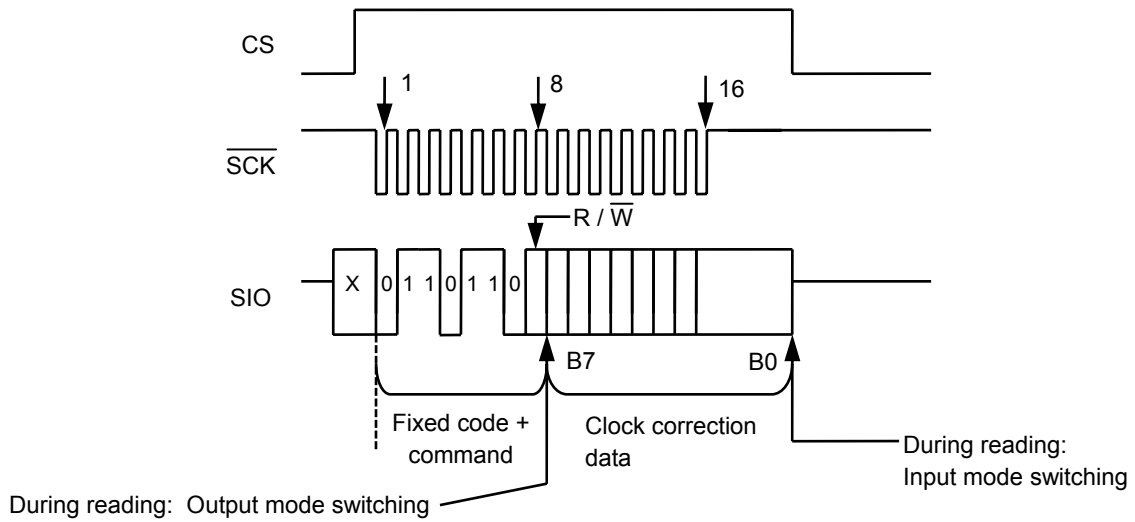

Figure 39 Clock Correction Register Access

(6) Free register access

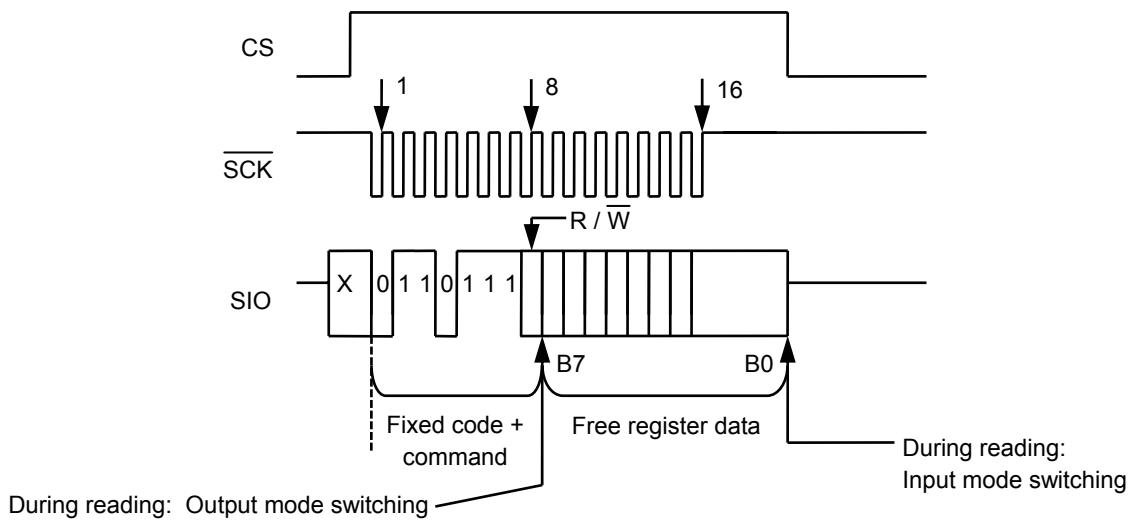

Figure 40 Free Register Access

■ Flowchart of Initialization at Power-on and Example of Real-time Data Set-up

Figure 41 shows the flowchart of initialization at power-on and an example of real-time data set-up. Regarding how to apply power, refer to “■ Power-on Detection Circuit and Register Status”. It is unnecessary for users to comply with this flowchart of real-time data strictly. And if using the default data at initializing, it is also unnecessary to set up again.

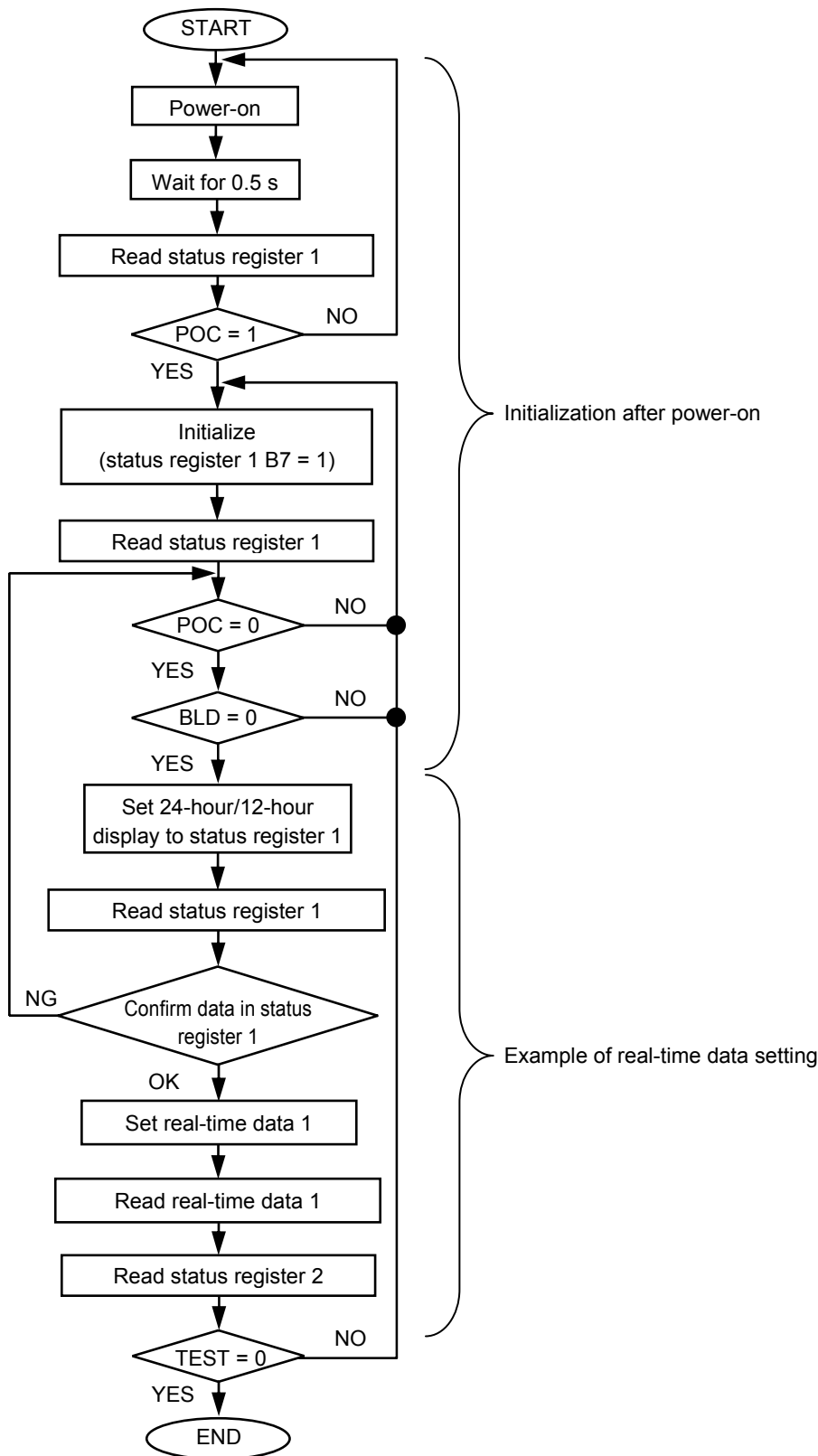
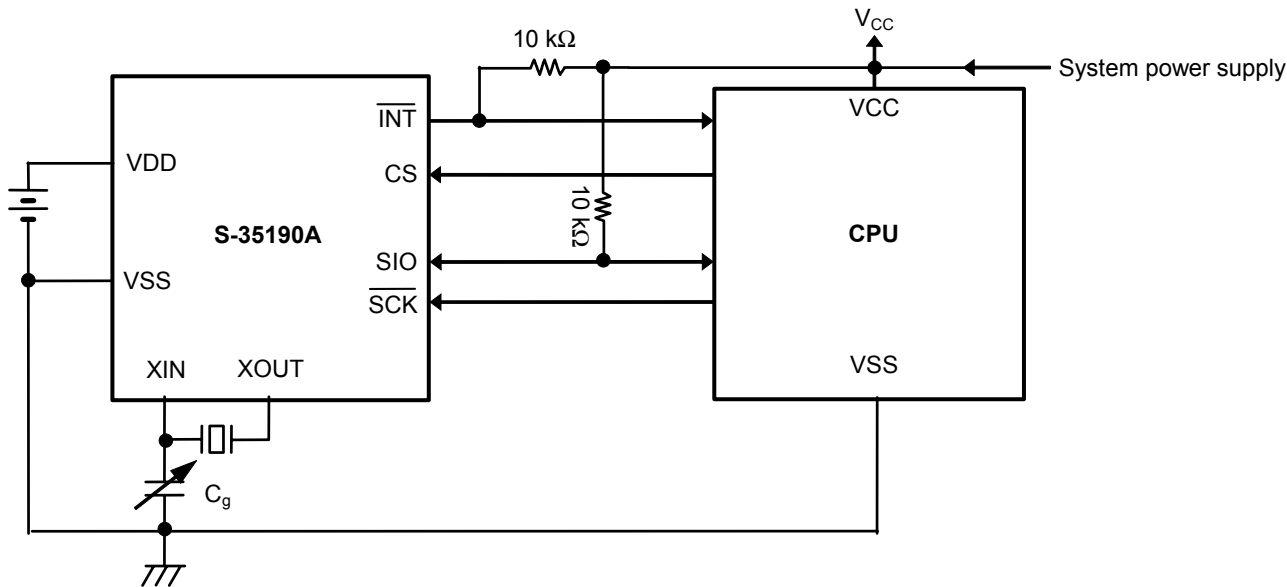

Figure 41 Example of Initialization Flowchart
Seiko Instruments Inc.

■ Examples of Application Circuits



- Caution**
1. Because the I/O pin has no protective diode on the VDD side, the relation of $V_{CC} \geq V_{DD}$ is possible. But pay careful attention to the specifications.
 2. Start communication under stable condition after power-on the power supply in the system.

Figure 42 Application Circuit 1

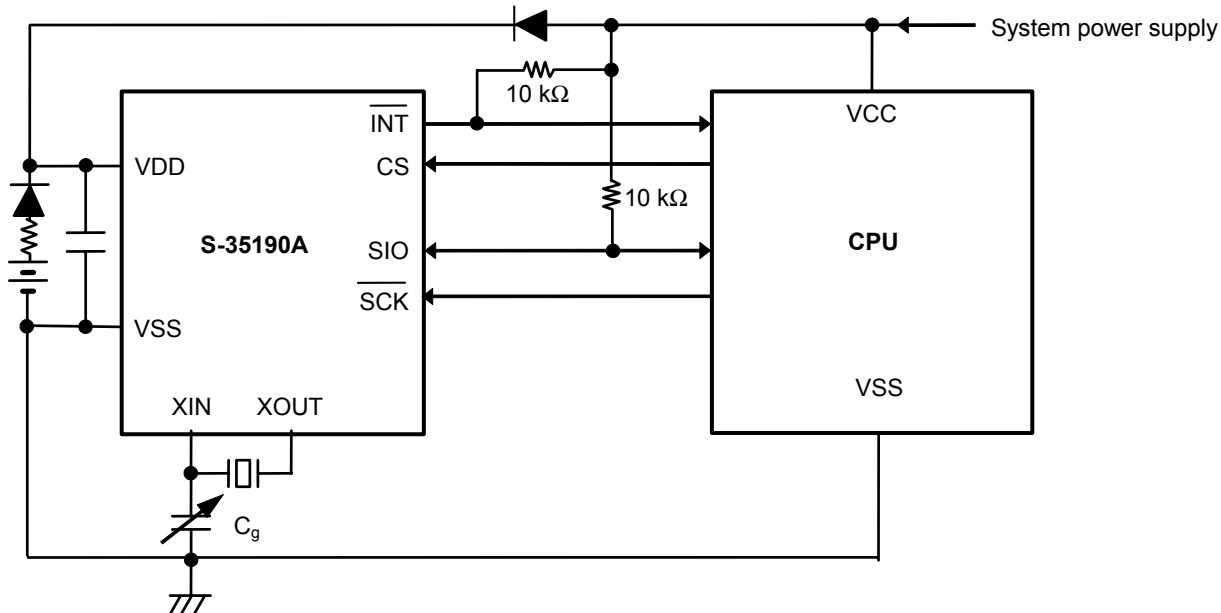

Caution Start communication under stable condition after power-on the power supply in the system.

Figure 43 Application Circuit 2

Caution The above connection diagrams do not guarantee operation. Set the constants after performing sufficient evaluation using the actual application.

■ Adjustment of Oscillation Frequency

1. Configuration of oscillation

Since crystal oscillation is sensitive to external noise (the clock accuracy is affected), the following measures are essential for optimizing the oscillation configuration.

- (1) Place the S-35190A, crystal oscillator, and external capacitor (C_g) as close to each other as possible.
- (2) Increase the insulation resistance between pins and the substrate wiring patterns of XIN and XOUT.
- (3) Do not place any signal or power lines close to the oscillator.
- (4) Locating the GND layer immediately below the oscillator is recommended.
- (5) Locate the bypass capacitor adjacent to the power supply pin of the S-35190A.

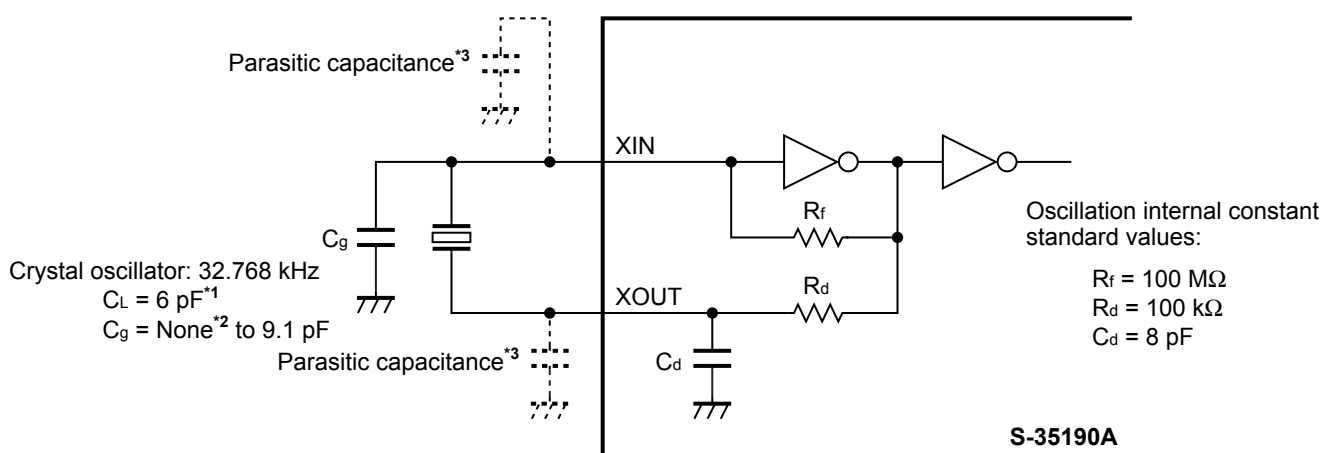

- *1. When setting the value for the crystal oscillator's C_L as 7 pF, connect C_d externally if necessary.
- *2. Design the board so that the parasitic capacitance is 5 pF.
- *3. The oscillator operates unless C_g is not connected. Note that the oscillation frequency is in the direction that it advances.

Figure 44 Connection Diagram 1

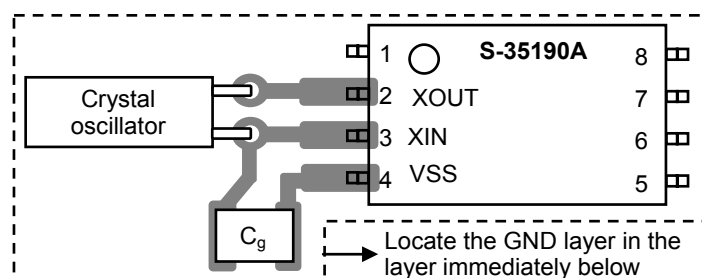

Figure 45 Connection Diagram 2

- Caution**
1. When using the crystal oscillator with a C_L exceeding the rated value (7 pF) (e.g : $C_L = 12.5$ pF), oscillation operation may become unstable. Use a crystal oscillator with a C_L value of 6 pF or 7 pF.
 2. Oscillation characteristics are subject to the variation of each component such as substrate parasitic capacitance, parasitic resistance, crystal oscillator, and C_g . When configuring oscillator, pay sufficient attention for them.

2. Measurement of oscillation frequency

When the S-35190A is turned on, the internal power-on detector operates and a signal of 1 Hz is output from the $\overline{\text{INT}}$ pin to select the crystal oscillator and optimize the C_g value. Turn the power on and measure the signal with a frequency counter following the circuit configuration shown in **Figure 46**.

If 1 Hz signal is not output, the power-on detector does not operate normally. Turn off the power and then turn it on again. For how to apply power, refer to “**■ Power-on Detector and Register Status**”.

Remark If the error range is ± 1 ppm in relation to 1 Hz, the time is shifted by approximately 2.6 seconds per month (calculated using the following expression).

$$10^{-6} (1 \text{ ppm}) \times 60 \text{ seconds} \times 60 \text{ minutes} \times 24 \text{ hours} \times 30 \text{ days} = 2.592 \text{ seconds}$$

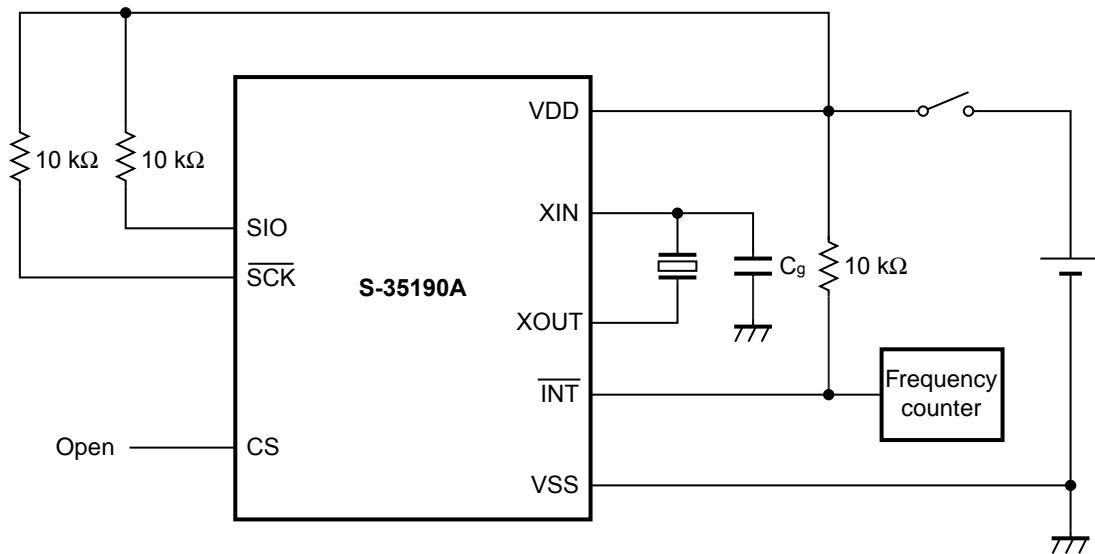

Figure 46 Configuration of Oscillation Frequency Measurement Circuit

- Caution**
1. Use a high-accuracy frequency counter of 7 digits or more.
 2. Measure the oscillation frequency under the usage conditions.
 3. Since the 1 Hz signal continues to be output, initialization must be executed during normal operation.

3. Adjustment of oscillation frequency

(1) Adjustment by setting C_g

Matching of the crystal oscillator with the nominal frequency must be performed with the stray capacitance on the board included. Select a crystal oscillator and optimize the C_g value in accordance with the flowchart below.

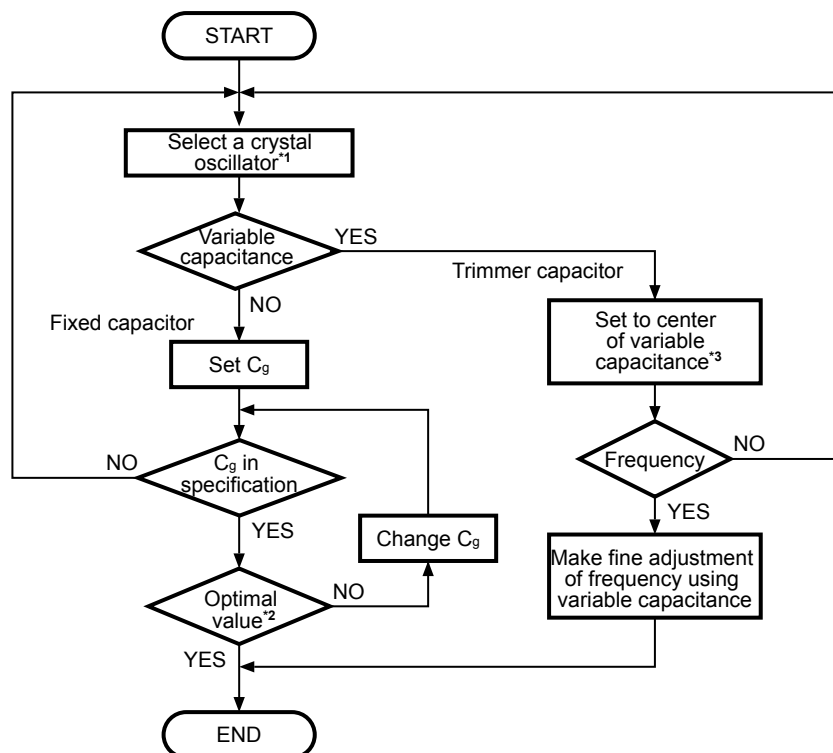

*1. Request a crystal manufacturer for matching evaluation between the IC and a crystal. The recommended crystal characteristic values are, C_L value (load capacitance) = 6 pF, R_1 value (equivalent serial resistance) = 50 k Ω max.

*2. The C_g value must be selected on the actual PCB since it is affected by stray capacitance. Select the external C_g value in a range of 0 pF to 9.1 pF.

*3. Adjust the rotation angle of the variable capacitance so that the capacitance value is slightly smaller than the center, and confirm the oscillation frequency and the center value of the variable capacitance. This is done in order to make the capacitance of the center value smaller than one half of the actual capacitance value because a smaller capacitance value increases the frequency variation.

Figure 47 Crystal Oscillator Setting Flow

- Caution**
1. The oscillation frequency varies depending on the ambient temperature and power supply voltage. Refer to “■ Characteristics (Typical Data)”.
 2. The 32.768 kHz crystal oscillator operates more slowly at an operating temperature than higher or lower 20 to 25°C. Therefore, it is recommended to set the oscillator to operate slightly faster at normal temperature.

■ Product Name Structure

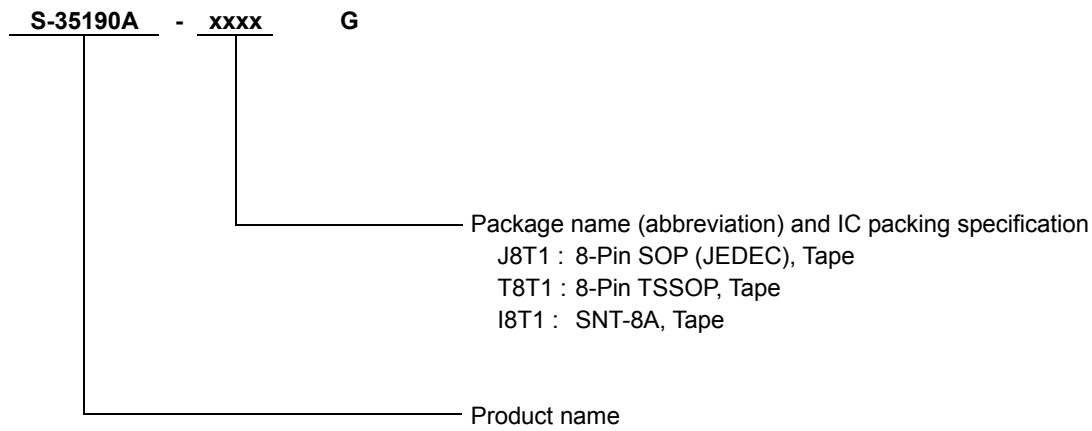

■ Precautions

- Although the IC contains a static electricity protection circuit, static electricity or voltage that exceeds the limit of the protection circuit should not be applied.
- Seiko Instruments Inc. assumes no responsibility for the way in which this IC is used in products created using this IC or for the specifications of that product, nor does Seiko Instruments Inc. assume any responsibility for any infringement of patents or copyrights by products that include this IC either in Japan or in other countries.

■ Characteristics (Typical Data)

(1) Standby current vs. V_{DD} characteristics

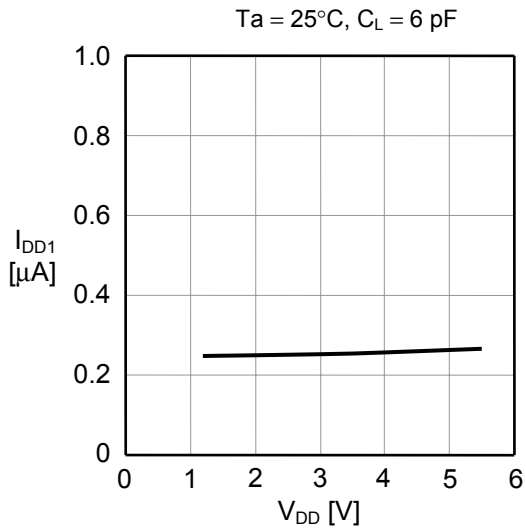

(2) Current consumption when 32.768 kHz is output vs. V_{DD} characteristics

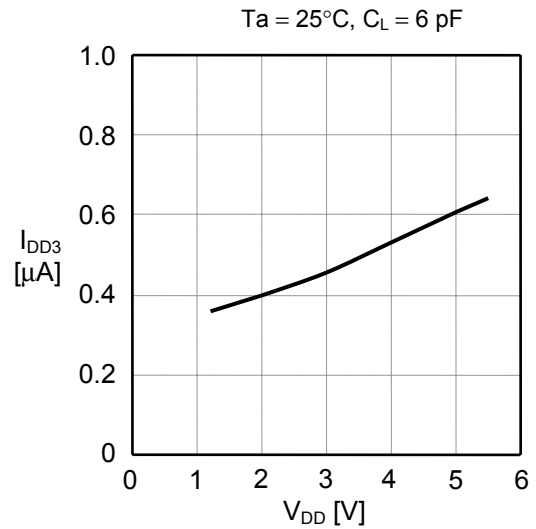

(3) Current consumption during operation vs. Input clock characteristics

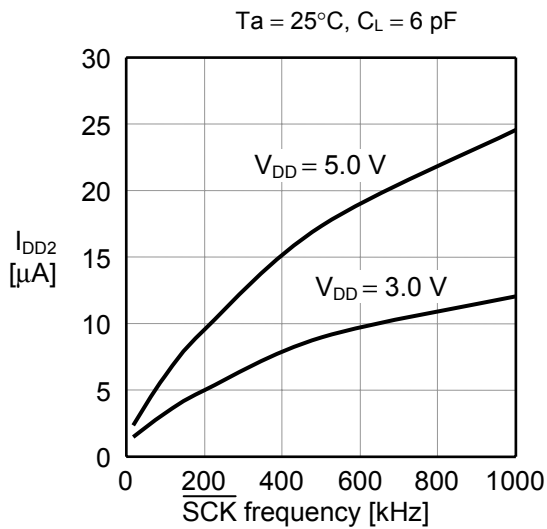

(4) Standby current vs. Temperature characteristics

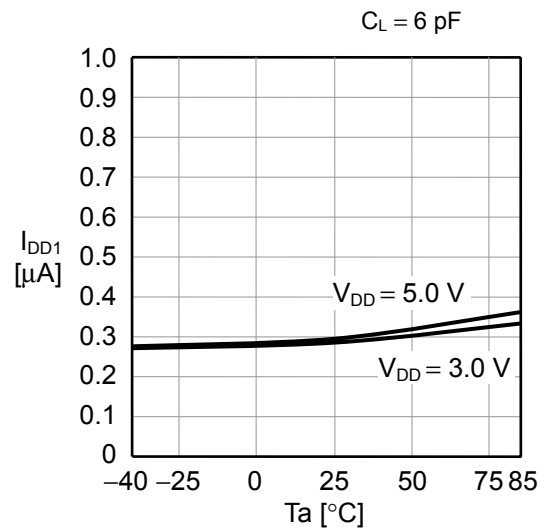

(5) Standby current vs. C_g characteristics

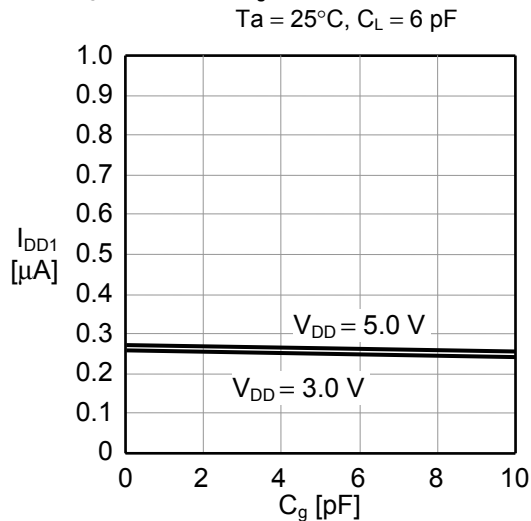

(6) Oscillation frequency vs. C_g characteristics

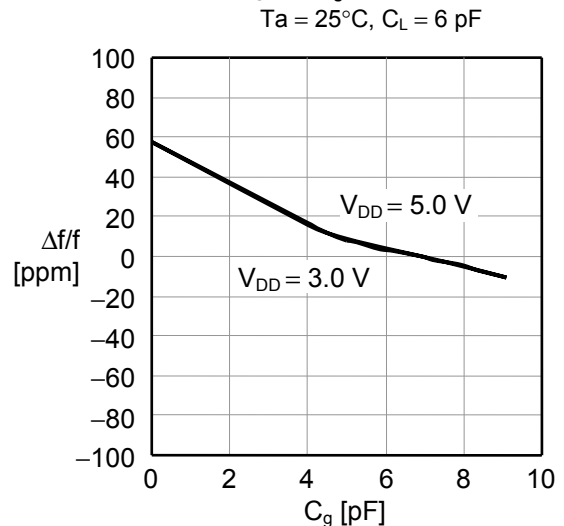

(7) Oscillation frequency vs. V_{DD} characteristics

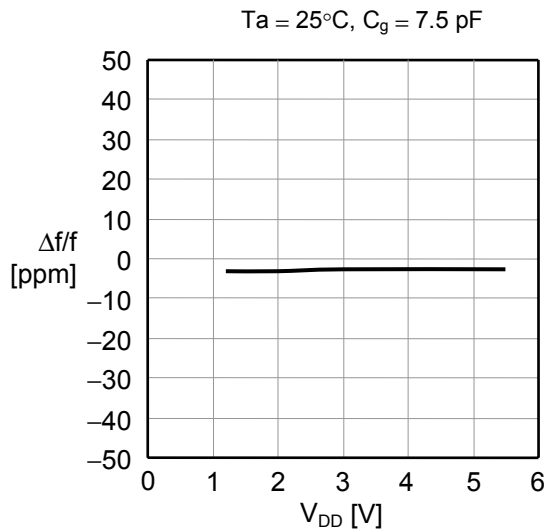

(8) Oscillation frequency vs. Temperature characteristics

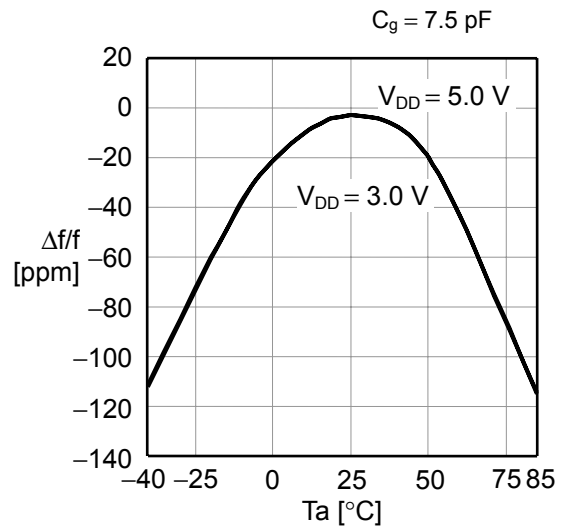

(9) Oscillation start time vs. C_g characteristics

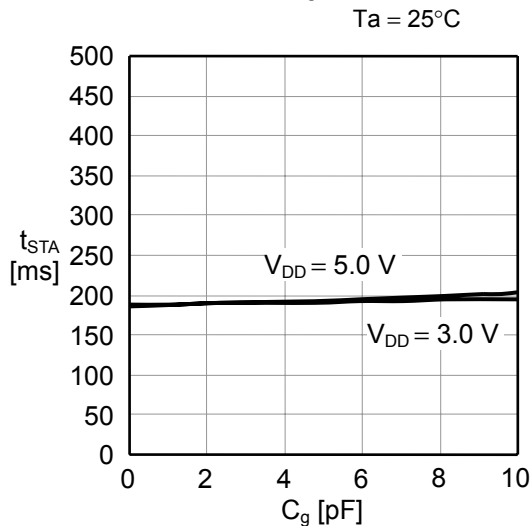

(10) Output current characteristics 1 (V_{OUT} vs. I_{OL1})
INT pin, $T_a = 25^\circ\text{C}$

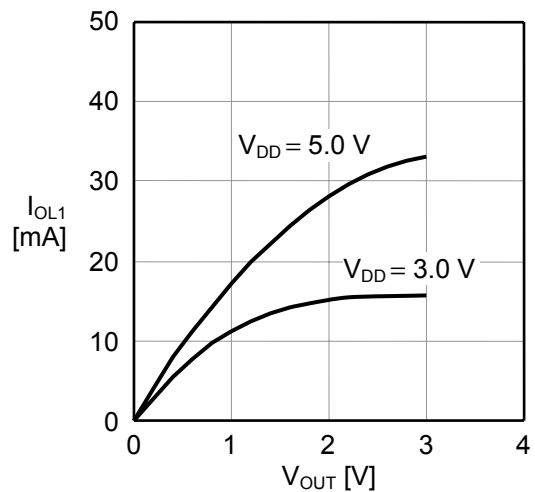

(11) Output current characteristics 2 (V_{OUT} vs. I_{OL2})
SIO pin, $T_a = 25^\circ\text{C}$

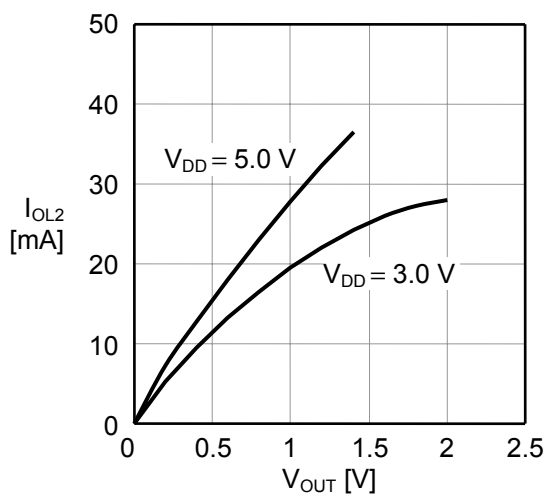

(12) CS pin input current characteristics
CS pin, $T_a = 25^\circ\text{C}$

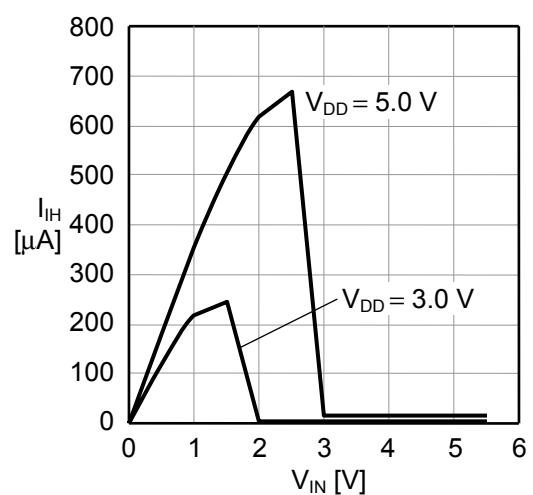

(13) BLD detection, release voltage, V_{DDT} (Min) vs. Temperature characteristics

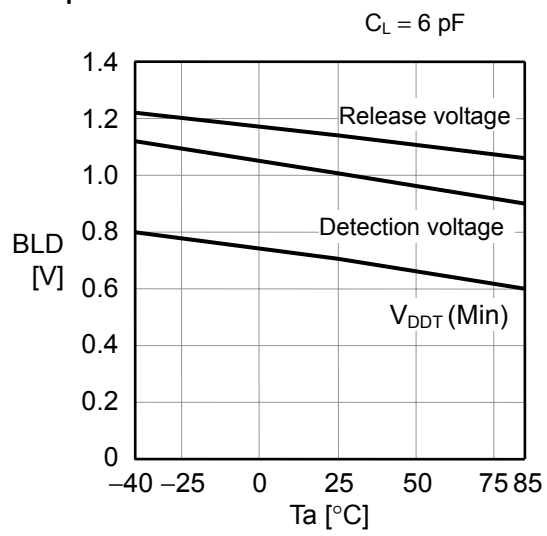

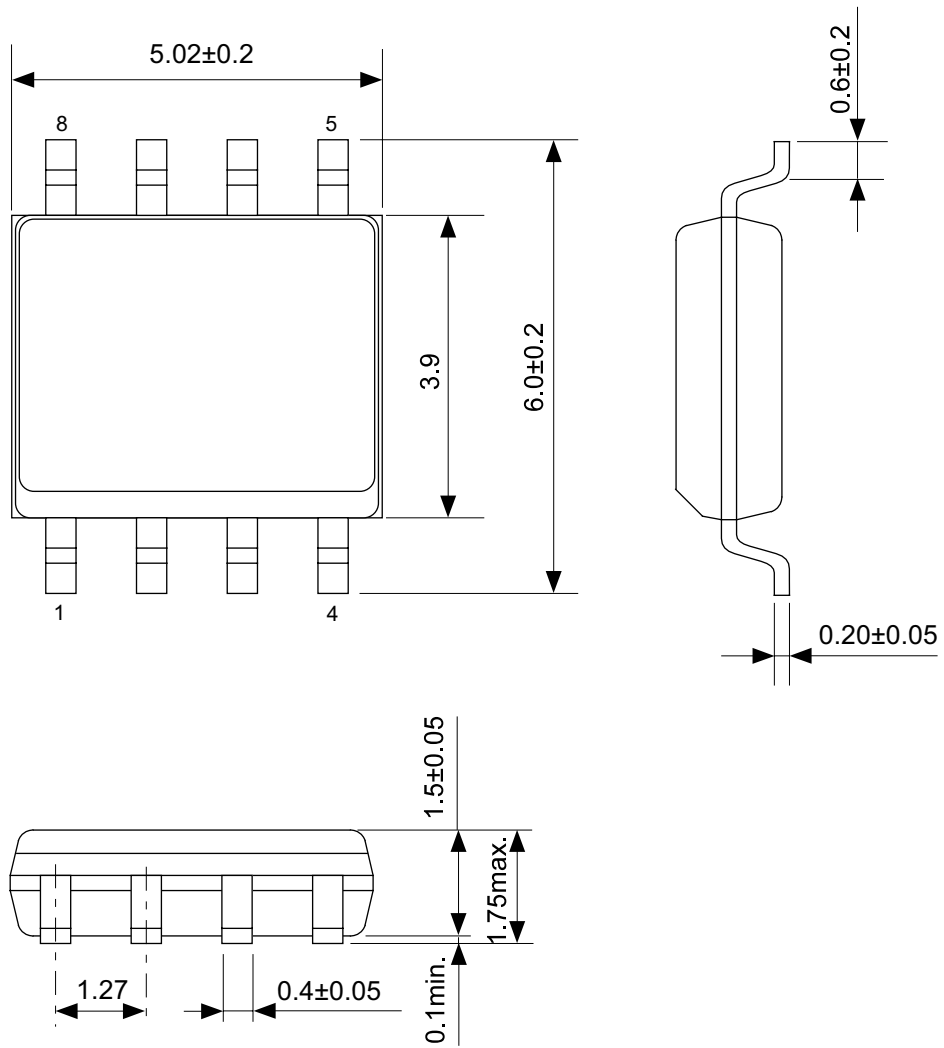

No. FJ008-A-P-SD-2.1

TITLE	SOP8J-D-PKG Dimensions
No.	FJ008-A-P-SD-2.1
SCALE	
UNIT	mm
Seiko Instruments Inc.	

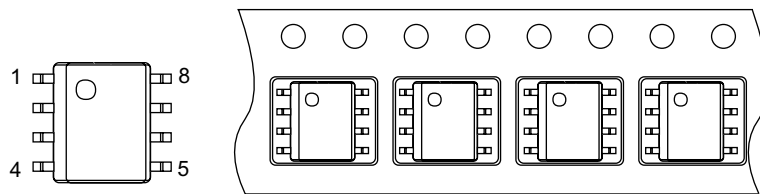
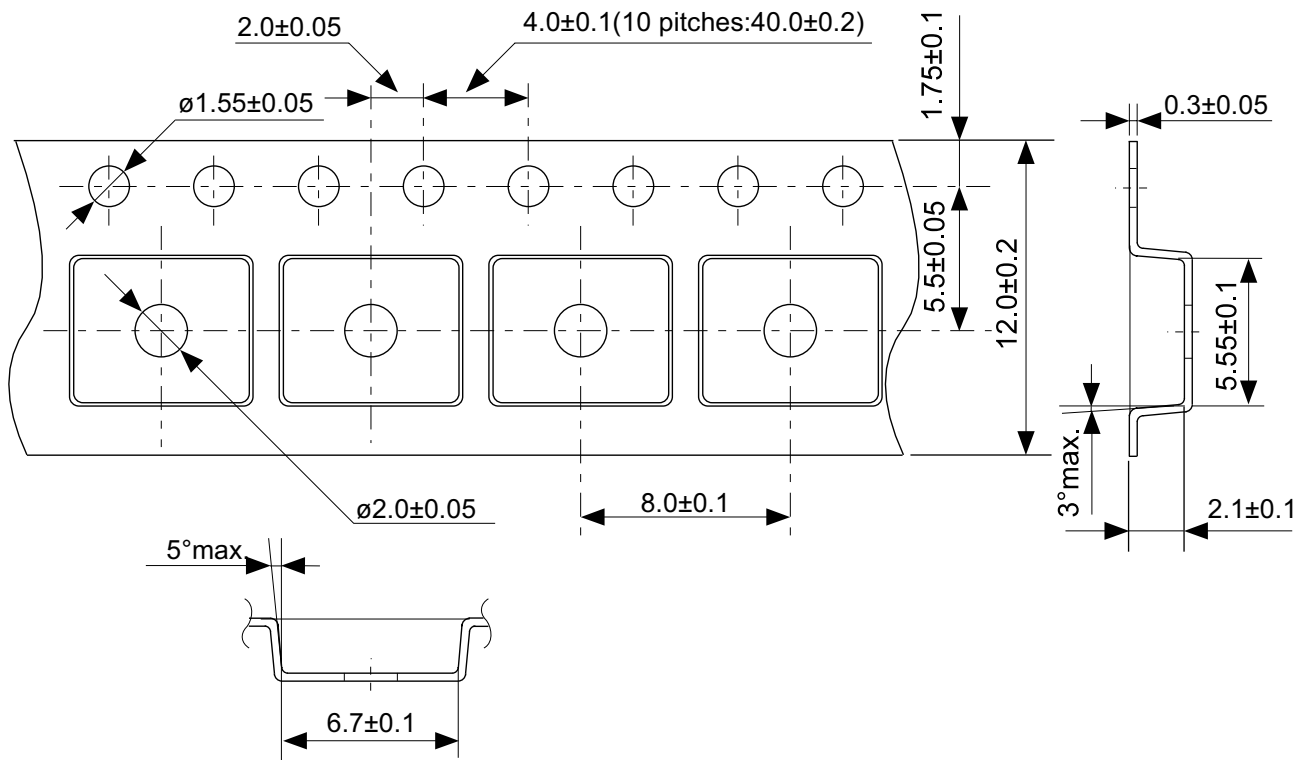

No. FJ008-D-C-SD-1.1

TITLE	SOP8J-D-Carrier Tape
No.	FJ008-D-C-SD-1.1
SCALE	
UNIT	mm
Seiko Instruments Inc.	

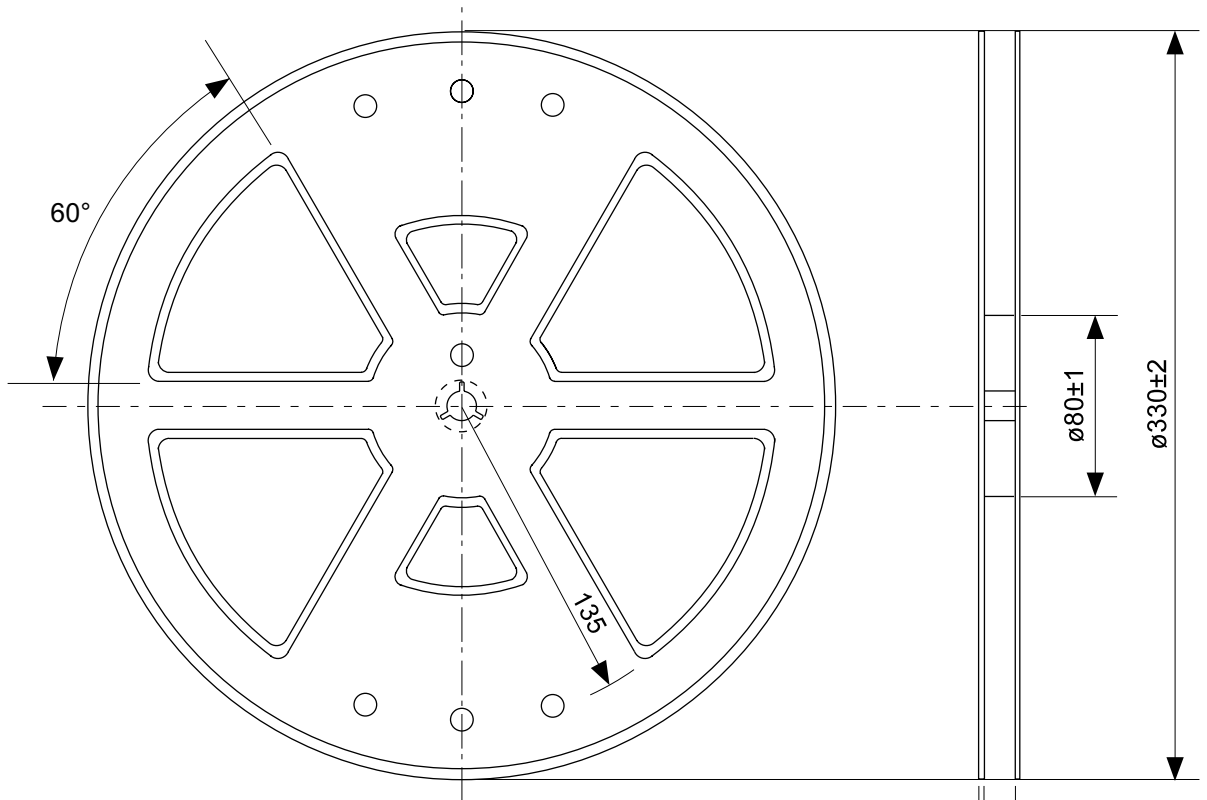

Enlarged drawing in the central part

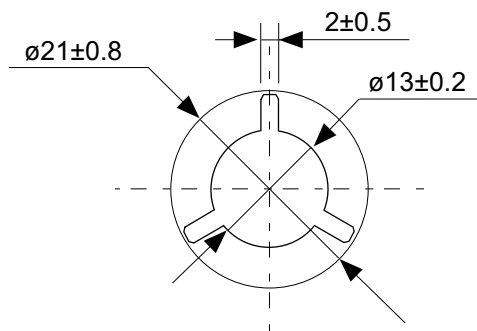

No. FJ008-D-R-SD-1.1

TITLE	SOP8J-D-Reel		
No.	FJ008-D-R-SD-1.1		
SCALE		QTY.	2,000
UNIT	mm		
Seiko Instruments Inc.			

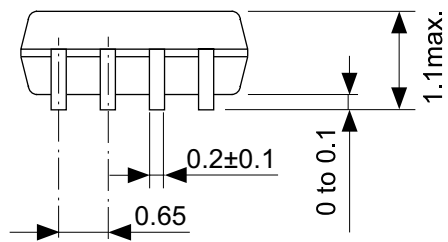
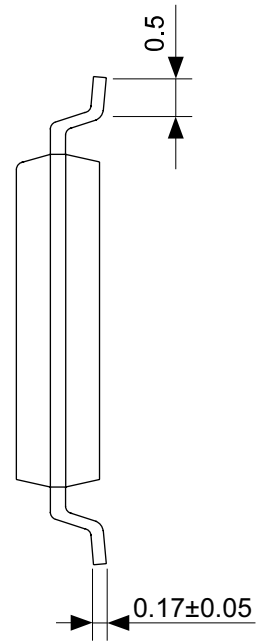
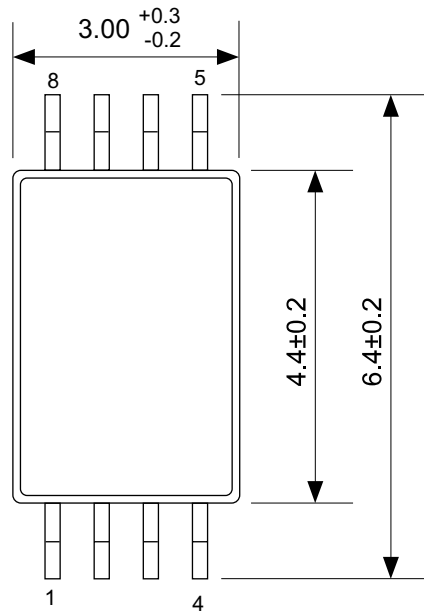

No. FT008-A-P-SD-1.1

TITLE	TSSOP8-E-PKG Dimensions
No.	FT008-A-P-SD-1.1
SCALE	
UNIT	mm
Seiko Instruments Inc.	

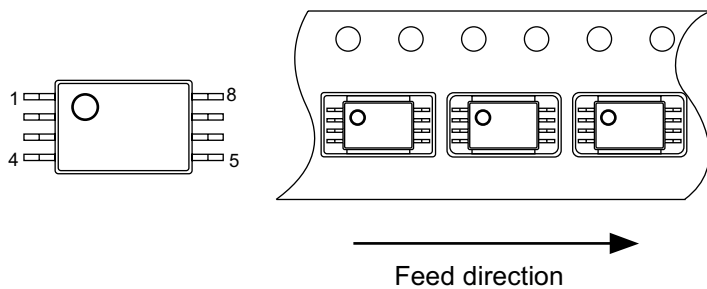
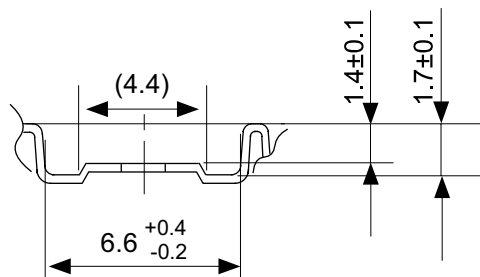
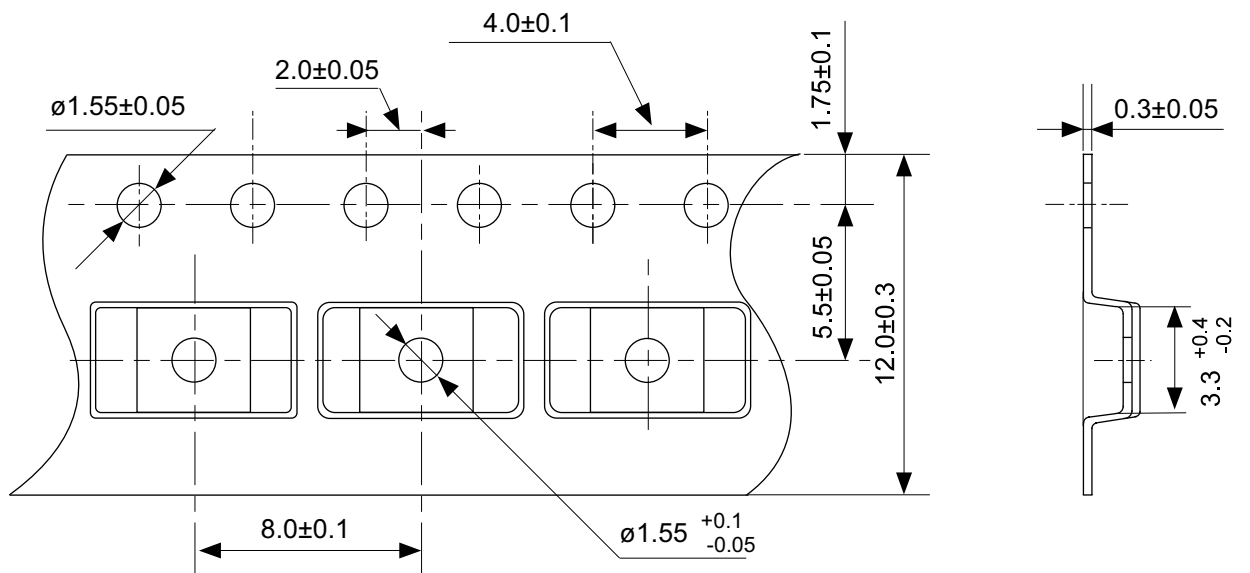

No. FT008-E-C-SD-1.0

TITLE	TSSOP8-E-Carrier Tape
No.	FT008-E-C-SD-1.0
SCALE	
UNIT	mm
Seiko Instruments Inc.	

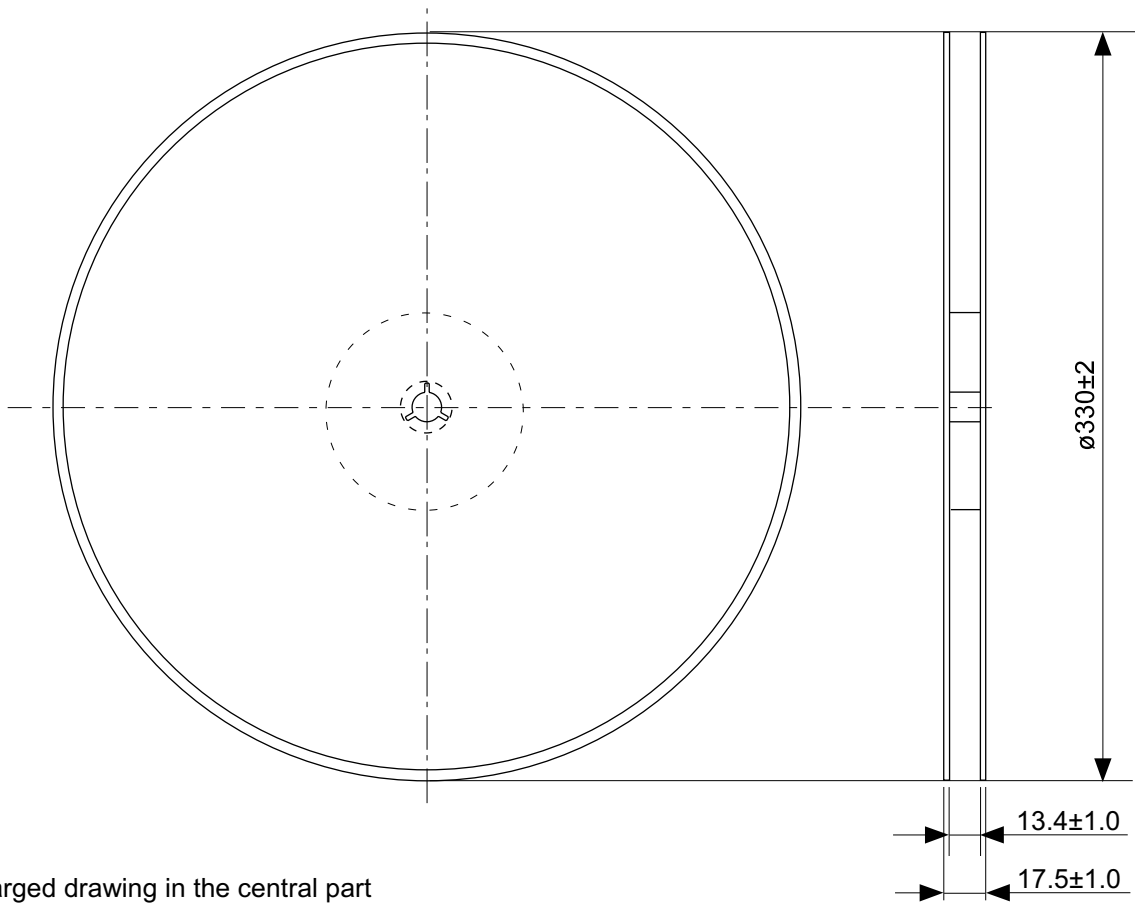

Enlarged drawing in the central part

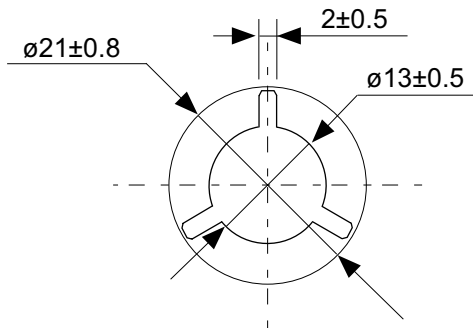

No. FT008-E-R-SD-1.0

TITLE	TSSOP8-E-Reel		
No.	FT008-E-R-SD-1.0		
SCALE		QTY.	3,000
UNIT	mm		
Seiko Instruments Inc.			

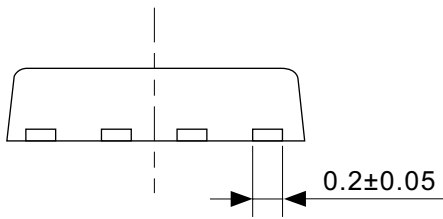
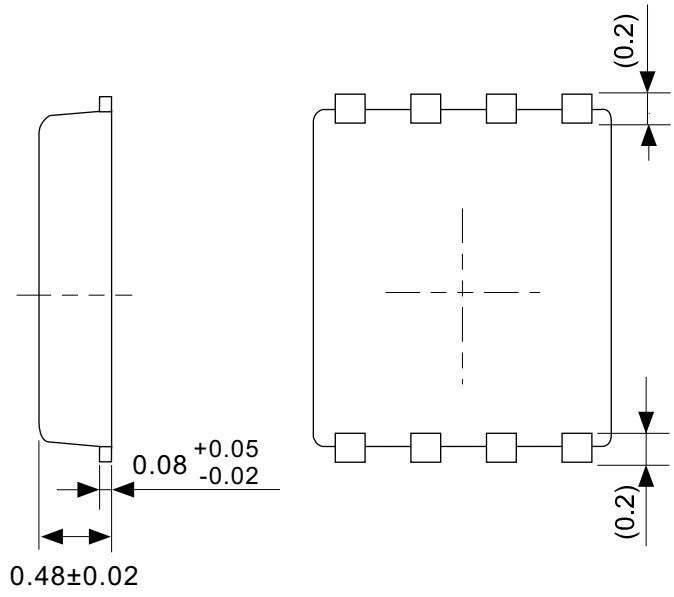
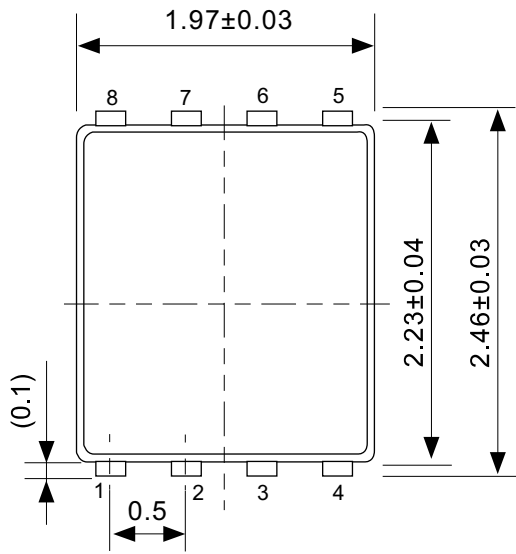

No. PH008-A-P-SD-2.0

TITLE	SNT-8A-A-PKG Dimensions
No.	PH008-A-P-SD-2.0
SCALE	
UNIT	mm
Seiko Instruments Inc.	

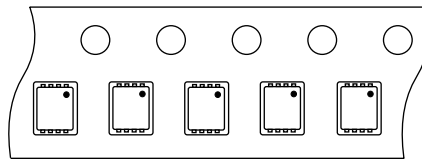
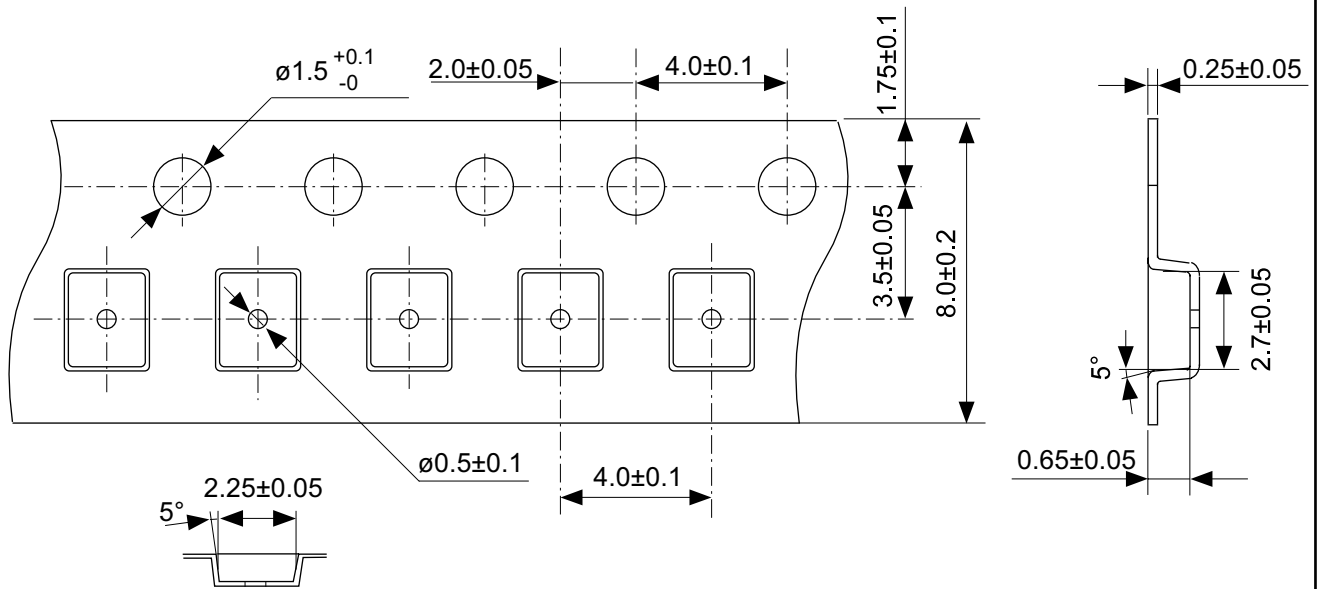

Feed direction

No. PH008-A-C-SD-1.0

TITLE	SNT-8A-A-Carrier Tape
No.	PH008-A-C-SD-1.0
SCALE	
UNIT	mm
Seiko Instruments Inc.	

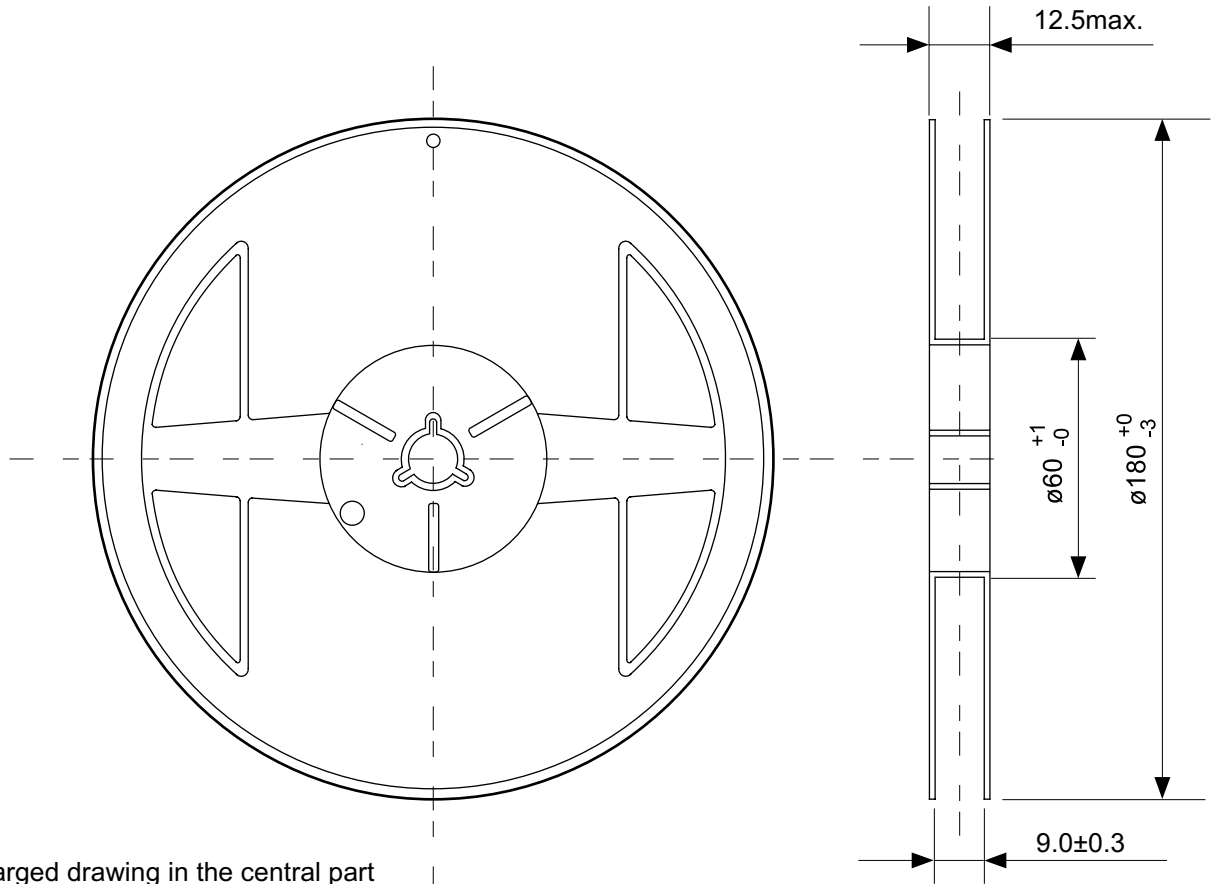

Enlarged drawing in the central part

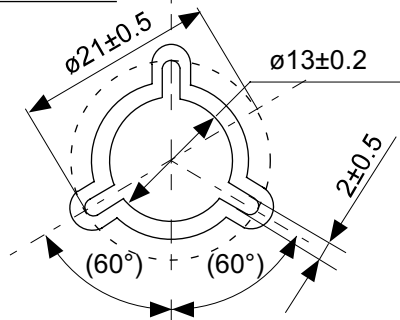

No. PH008-A-R-SD-1.0

TITLE	SNT-8A-A-Reel		
No.	PH008-A-R-SD-1.0		
SCALE		QTY.	5,000
UNIT	mm		
Seiko Instruments Inc.			

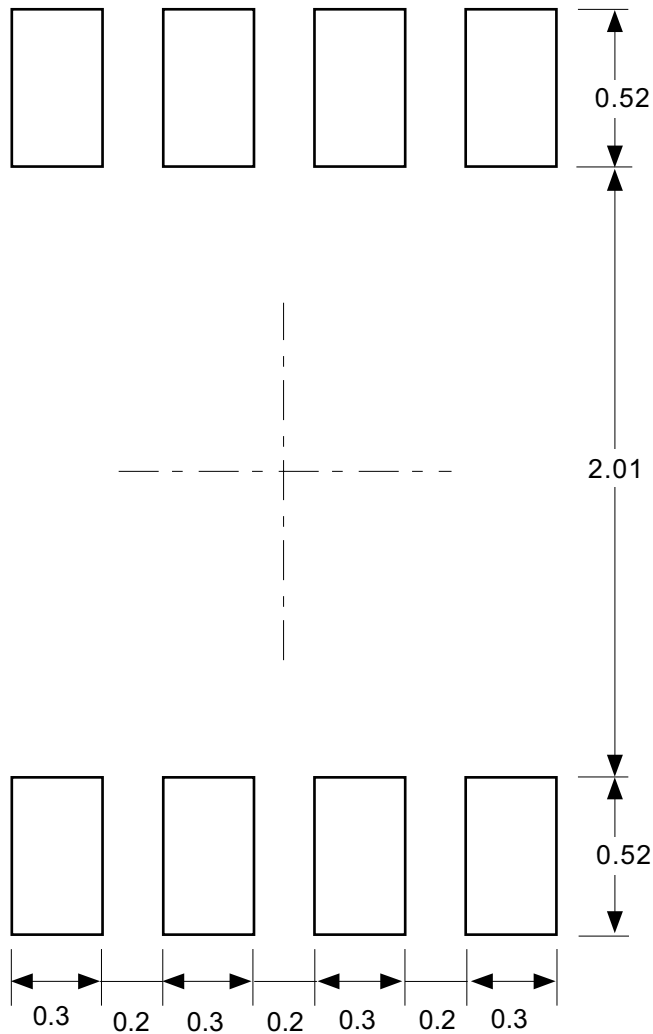

Caution Making the wire pattern under the package is possible. However, note that the package may be upraised due to the thickness made by the silk screen printing and of a solder resist on the pattern because this package does not have the standoff.

注意 パッケージ下への配線パターン形成は可能ですが、本パッケージはスタンドオフが無いので、パターン上のレジスト厚み、シルク印刷の厚みによってパッケージが持ち上がる場合がありますのでご配慮ください。

No. PH008-A-L-SD-3.0

TITLE	SNT-8A-A-Land Recommendation
No.	PH008-A-L-SD-3.0
SCALE	
UNIT	mm
Seiko Instruments Inc.	

- The information described herein is subject to change without notice.
- Seiko Instruments Inc. is not responsible for any problems caused by circuits or diagrams described herein whose related industrial properties, patents, or other rights belong to third parties. The application circuit examples explain typical applications of the products, and do not guarantee the success of any specific mass-production design.
- When the products described herein are regulated products subject to the Wassenaar Arrangement or other agreements, they may not be exported without authorization from the appropriate governmental authority.
- Use of the information described herein for other purposes and/or reproduction or copying without the express permission of Seiko Instruments Inc. is strictly prohibited.
- The products described herein cannot be used as part of any device or equipment affecting the human body, such as exercise equipment, medical equipment, security systems, gas equipment, or any apparatus installed in airplanes and other vehicles, without prior written permission of Seiko Instruments Inc.
- Although Seiko Instruments Inc. exerts the greatest possible effort to ensure high quality and reliability, the failure or malfunction of semiconductor products may occur. The user of these products should therefore give thorough consideration to safety design, including redundancy, fire-prevention measures, and malfunction prevention, to prevent any accidents, fires, or community damage that may ensue.