

KP-3216MGC MEGA GREEN

### Features

- 3.2mmx1.6mm SMT LED, 1.1mm THICKNESS.
- LOW POWER CONSUMPTION.
- WIDE VIEWING ANGLE.
- IDEAL FOR BACKLIGHT AND INDICATOR.
- VARIOUS COLORS AND LENS TYPES AVAILABLE.
- PACKAGE : 2000PCS / REEL.

### Description

The Mega Green source color devices are made with DH InGaAlP on GaAs substrate Light Emitting Diode.

### Package Dimensions

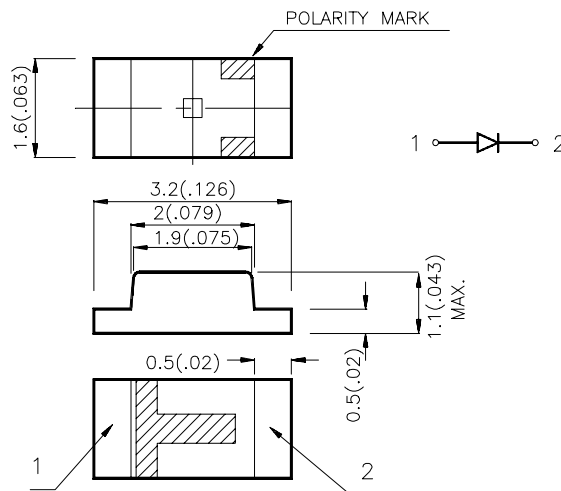

#### Notes:

1. All dimensions are in millimeters (inches).
2. Tolerance is  $\pm 0.2$  (0.0079") unless otherwise noted.
3. Lead spacing is measured where the lead emerge package.
4. Specifications are subject to change without notice.

## Selection Guide

Part No.	Dice	Lens Type	Iv (mcd) @ 20 mA		Viewing Angle
			Min.	Typ.	2θ1/2
KP-3216MGC	MEGA GREEN ( InGaAlP )	WATER CLEAR	20	50	120°

Note:

1. θ1/2 is the angle from optical centerline where the luminous intensity is 1/2 the optical centerline value.

## Electrical / Optical Characteristics at T<sub>A</sub>=25°C

Symbol	Parameter	Device	Typ.	Max.	Units	Test Conditions
$\lambda_{peak}$	Peak Wavelength	Mega Green	574		nm	IF=20mA
$\lambda_D$	Dominant Wavelength	Mega Green	568		nm	IF=20mA
$\Delta\lambda_{1/2}$	Spectral Line Halfwidth	Mega Green	26		nm	IF=20mA
C	Capacitance	Mega Green	20		pF	VF=0V;f=1MHz
V <sub>F</sub>	Forward Voltage	Mega Green	2.1	2.5	V	IF=20mA
I <sub>R</sub>	Reverse Current	Mega Green		10	μA	VR = 5V

## Absolute Maximum Ratings at T<sub>A</sub>=25°C

Parameter	Mega Green	Units
Power dissipation	105	mW
DC Forward Current	30	mA
Peak Forward Current [1]	205	mA
Reverse Voltage	5	V
Operating Temperature	-40°C To +85°C	
Storage Temperature	-40°C To +85°C	

Note:

1. 1/10 Duty Cycle, 0.1ms Pulse Width.

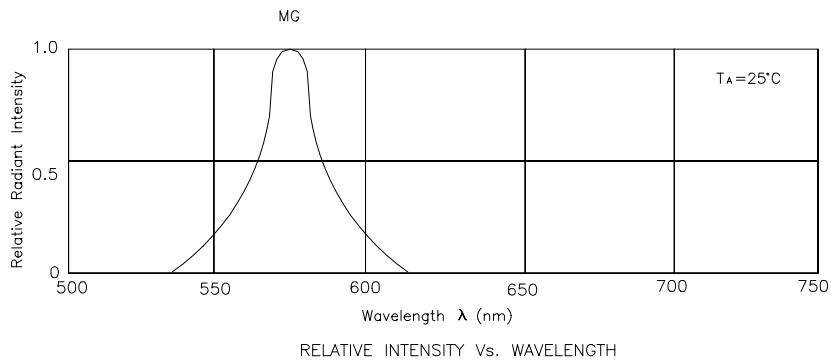

## Mega Green KP-3216MGC

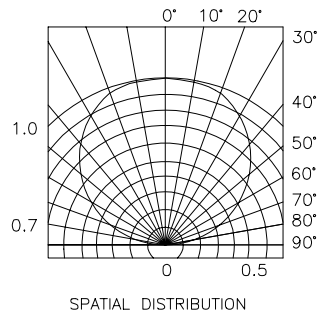
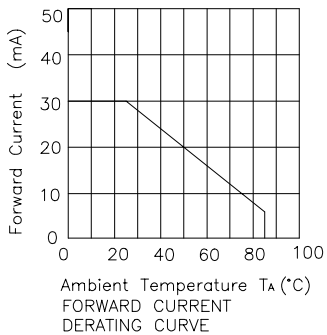
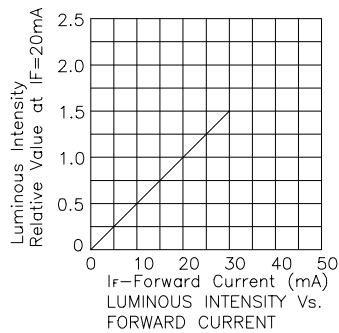
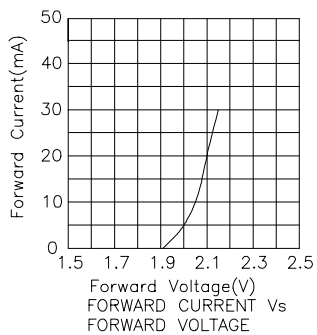

## KP-3216MGC SMT Reflow Soldering Instructions

Number of reflow process shall be less than 2 times and cooling process to normal temperature is required between first and second soldering process.



### Recommended Soldering Pattern (Units : mm)

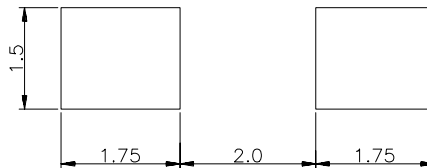

### Tape Specifications (Units : mm)

