

Knob Potentiometer



The P16 is a revolutionary concept in panel mounted potentiometers. This unique design consists of a knob driving and incorporating a cermet potentiometer. Only the mounting hardware and terminals are situated on the back side of the panel reducing to a minimum the required clearance

FEATURES

- 1 Watt at 40°C
- CECC 41300
- **P16** - version for professional and industrial applications
- **PA16** - version for professional audio applications
- Compact (integrated)
- Minimum clearance required
- Safety in use due to good insulation: $> 10^4 \text{ M}\Omega \text{ } 500\text{V}_{\text{DC}}$
- High dielectric strength: $2500\text{V}_{\text{RMS}}$
- Hermetically sealed and panel sealed
- Metallic or plastic knob options
- Cermet or conductive plastic

DIMENSIONS in millimeters

P16 - PA16

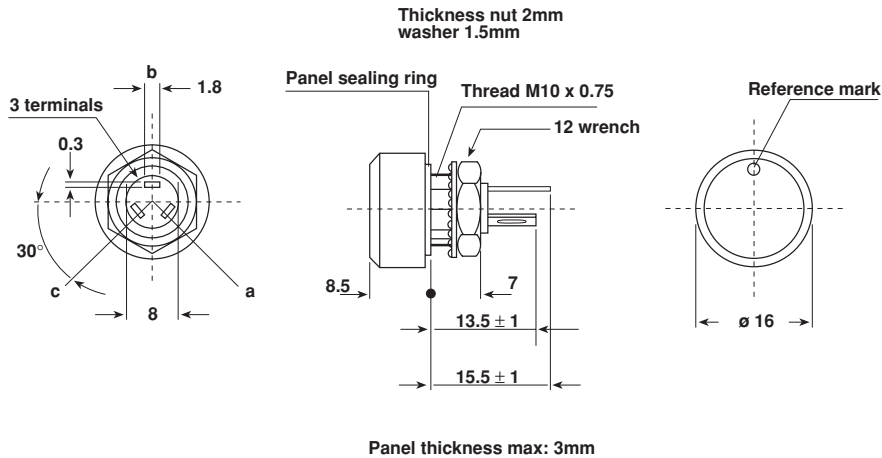

PANEL CUTOUT

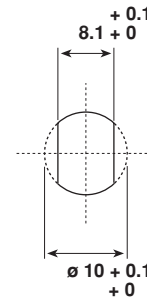

CIRCUIT DIAGRAM

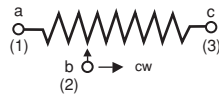



ELECTRICAL SPECIFICATIONS		
Resistive Element		cermet
Electrical Travel		270° ± 10°
Resistance Range	Linear Law	22Ω to 10MΩ
	Logarithmic Laws	100Ω to 2.2MΩ
Standard series E3		1 - 2.2 - 4.7 and on request 1 - 2 - 5
Tolerance	Standard	± 20%
	On Request	± 10%
Power Rating	Linear	1W at + 40°C
	Logarithmic	0.5W at + 40°C
Temperature Coefficient		See Standard Resistance Element Data
Dielectric Strength (RMS)		2500V
Limiting Element Voltage (Linear Law)		350V
Insulation Resistance (500VDC)		≥ 10 ⁴ MΩ
Contact Resistance Variation		3% R _n or 3Ω
End Resistance (Typical)		1Ω
Insulation Resistance (500VDC)		10 ⁶ MΩ

**P16 CHARACTERISTICS
MECHANICAL SPECIFICATIONS**

Mechanical Travel	300° ± 5°
Operating Torque (Ncm)	2 typical
End Stop Torque (max. Ncm)	25
Max Tightening Torque of Mounting Nut (max. Ncm)	250
Unit Weight	4.5 g typical

ENVIRONMENTAL SPECIFICATIONS

	METALLIC KNOB	PLASTIC KNOB
Temperature Range	-55°C to +125°C	-55°C to +85°C
Climatic Category	55 / 100 / 56	55 / 70 / 56
Sealing	sealed container and panel sealed	
Protection Grades	IP67	

POWER RATING CHART

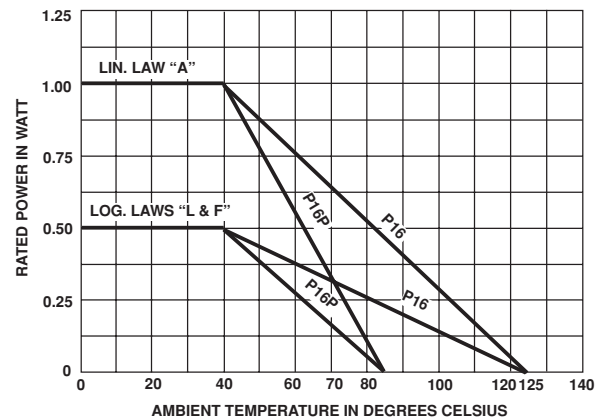

RESISTANCE LAWS

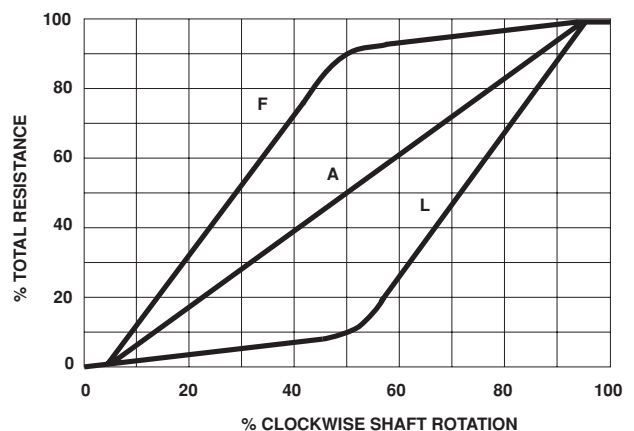



PERFORMANCE		
TESTS	CONDITIONS	TYPICAL VALUES AND DRIFTS
		$\frac{\Delta R_T}{R_T}$ (%)
Load Life	1000 hours Pn 90'/30' at 40°C	± 1% Contact res. variation: < 3% Rn
Climatic Sequence	Phase A dry heat 85°C/125°C Phase B damp heat Phase C cold - 55°C Phase D damp heat 5 cycles	± 0.5% ± 1%
Humidity	56 days	± 0.5% Insulation resistance: > 10 ⁴ MΩ
Temperature Variations	5 cycles - 55°C at + 85°C/125°C	± 0.5%
Shock	50 g at 11 ms 3 successive shocks in 3 directions	± 0.1% ± 0.2%
Vibration	10-55 Hz 0.75mm or 10 g during 6 hours	± 0.1% ± 0.2%
Rotational Life	25000 cycles	± 3% Contact res. variation: < 2% Rn

STANDARD RESISTANCE ELEMENT DATA							
STANDARD RESISTANCE VALUES	LINEAR LAW			LOG LAW			TC. -40°C +85°C
	MAX POWER AT 40°C	MAX WORKING VOLTAGE	MAX CUR. THROUGH ELEMENT	MAX POWER AT 40°C	MAX WORKING VOLTAGE	MAX CUR. THROUGH ELEMENT	
Ω	P1 (W)	Um = $\sqrt{P1XRn}$ 350V _{DC}	Im (mA)	P1 (W)	Um = $\sqrt{P1XRn}$ 350V _{DC}	Im (mA)	10 ⁶ °C
22	1	4.69	213.2				-50
47		6.85	145.8				+200
100		10	100				± 100
220		14.83	67.4				
470		21.67	46.1				
1k		31.62	31.6	0.5	22.4	22.4	
2.2k		46.90	21.32		33.2	15.1	
4.7k		68.55	14.58		48.5	10.3	
10k		100	10		70.7	7.07	
22k		148.32	6.74		105	4.77	
47k		216.7	4.61		153	3.26	
100k	1	316.23	3.16		224	2.24	
220k	0.56	350	1.59	0.5	332	1.51	
470k	0.26	350	0.75	0.26	350	0.74	
1M	0.12	350	0.35	0.12	350	0.35	
2.2M	0.05	350	0.16				
4.7M	0.02	350	0.07				
10M	0.01	350	0.012				

MARKING

- Printed:
- VISHAY trademark
 - ohmic value
 - tolerance (in %)
 - resistance law
 - manufacturing date

CONTROL KNOB

Black metallic knob (N).
Black plastic knob (NP).
For white and blue color see ordering information.
Other dimensions, shapes, colors of control knobs are manufactured on request - please consult VISHAY.
Other reference marks (shapes, colours) and legends can be printed on plastic knob on request - please consult VISHAY.

PACKAGING

Carton box of 20 pieces

PROFESSIONAL AUDIO APPLICATIONS PA16

The industrial cermet track is replaced by a **conductive plastic** track especially selected for its performance characteristics in relation to audio functions.

PA16 SPECIFICATIONS

ELECTRICAL SPECIFICATIONS	
Resistive Element	conductive plastic
Resistance Range PA16	A laws 1kΩ to 1MΩ L,F laws 470Ω to 500kΩ
Tolerance	Standard ± 20% On Request ± 10% (1kΩ to 100kΩ)
Power Rating	0.5W at + 40°C
Temperature Coefficient	± 1000 ppm/°C
Contact Resistance Variation Law A	2% Rn
Limiting Element Voltage	350V



MECHANICAL SPECIFICATIONS

Rotational Life 50000 cycles

ENVIRONMENTAL SPECIFICATIONS

Temperature Range -25°C to +85°C
 Climatic Category 25 / 85 / 56
 Sealing sealed container and panel sealed IP67

PA16 PARTICULAR CHARACTERISTICS				
NOMINAL RESISTANCE	LAWS A, L, F			T.C. -25°C +100°C
	MAX. DISSIPATION AT 40°C	MAX. VOLTAGE	MAX. CUR. THROUGH THE WIPER	
Ω	W	V	mA	ppm/°C
1k	0.5	22.4	22.4	± 1000
2.2k	↓	33.2	15.1	
4.7k		48.5	10.3	
10k		79.7	7.07	
22k		105	4.77	
47k	153	3.26		
100k	↓	224	2.24	
220k	0.5	332	1.51	
470k	0.26	350	0.74	

PERFORMANCE		
TESTS	CONDITIONS	TYPICAL VALUES AND DRIFTS
		$\frac{\Delta R_{ac}}{R_{ac}}$ (%) $\frac{\Delta R_{ac}}{R_{ac}}$ (%)
Load Life	1000 hours at Pn 90°/30° cycle at +40°C	± 5% Insulation resistance: > 10 ⁴ MW Contact res. variatio: < 2% Rn
Long Term Damp Heat	56 days	± 2% ± 1% Insulation resistance: > 10 ⁴ MΩ
Shock	50 g at 11 ms 3 successive shocks in 3 axes	± 0.2% ± 0.5%
Vibration	10-55 Hz 0.75mm or 10 g during 6 hours	± 0.2% $\frac{\Delta V_{ab}}{V_{ac}}$ ≤ ± 0.5%
Rotational Life	50000 cycles	± 5% Contact res. variation: < 2% Rn

ORDERING INFORMATION					
PA, PA16	NP	22 kΩ	20%	A	BO20
SERIES	CONTROL KNOB DESIGNATION	OHMIC VALUE	TOLERANCE	LAW	PACKAGING
	N : metallic black color NP : plastic black color W : metallic white color WP : plastic white color BP : plastic blue color			A : linear L : clockwise logarithmic F : inverse clockwise logarithmic	

SAP PART NUMBERING GUIDELINES																	
P	1	6	N	P	2	2	3	M	B	1	5						
MODEL		STYLE		OHMIC VALUE			TOL	PACKAGING CODE			SPECIAL (IF APPLICABLE)						
See the end of this data book for conversion tables																	



Notice

Specifications of the products displayed herein are subject to change without notice. Vishay Intertechnology, Inc., or anyone on its behalf, assumes no responsibility or liability for any errors or inaccuracies.

Information contained herein is intended to provide a product description only. No license, express or implied, by estoppel or otherwise, to any intellectual property rights is granted by this document. Except as provided in Vishay's terms and conditions of sale for such products, Vishay assumes no liability whatsoever, and disclaims any express or implied warranty, relating to sale and/or use of Vishay products including liability or warranties relating to fitness for a particular purpose, merchantability, or infringement of any patent, copyright, or other intellectual property right.

The products shown herein are not designed for use in medical, life-saving, or life-sustaining applications. Customers using or selling these products for use in such applications do so at their own risk and agree to fully indemnify Vishay for any damages resulting from such improper use or sale.