



ALL RIGHTS RESERVED. NO PORTION OF THIS PUBLICATION, WHETHER IN WHOLE OR IN PART CAN BE REPRODUCED WITHOUT THE EXPRESS WRITTEN CONSENT OF SPC TECHNOLOGY.

SPC-F005.DWG

REVISIONS

DOC. NO. SPC-F005 * Effective: 7/8/02 * DCP No: 1398

DCP #	REV	DESCRIPTION	DRAWN	DATE	CHECKD	DATE	APPRVD	DATE
1789	A	RELEASED	DCM	1/15/07	TUL	1/15/07	JWM	1/15/07

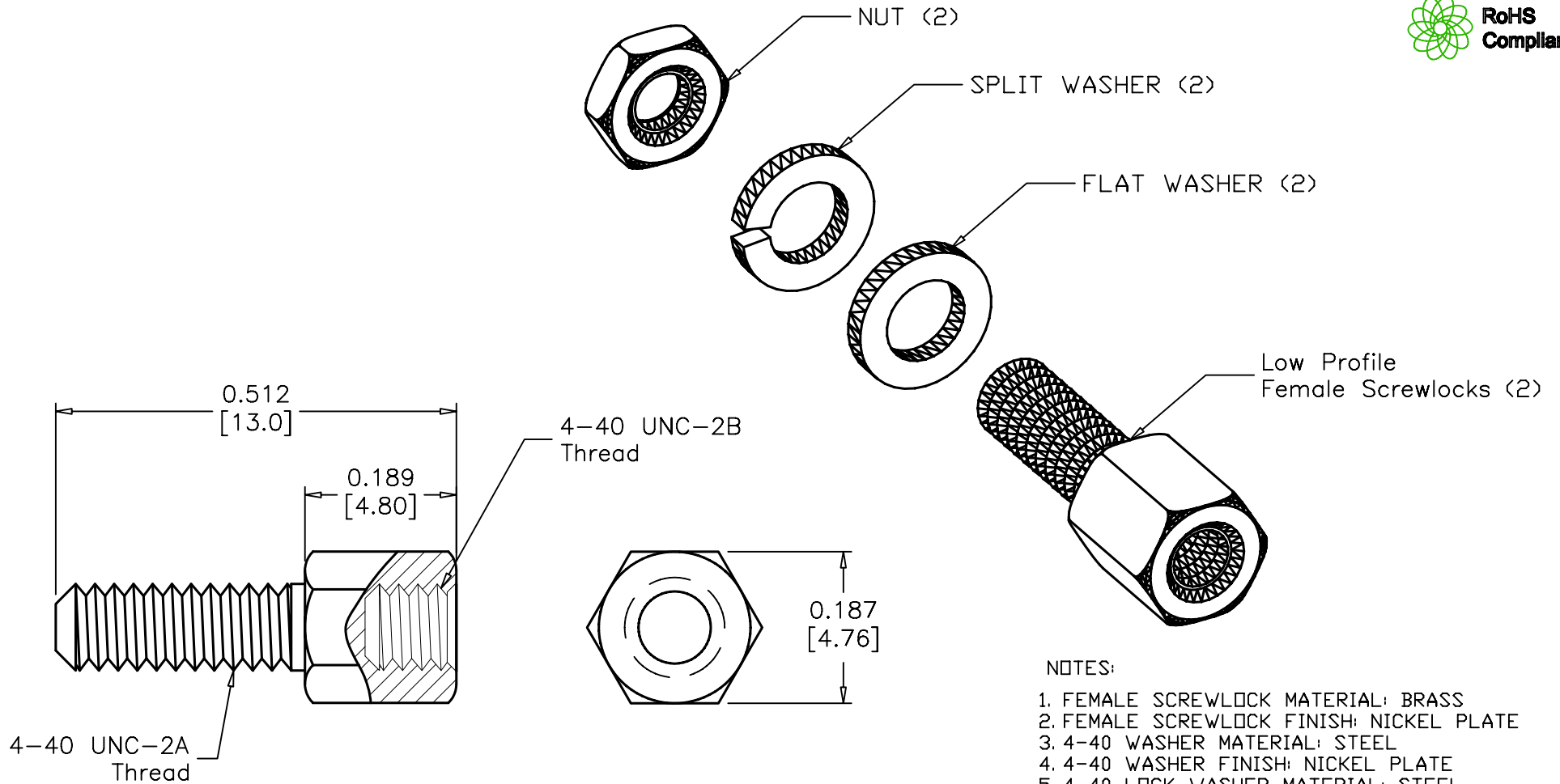

NOTES:

1. FEMALE SCREWLOCK MATERIAL: BRASS
2. FEMALE SCREWLOCK FINISH: NICKEL PLATE
3. 4-40 WASHER MATERIAL: STEEL
4. 4-40 WASHER FINISH: NICKEL PLATE
5. 4-40 LOCK WASHER MATERIAL: STEEL
6. 4-40 LOCK WASHER FINISH: NICKEL PLATE
7. 4-40 NUT MATERIAL: STEEL
8. 4-40 NUT FINISH: NICKEL PLATE

DISCLAIMER:
ALL STATEMENTS AND TECHNICAL INFORMATION CONTAINED HEREIN ARE BASED UPON INFORMATION AND/OR TESTS WE BELIEVE TO BE ACCURATE AND RELIABLE. SINCE CONDITIONS OF USE ARE BEYOND OUR CONTROL, THE USER SHALL DETERMINE THE SUITABILITY OF THE PRODUCT FOR THE INTENDED USE AND ASSUME ALL RISK AND LIABILITY WHATSOEVER IN CONNECTION THEREWITH.

TOLERANCES:
UNLESS OTHERWISE SPECIFIED, DIMENSIONS ARE FOR REFERENCE PURPOSES ONLY.

DRAWN BY:	DATE:
Dan mcVicker	1/15/07
CHECKED BY:	DATE:
Tom Lee	1/15/07
APPROVED BY:	DATE:
Jeff McVicker	1/15/07

DRAWING TITLE: Female Screwlock Set			
SIZE	DWG. NO.	ELECTRONIC FILE	REV
A	SPC15082	80K5431.dwg	A
SCALE: NTS		U.O.M.: INCHES [mm]	SHEET: 1 OF 1