

Curvette R/RSC-Series Single Pole Rocker and Paddle Switches



Since its introduction, the Curvette switch has become the barometer for versatility and performance in the miniature switch market. Self cleaning contacts, International approvals, along with a wide variety of circuits, ratings, and actuator options makes the Curvette the switch of choice for many markets including Appliance, HVAC, Office Lighting, Transportation, Commercial Food and Lawn and Garden.

Dielectric Strength
 UL/CSA:1000V - live to dead metal
 VDE: 4000V - live to dead metal;
 750V - across open contacts
Electrical Life
 100,000 cycles
Mechanical Life
 100,000 cycles
Operating Temperature
 32°F to 185°F (0°C to 85°C)

R/RSC-Series Dimensional Specifications: in.[mm]

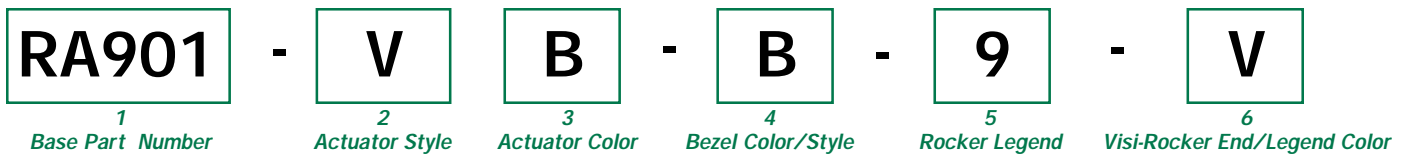
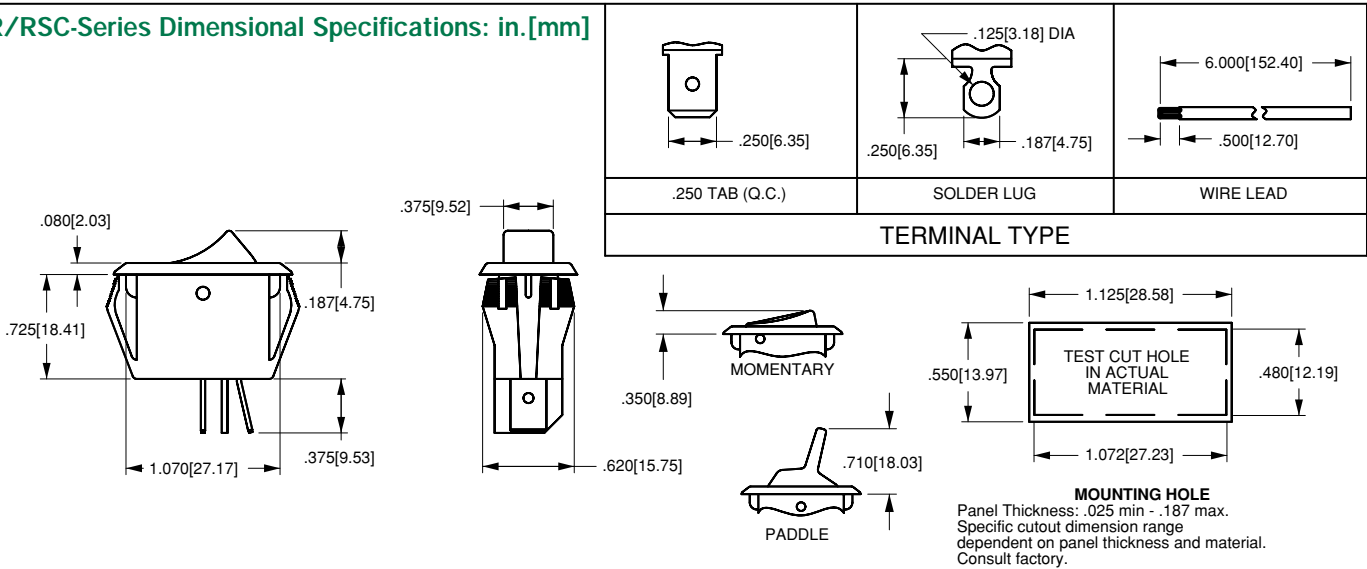

1 BASE PART NUMBER: SERIES/CIRCUITRY/RATING¹/TERMINATION

10A 250 VAC; 16A 125 VAC; 3/4 HP 125-250 VAC; 10(4) A 250 VACu T85	Solder Lugs	.250 Tabs	Wire Leads
OFF-NONE-ON	RA900	RA901	RA905
ON-NONE-ON	RB900	RB901	RB905
ON-OFF-ON ³	RC910	RC911	RC915
OFF-NONE-(ON) ²	RD220	RD221	RD225
15A 250 VAC; 20A 125 VAC; 3/4 HP 125-250 VAC	Solder Lugs	.250 Tabs	
OFF-NONE-ON	RSCA200	RSCA201	
ON-NONE-ON	RSCB200	RSCB201	

6 VISI-ROCKER END/LEGEND COLOR

N	n/a
B	black
V	Visi-red
W	white

2 ACTUATOR STYLE

M	momentary rocker
P	paddle
R	rocker
V	Visi-rocker (2 color)

4 BEZEL COLOR/STYLE

B	black - standard		1	black - oval
W	white - standard		2	white - oval

3 ACTUATOR COLOR

B	black
W	white

5 ROCKER LEGEND

none	0	0
OFF-ON vertical	1	A
OFF-ON horizontal	2	B
O-I horizontal	8	D
O-I vertical	9	F
dual OFF-ON I-O		H

NOTES
 PC Terminals also available, consult factory for details.
 1 For additional ratings, consult factory.
 2 Rating is 8A 250 VAC, 12A 125 VAC, 1/2 HP 125-250 VAC, and must specify M actuator style.
 3 Not rated at 3/4 HP 125-250 VAC
 () indicates momentary function.