

Customer Information Sheet

DRAWING No.: M80-828XXXX

SHEET 2 OF 2

IF IN DOUBT - ASK

Ⓒ

NOT TO SCALE

THIRD ANGLE PROJECTION

ALL DIMENSIONS IN mm

ORDER CODE:

M80-828XXXX

TOTAL No. OF WAYS

04, 06, 08, 10, 12
14, 16, 18, 20, 26
34, 44

FINISH

06 - TIN/LEAD
22 - SELECTIVE GOLD
+ TIN/LEAD
42 - SELECTIVE GOLD
+ 100% TIN
45 - GOLD
46 - 100% TIN

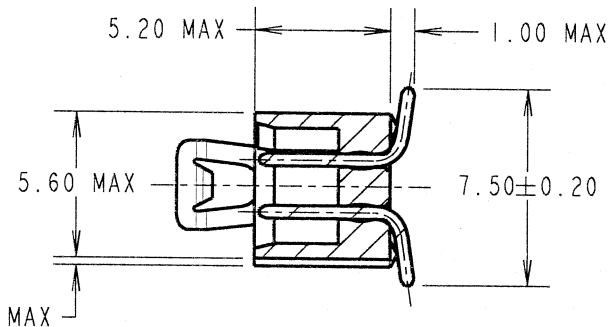
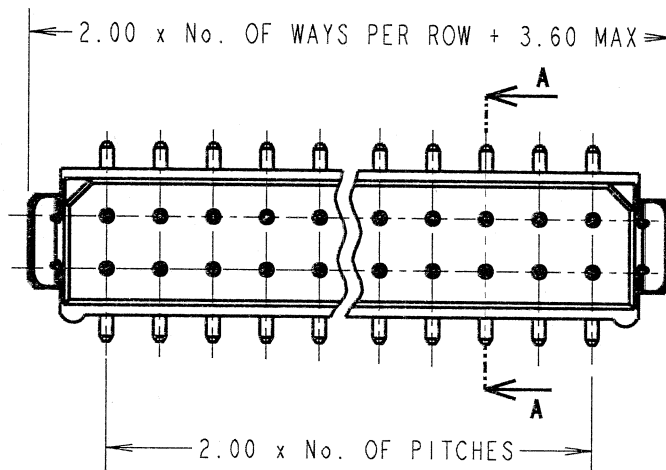

SECTION A-A

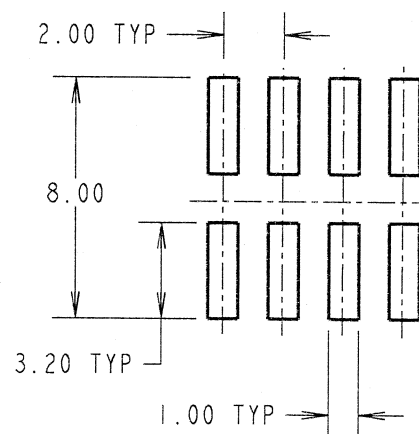
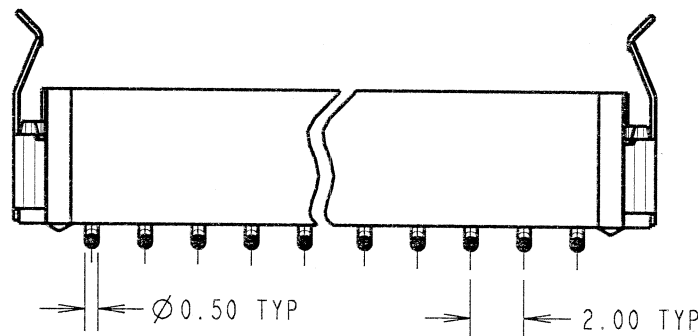

RECOMMENDED
PCB LAYOUT

SPECIFICATIONS:

MATERIAL:
MOULDING = POLYAMIDE 46 UL94V-0, BLACK
CONTACTS = PHOSPHOR BRONZE
LATCHES = BERYLLIUM COPPER

FINISH:
CONTACTS:
06 = 3.0µ 90/10 TIN/LEAD ALL OVER
22 = 0.75µ GOLD ON CONTACT AREA,
3.0µ 90/10 TIN/LEAD ON TAILS
42 = 0.75µ GOLD ON CONTACT AREA,
3.0µ 100% TIN ON TAILS
45 = 0.75µ GOLD ALL OVER
46 = 3.0µ 100% TIN ALL OVER
LATCH = 1.25µ NICKEL

ELECTRICAL:
CURRENT RATING AT 25°C = 3.0A MAX
CURRENT RATING AT 85°C = 2.2A MAX
WORKING VOLTAGE = 120V AC/DC
VOLTAGE PROOF = 360V AC/DC
CONTACT RESISTANCE (INITIAL) = 20 mΩ MAX
CONTACT RESISTANCE (AFTER CONDITIONING) = 25 mΩ MAX
INSULATION RESISTANCE (INITIAL) = 1,000 MΩ MIN
INSULATION RESISTANCE (AFTER CONDITIONING) = 100 MΩ MIN

MECHANICAL:
DURABILITY = 500 OPERATIONS
ENVIRONMENTAL:
TEMPERATURE RANGE = -55°C TO +125°C
PACKING:
TUBE
FOR COMPLETE SPECIFICATION, SEE COMPONENT
SPECIFICATION C005XX (LATEST ISSUE)

JMB	7	26.10.05	8807
NAME	ISS.	DATE	C/NOTE
APPROVED: <i>[Signature]</i>			
CHECKED: <i>[Signature]</i>			
DRAWN: I. SANDY		CUSTOMER REF.:	
ASSEMBLY DRG:			

HARWIN

THIS DRAWING AND ANY INFORMATION OR DESCRIPTIVE MATTER SET OUT HEREON ARE CONFIDENTIAL AND COPYRIGHT PROPERTY OF THE HARWIN GROUP AND MUST NOT BE DISCLOSED, LOANED, COPIED OR USED FOR MANUFACTURING, TENDERING OR FOR ANY OTHER PURPOSE WITHOUT THEIR WRITTEN PERMISSION.

TOLERANCES
X. = ±1mm
X.X = ±0.25mm
X.XX = ±0.10mm
X.XXX = ±0.01mm

ANGLES = ±5°
UNLESS STATED

MATERIAL:
SEE ABOVE

FINISH: SEE ABOVE

S/AREA: mm²

TITLE: DATAMATE DIL
VERTICAL SMT PLUG
ASSEMBLY - LATCHED

DRAWING NUMBER:
M80-828XXXX

SHT
2
OF
2

HARWIN INC U.S.A. TEL: (812) 542 2540 FAX: (812) 542 2541	HARWIN PLC U.K. TEL: 023 9231 4545 FAX: 023 9231 4590	HARWIN PTE SINGAPORE TEL: 65 6779 4909 FAX: 65 6779 3868
---	---	--