

THIS DRAWING IS UNPUBLISHED. RELEASED FOR PUBLICATION AUGUST, 2005.
 © COPYRIGHT 2005 BY TYCO ELECTRONICS CORPORATION. ALL RIGHTS RESERVED.

| LOC | DIST | REVISIONS | | | | | |
|-----|------|-----------|-----|---------------|---------|-----|------|
| | | P | LTR | DESCRIPTION | DATE | DWN | APVD |
| E | B | B | | ECR-05-006587 | 09AUG05 | JMS | FWK |

- NOTES:
- 1. SINGLE PACK IN ACCORDANCE WITH AMP SPEC 107-3275
 - 2. 50 TRAY PACK IN ACCORDANCE WITH AMP SPEC 107-3275
 - 3. Au PLATING OVER Ni PLATING OVER Cu PLATING
 - 4. Ni PLATING OVER Cu PLATING
 - 5. TIN PLATING
 - 6. RECOMMENDED SELF-TAPPING SCREW 221108-4
 - 7. RECOMMENDED MOUNT NUT 1-1634816-0
 - 8. RECOMMENDED LOCKWASHER 1-1634817-0
 - 9. CHARACTERISTICS

| | |
|-------------------------------|------------|
| FREQUENCY RANGE: | DC-2GHz |
| NOMINAL IMPEDANCE: | 75 OHMS |
| WORKING VOLTAGE: | 500V RMS |
| INSULATION RESISTANCE: | 5000 MOHMS |
| DIELECTRIC WITHSTAND VOLTAGE: | 1500V RMS |
| CONTACT RESISTANCE: | |
| CENTRE CONTACT: | 1.5 mOHMS |
| OUTER CONTACT: | 0.2 mOHMS |
 - 10. MECHANICAL CHARACTERISTICS

| | |
|-------------|-----------|
| DURABILITY: | 50 CYCLES |
|-------------|-----------|
 - 11. FOR TECHNICAL DATA REFER TO YOUR LOCAL TYCO ELECTRONICS SALES OFFICE
 - 12. ALL DIMENSIONS ARE NOMINAL FOR REFERENCE ONLY UNLESS OTHERWISE STATED

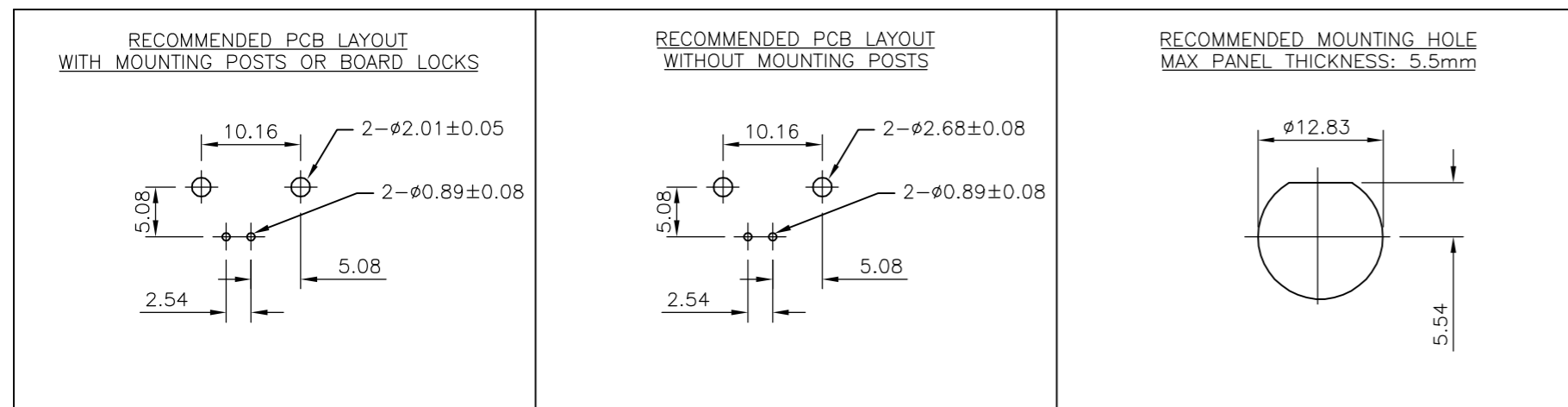
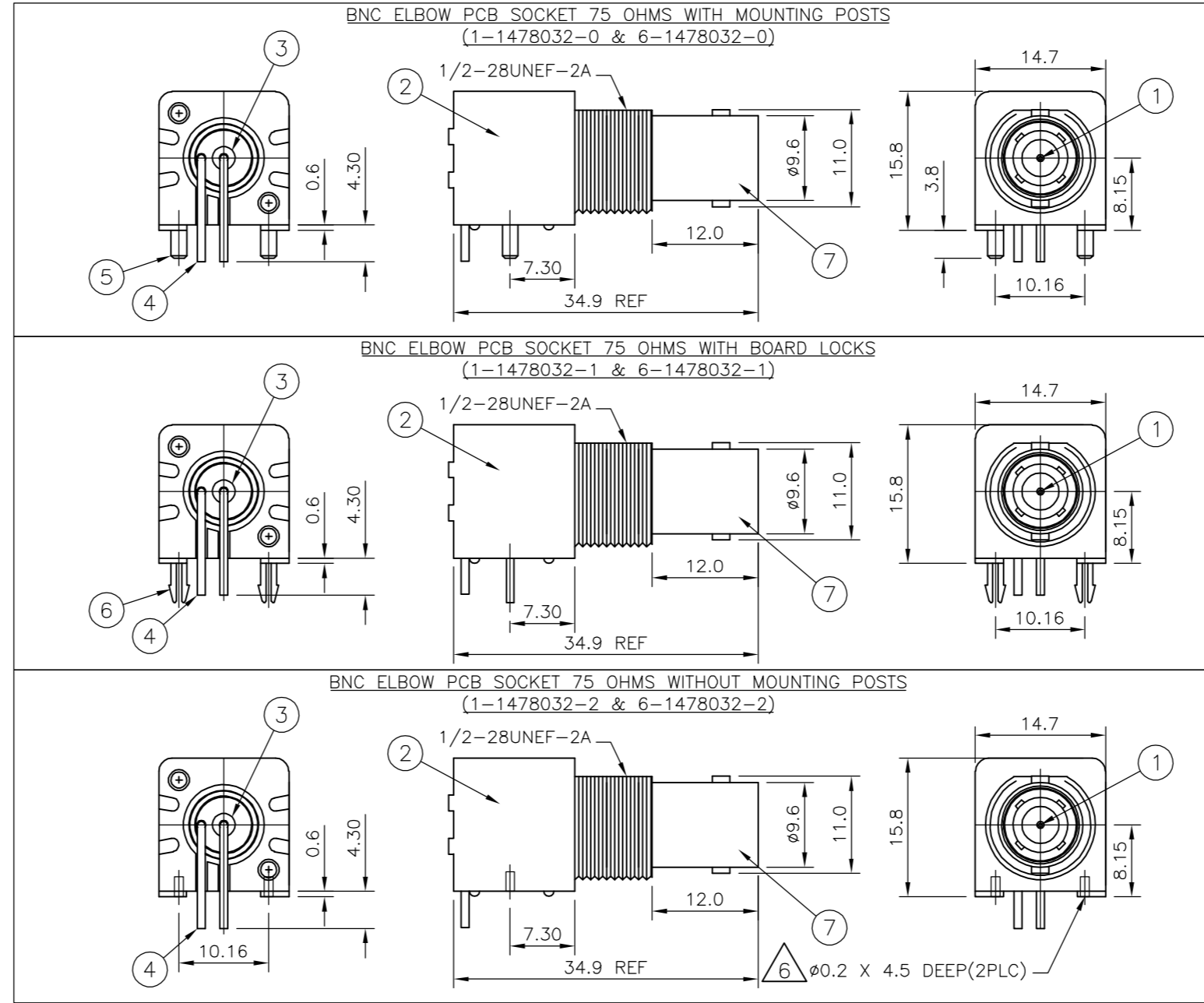

| QTY | DESCRIPTION | MATERIAL | ITEM | | | |
|------|-------------|----------|------|--------------|---------------|---|
| 1 | 1 | 1 | 1 | ZINC DIECAST | BOARD LOCK | 7 |
| - | - | 2 | - | BRASS | BOARD LOCK | 6 |
| - | - | - | 2 | BRASS | MOUNTING POST | 5 |
| 1 | 1 | 1 | 1 | BRASS | SOLDER TAIL | 4 |
| 1 | 1 | 1 | 1 | PE-606 | INSULATOR | 3 |
| 1 | 1 | 1 | 1 | PBT WHITE | HOUSING | 2 |
| 1 | 1 | 1 | 1 | BRASS | CONTACT | 1 |
| 6--2 | 1--2 | 6--1 | 1--1 | 6--0 | 1--0 | |
| △ | △ | △ | △ | △ | △ | |

| | | | | | | | |
|--|--|------------------|----------------|------------------------------|------|------------------------------|--|
| THIS DRAWING IS A CONTROLLED DOCUMENT. | | DWN | J.SANDWELL | 09AUG05 | | Tyco Electronics Corporation | |
| DIMENSIONS: mm | | CHK | S.PARLOW | 09AUG05 | | Bideford, UK, EX39 4HE | |
| TOLERANCES UNLESS OTHERWISE SPECIFIED | | APVD | F.WHEELER-KING | 09AUG05 | NAME | | |
| 0 PLC ± | | PRODUCT SPEC | | BNC R/A INSULATED PCB SOCKET | | | |
| 1 PLC ± | | APPLICATION SPEC | | 75 OHM WHITE | | | |
| 2 PLC ± | | WEIGHT | | - | | | |
| 3 PLC ± | | SCALE | | A2 | | | |
| 4 PLC ± | | CAGE CODE | | 00779 | | | |
| ANGLES ± | | DRAWING NO | | C=1478032 | | | |
| FINISH | | RESTRICTED TO | | - | | | |
| SEE TABLE | | CUSTOMER DRAWING | | SCALE NTS SHEET 1 OF 1 REV B | | | |

1478032