

713 5701

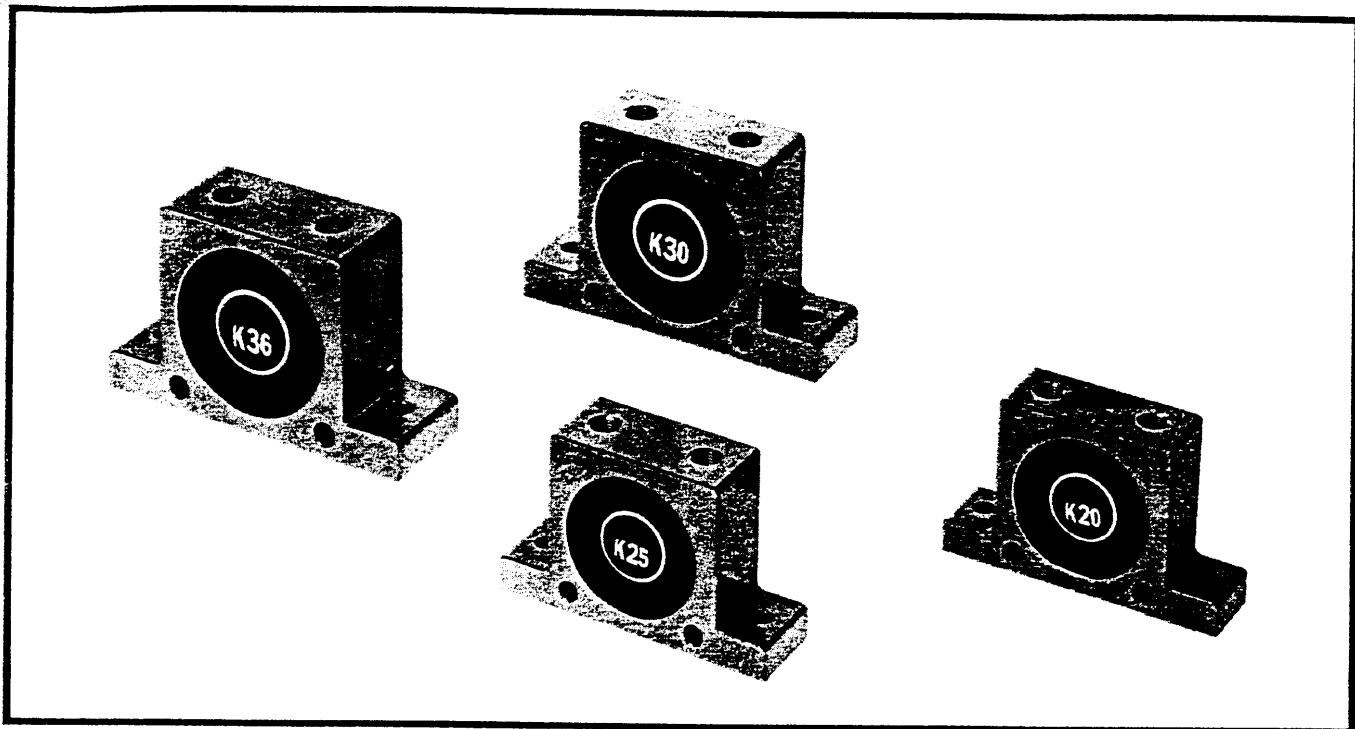

Description

Manufactured with a rustproof extruded aluminium body fitted with hardened steel races on which a steel ball rotates.

Nylon end plates are located on either side to contain the ball and prevent the ingress of dust and water, thus allowing the unit to be used in dusty or wet environments. Inlet and exhaust ports have standard pipe threads, allowing the exhaust air to be piped away. Suitable for temperatures up to 212°F. Four mounting holes are provided, two vertically and two horizontally.

Note: For temperatures above 212°F special K-20 to K-36 units are available with aluminium end plates.

Application

-Series K, which is small in overall size, pneumatic ball vibrators frequency can be regulated by adjusting the flow of air to the vibrator making them useful for:

- * Assisting the flow of material from chutes and hoppers
- * Preventing bottles and similar objects from locking together and blocking conveyor systems
- * Compaction of material in containers or moulds
- * Separation of various sizes of material on screens.

PNEUMATIC BALL VIBRATORS

Type K

VIBRATECHNIQUES LTD

2 CHAPEL ROAD

BRIGHTON BN41 1PF

TELEPHONE: 01273 430977

FAX: 01273 430978

VIBTEC

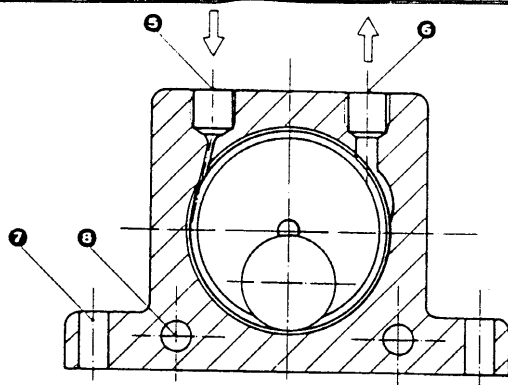

- 1. Extruded aluminium alloy body
- 2. Hardened ground steel alloy races
- 3. Nylon endplates
- 4. Hardened lapped ball
- 5. Air inlet
- 6. Air exhaust
- 7. Base mounting holes
- 8. Lateral mounting

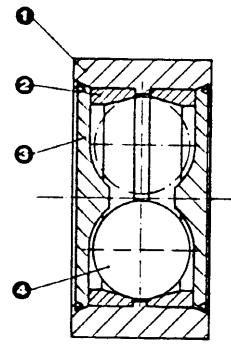

K-8 to K-36

Standard Units
with Nylon endplates
Maximum Temperature 100°C = 212°

K-20HT to K-36 HT

Special Units
with Aluminium endplates
Maximum Temperature 150°C = 300°F

PERFORMANCE DATA

Type	Frequency V.P.M.			Centrifugal force						Air consumption/Minute								
	2 Bar	29 PSI	4 Bar	58 PSI	6 Bar	87 PSI	2Bar	29PSI	4Bar	58PSI	6Bar	87PSI	2Bar	29PSI	4Bar	58PSI	6Bar	87PSI
	Bar	PSI	Bar	PSI	Bar	PSI	N	LBS	N	LBS	N	LBS	Litr	CF	Litr	CF	Litr	CF
K- 8	24,500	31,000	35,000	180	40	290	52	370	83	83	2.9	145	5.1	195	6.9			
K-10	21,600	26,800	30,000	210	47	320	72	400	90	92	3.2	150	5.3	200	7.1			
K-13	16,000	20,800	23,600	390	88	650	146	850	191	94	3.3	158	5.6	225	7.9			
K-16	14,300	17,600	20,200	540	122	820	184	1,090	245	122	4.3	200	7.1	280	9.9			
K-20	10,700	14,200	16,000	760	171	1,340	302	1,700	382	130	4.6	230	8.1	340	12.0			
K-25	10,100	13,200	14,500	1,180	265	2,000	450	2,420	545	160	5.6	290	10.2	425	15.0			
K-30	7,600	10,000	11,000	1,530	344	2,660	598	3,210	722	215	7.6	375	13.2	570	20.0			
K-36	7,500	9,300	10,300	2,340	526	3,590	808	4,400	990	260	9.2	475	16.8	675	24.0			

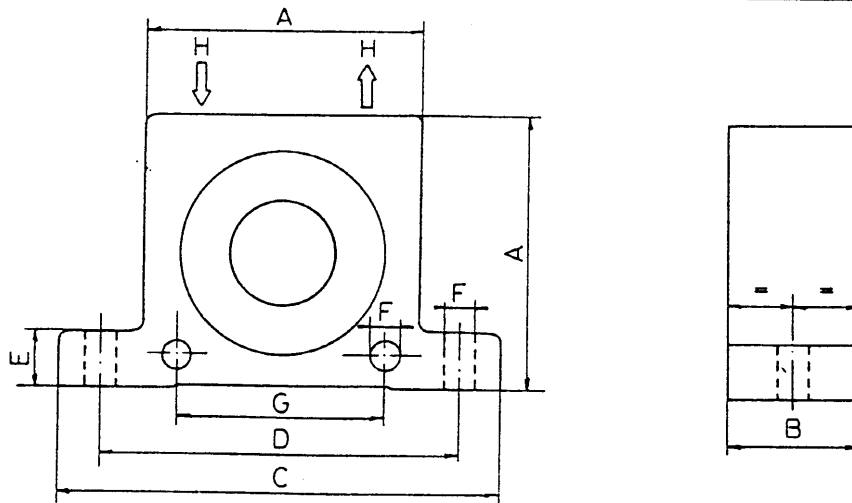

DIMENSIONS

Type	A		B		C		D		E		F		G		H Thread BSP	Weight	
	mm	inch	mm	inch	mm	inch	mm	inch	mm	inch	mm	inch	mm	inch		kg	Lbs
K- 8	50	1.97	20	0.79	86	3.38	68	2.68	12	0.47	7	0.27	40	1.57	1/4"	.130	.29
K-10	50	1.97	20	0.79	86	3.38	68	2.68	12	0.47	7	0.27	40	1.57	1/4"	.130	.29
K-13	65	2.56	24	0.94	113	4.45	90	3.54	16	0.63	9	0.35	50	1.97	1/4"	.260	.57
K-16	65	2.56	27	1.06	113	4.45	90	3.54	16	0.63	9	0.35	50	1.97	1/4"	.300	.66
K-20	80	3.15	33	1.30	128	5.04	104	4.09	16	0.63	9	0.35	60	2.36	1/4"	.530	1.17
K-25	80	3.15	38	1.50	128	5.04	104	4.09	16	0.63	9	0.35	60	2.36	1/4"	.630	1.39
K-30	100	3.94	44	1.73	160	6.30	130	5.12	20	0.79	11	0.43	80	3.15	3/8"	1.130	2.49
K-36	100	3.94	50	1.97	160	6.30	130	5.12	20	0.79	11	0.43	80	3.15	3/8"	1.340	2.95

Data obtained on a heavy laboratory test block. Frequency and force will decrease on a less rigid mount. We reserve the right to improve, modify or withdraw specifications or products without notice or obligation.