

P-Channel JFETs

J174 SST174
J175 SST175
J176 SST176
J177 SST177

Product Summary

Part Number	V _{GS(off)} (V)	r _{DS(on)} Max (Ω)	I _{D(off)} Typ (pA)	t _{ON} Typ (ns)
J/SST174	5 to 10	85	-10	25
J/SST175	3 to 6	125	-10	25
J/SST176	1 to 4	250	-10	25
J/SST177	0.8 to 2.25	300	-10	25

Features

- Low On-Resistance: J174 <85 Ω
- Fast Switching—t_{ON}: 25 ns
- Low Leakage: -10 pA
- Low Capacitance: 5 pF
- Low Insertion Loss

Benefits

- Low Error Voltage
- High-Speed Analog Circuit Performance
- Negligible “Off-Error,” Excellent Accuracy
- Good Frequency Response
- Eliminates Additional Buffering

Applications

- Analog Switches
- Choppers
- Sample-and-Hold
- Normally “On” Switches
- Current Limiters

Description

The J/SST174 series consists of p-channel analog switches designed to provide low on-resistance and fast switching. This series simplifies series-shunt switching applications when combined with the Siliconix J/SST111 series.

The TO-226AA (TO-92) plastic package provides a low-cost option, while the TO-236 (SOT-23) package provides surface-mount capability. Both the J and SST series are available in tape-and-reel for automated assembly (see Packaging Information).

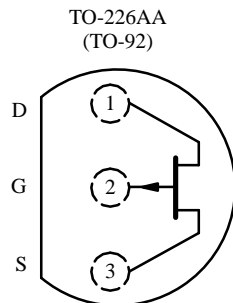

Top View
 J174
 J175
 J176
 J177

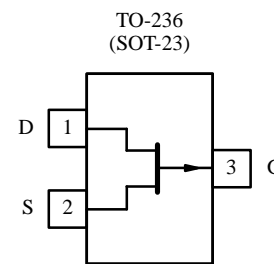

Top View
 SST174 (S4)*
 SST175 (S5)*
 SST176 (S6)*
 SST177 (S7)*

*Marking Code for TO-236

Updates to this data sheet may be obtained via facsimile by calling Siliconix FaxBack, 1-408-970-5600. Please request FaxBack document #70257. Applications information may also be obtained via FaxBack, request document #70597.

Absolute Maximum Ratings

Gate-Drain Voltage	30 V	Lead Temperature ($1/16''$ from case for 10 sec.)	300°C
Gate-Source Voltage	30 V	Power Dissipation ^a	350 mW
Gate Current	-50 mA		
Storage Temperature	-55 to 150°C	Notes	
Operating Junction Temperature	-55 to 150°C	a. Derate 2.8 mW/°C above 25°C	

Specifications^a for J/SST174 and J/SST175

Parameter	Symbol	Test Conditions	Typ ^b	Limits				Unit
				J/SST174		J/SST175		
				Min	Max	Min	Max	
Static								
Gate-Source Breakdown Voltage	$V_{(BR)GSS}$	$I_G = 1 \mu A, V_{DS} = 0 V$	45	30		30		V
Gate-Source Cutoff Voltage	$V_{GS(off)}$	$V_{DS} = -15 V, I_D = -10 nA$		5	10	3	6	
Saturation Drain Current ^c	I_{DSS}	$V_{DS} = -15 V, V_{GS} = 0 V$		-20	-135	-7	-70	mA
Gate Reverse Current	I_{GSS}	$V_{GS} = 20 V, V_{DS} = 0 V$ $T_A = 125^\circ C$	0.01		1		1	nA
			5					
Gate Operating Current	I_G	$V_{DG} = -15 V, I_D = -1 mA$	0.01					nA
Drain Cutoff Current	$I_{D(off)}$	$V_{DS} = -15 V, V_{GS} = 10 V$ $T_A = 125^\circ C$	-0.01		-1		-1	nA
			-5					
Drain-Source On-Resistance	$r_{DS(on)}$	$V_{GS} = 0 V, V_{DS} = -0.1 V$			85		125	Ω
Gate-Source Forward Voltage	$V_{GS(F)}$	$I_G = -1 mA, V_{DS} = 0 V$	-0.7					V
Dynamic								
Common-Source Forward Transconductance	g_{fs}	$V_{DS} = -15 V, I_D = -1 mA$ $f = 1 kHz$	4.5					mS
Common-Source Output Conductance	g_{os}		20					μS
Drain-Source On-Resistance	$r_{ds(on)}$	$V_{GS} = 0 V, I_D = 0 mA, f = 1 kHz$			85		125	Ω
Common-Source Input Capacitance	C_{iss}	$V_{DS} = 0 V, V_{GS} = 0 V, f = 1 MHz$	20					pF
Common-Source Reverse Transfer Capacitance	C_{rss}	$V_{DS} = 0 V, V_{GS} = 10 V$ $f = 1 MHz$	5					
Equivalent Input Noise Voltage	\bar{e}_n	$V_{DG} = -10 V, I_D = -1 mA$ $f = 1 kHz$	20					nV/\sqrt{Hz}
Switching								
Turn-On Time	$t_{d(on)}$	$V_{GS(L)} = 0 V, V_{GS(H)} = 10 V$ See Switching Circuit	10					ns
	t_r		15					
Turn-Off Time	$t_{d(off)}$		10					
	t_f		20					

Notes

- a. $T_A = 25^\circ C$ unless otherwise noted.
- b. Typical values are for DESIGN AID ONLY, not guaranteed nor subject to production testing.
- c. Pulse test: $PW \leq 300 \mu s$ duty cycle $\leq 3\%$.

PSCIA

Specifications^a for J/SST176 and J/SST177

Parameter	Symbol	Test Conditions	Typ ^b	Limits				Unit
				J/SST176		J/SST177		
				Min	Max	Min	Max	
Static								
Gate-Source Breakdown Voltage	$V_{(BR)GSS}$	$I_G = 1 \mu A, V_{DS} = 0 V$	45	30		30		V
Gate-Source Cutoff Voltage	$V_{GS(off)}$	$V_{DS} = -15 V, I_D = -10 nA$		1	4	0.8	2.25	V
Saturation Drain Current ^c	I_{DSS}	$V_{DS} = -15 V, V_{GS} = 0 V$		-2	-35	-1.5	-20	mA
Gate Reverse Current	I_{GSS}	$V_{GS} = 20 V, V_{DS} = 0 V$	0.01		1		1	nA
		$T_A = 125^\circ C$	5					
Gate Operating Current	I_G	$V_{DG} = -15 V, I_D = -1 mA$	0.01					nA
Drain Cutoff Current	$I_{D(off)}$	$V_{DS} = -15 V, V_{GS} = 10 V$	-0.01		-1		-1	nA
		$T_A = 125^\circ C$	-5					
Drain-Source On-Resistance	$r_{DS(on)}$	$V_{GS} = 0 V, V_{DS} = -0.1 V$			250		300	Ω
Gate-Source Forward Voltage	$V_{GS(F)}$	$I_G = -1 mA, V_{DS} = 0 V$	-0.7					V
Dynamic								
Common-Source Forward Transconductance	g_{fs}	$V_{DS} = -15 V, I_D = -1 mA$ $f = 1 kHz$	4.5					mS
	g_{os}		20					μS
Drain-Source On-Resistance	$r_{ds(on)}$	$V_{GS} = 0 V, I_D = 0 mA, f = 1 kHz$			250		300	Ω
Common-Source Input Capacitance	C_{iss}	$V_{DS} = 0 V, V_{GS} = 0 V, f = 1 MHz$	20					pF
Common-Source Reverse Transfer Capacitance	C_{rss}	$V_{DS} = 0 V, V_{GS} = 10 V$ $f = 1 MHz$	5					
Equivalent Input Noise Voltage	\bar{e}_n	$V_{DG} = -10 V, I_D = -1 mA$ $f = 1 kHz$	20					nV/\sqrt{Hz}
Switching								
Turn-On Time	$t_{d(on)}$	$V_{GS(L)} = 0 V, V_{GS(H)} = 10 V$ See Switching Circuit	10					ns
	t_r		15					
Turn-Off Time	$t_{d(off)}$		10					
	t_f		20					

Notes

- $T_A = 25^\circ C$ unless otherwise noted.
- Typical values are for DESIGN AID ONLY, not guaranteed nor subject to production testing.
- Pulse test: $PW \leq 300 \mu s$ duty cycle $\leq 3\%$.

PSCIA

Typical Characteristics

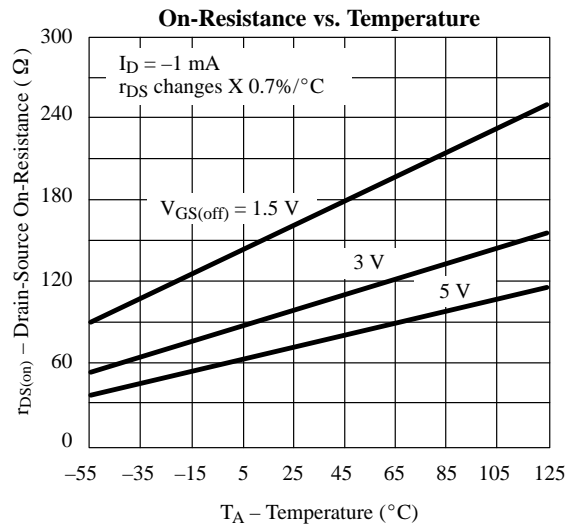
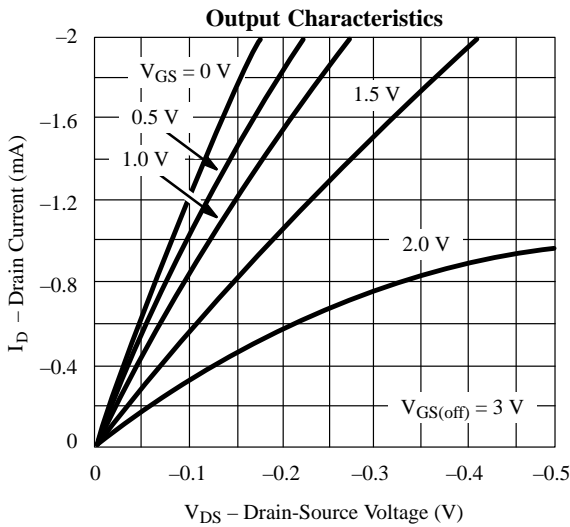
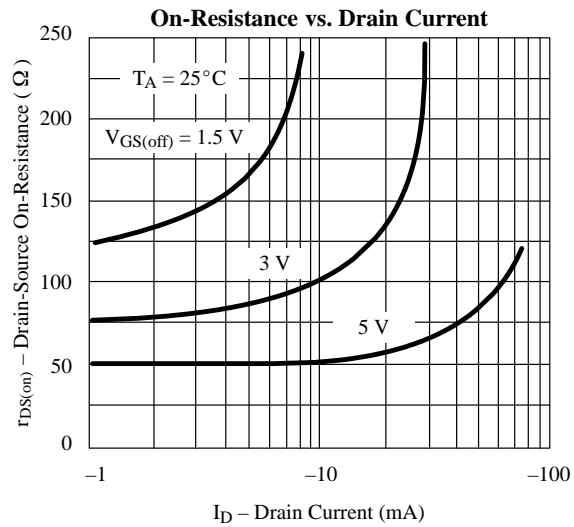
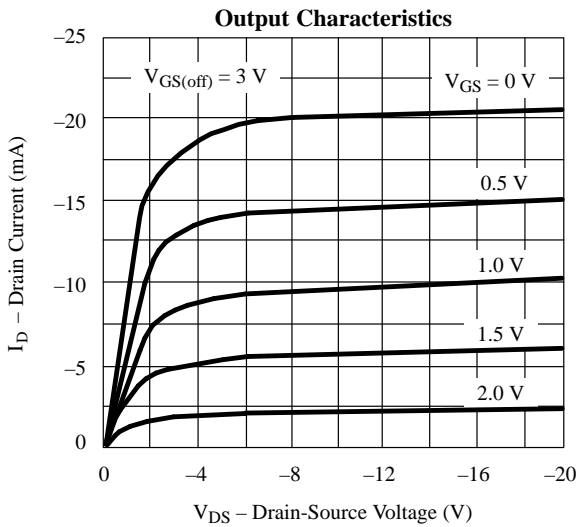
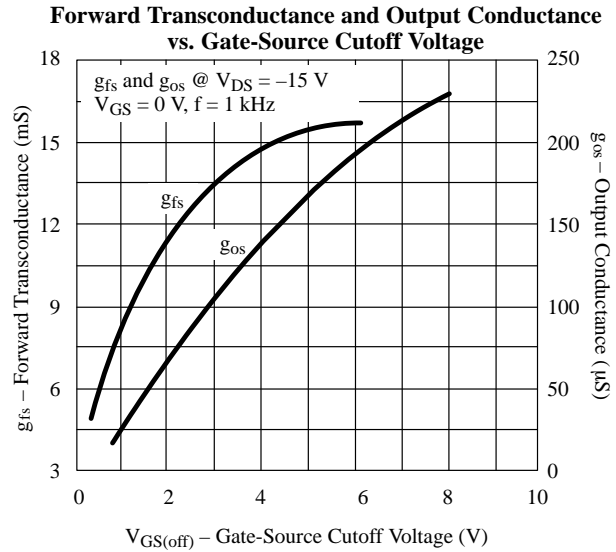
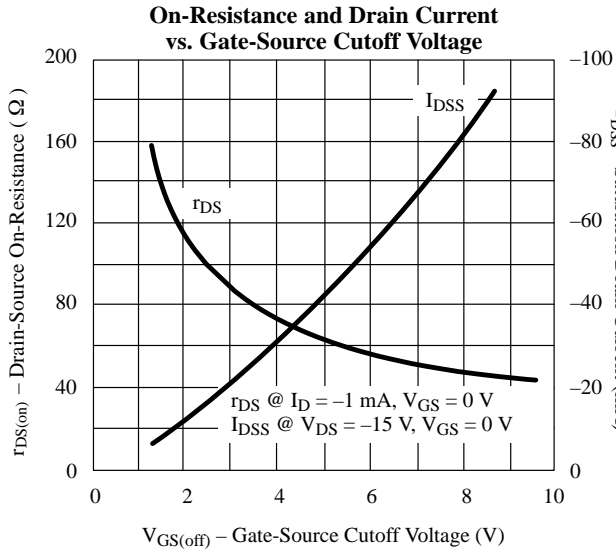

Typical Characteristics (Cont'd)

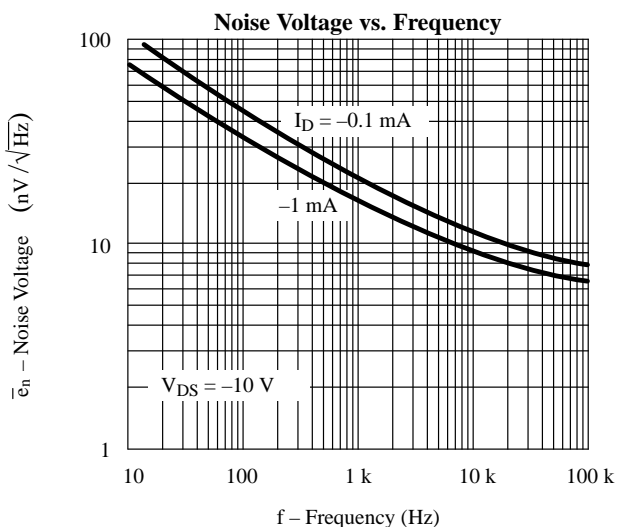
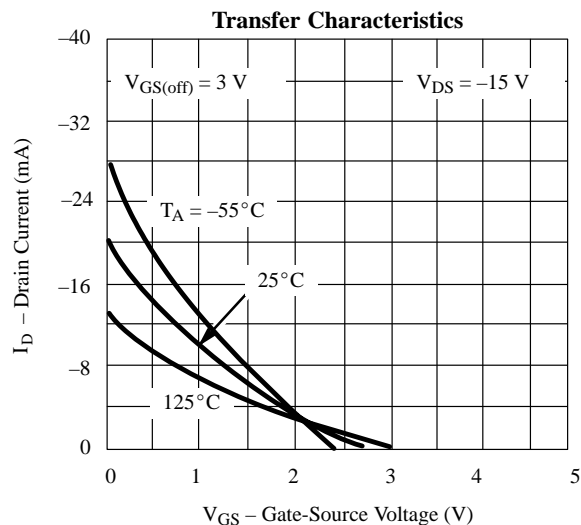
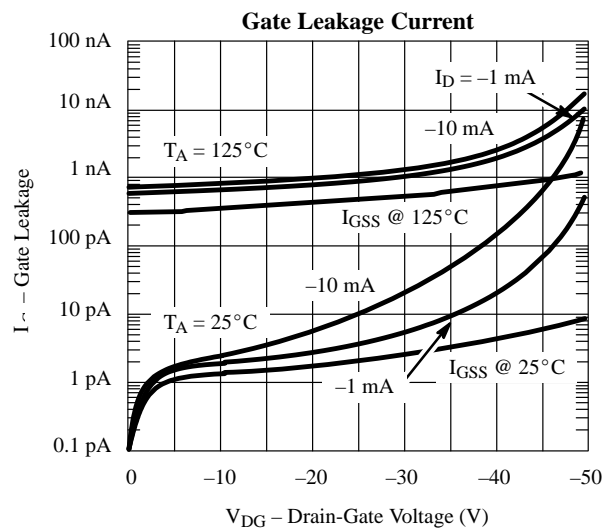
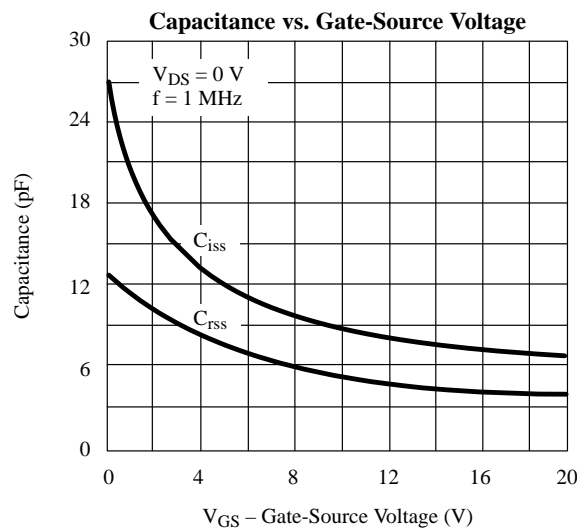
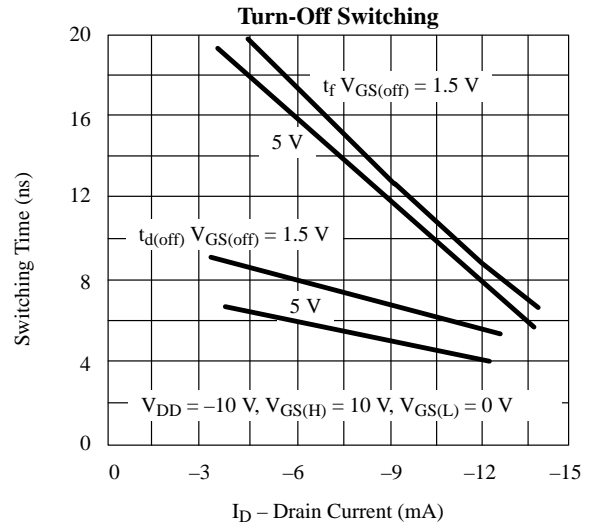
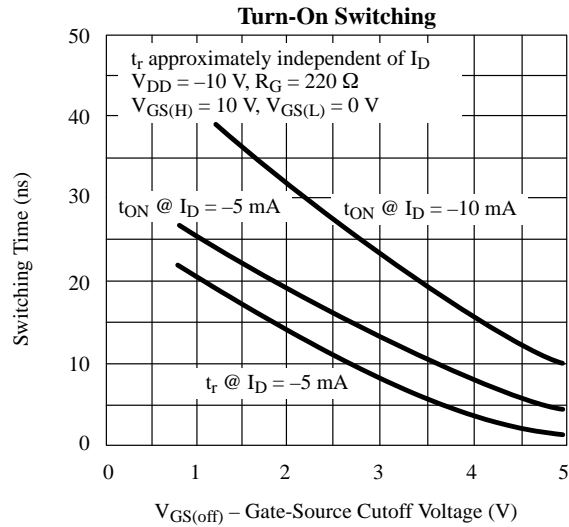

Switching Time Test Circuit

	174	175	176	177
V _{DD}	-10 V	-6 V	-6 V	-6 V
V _{GG}	20 V	12 V	8 V	5 V
R _L *	560 Ω	750 Ω	1800 Ω	5600 Ω
R _G *	100 Ω	220 Ω	390 Ω	390 Ω
I _{D(on)}	-15 mA	-7 mA	-3 mA	-1 mA

*Non-inductive

Input Pulse

Rise Time < 1 ns
Fall Time < 1 ns
Pulse Width 100 ns
PRF 1 MHz

Sampling Scope

Rise Time 0.4 ns
Input Resistance 10 MΩ
Input Capacitance 1.5 pF

See Typical Characteristics curves for changes.

