

Accessories & Modification Codes

Contents

<i>Description</i>	<i>Page</i>
Accessories	
<i>IT</i> NEMA	16-2
Freedom NEMA	16-4
Advantage NEMA	16-12
A200 NEMA	16-18
<i>XT</i> IEC	16-23
Enclosures	16-28
Lighting Contactors	16-30
<i>IT</i> Solid-State Soft Starters	16-36
Adjustable Frequency Drives	16-38
NEMA Vacuum Break Control	16-39
Modification Codes	16-40



Auxiliary Contacts

IT. NEMA

IT. NEMA

Auxiliary Contacts



Auxiliary Contacts are available for mounting on Eaton's Cutler-Hammer Intelligent Technologies (IT) Electro-Mechanical Contactors and Starters. The various choices available for non-reversing models are shown in Tables 16-1 and 16-2, and their ratings in Tables 16-3 – 16-5. For reversing models, the number of auxiliaries indicated is for each of the contactors/starters in the assembly.

Table 16-1. Auxiliary Contact Availability — Sizes 00 – 5

Top Mounted (Maximum Auxiliaries per Contactor/Starter) ②						
Contactor/Starter Size					Contact Type	Catalog Number
Size 00, 0	Size 1	Size 2	Size 3, 4	Size 5		
3	3	3	3	—	1NO	EMA13
3	3	3	3	—	1NC	EMA14
2	2 ①	3	3	—	1NO-1NC	EMA15
2	2 ①	3	3	—	2NO	EMA16
2	2 ①	3	3	—	2NC	EMA17
2	3	3	3	3	Logic Level 1NO-1NC	EMA70

① Other combinations: Single, Dual, Single; Dual, Single, Dual; Dual, Logic Level, Dual.
② For reversers, multiply quantities by two.

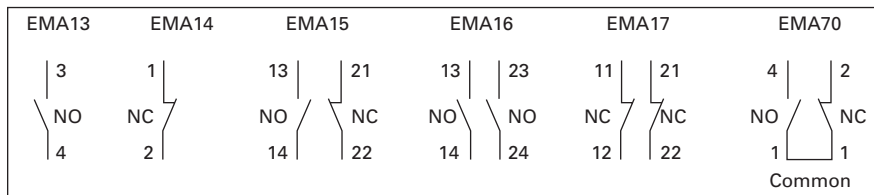

Figure 16-1. Connecting Diagram — Sizes 00 – 5

Table 16-2. Auxiliary Contact — Size 5

Auxiliary Contacts per Non-reversing and Reversing Contactor or Starter			
Max.	Contact Type	Description	Catalog Number
2	1NO	Base auxiliary (max. 1 per side)	C320KGS41
2	1NO-1NC	Base auxiliary (max. 1 per side)	C320KGS42
6	1NO	C320KGS41 or C320KGS42 required (max. 3 Add-on auxiliaries per side)	C320KGS20
2	1NO Logic Level	C320KGS41 or C320KGS42 required (max. 1 Add-on auxiliary per side)	C320KGS20L
6	1NC	C320KGS41 or C320KGS42 required (max. 2 Add-on auxiliaries per side)	C320KGS21
2	1NC Logic Level	C320KGS41 or C320KGS42 required (max. 1 Add-on auxiliary per side)	C320KGS21L
2	1NO-1NC	C320KGS41 or C320KGS42 required (max. 1 Add-on auxiliary per side)	C320KGS22
2	1NO-1NC Logic Level	C320KGS41 or C320KGS42 required (max. 1 Add-on auxiliary per side)	C320KGS22L ③
3	1NO-1NC Logic Level	Front Mounted Only	EMA70 ④

③ Form C contacts. ■ Maximum 4 auxiliaries per side (base + 3 side mounted).
④ For reversers, multiply quantities by two. ■ EMASA/B_ have been superseded by the above Catalog Numbers.
■ Side Mounted — Maximum (10) total circuits.
■ Front Mounted — Maximum (6) total circuits. ④

Table 16-3. IEC Ratings

DC-13		AC-15	
U _e Voltage	I _e Amps.	U _e Voltage	I _e Amps.
24	5	48	8
48	2.5	120	6
125	1.1	240	4
250	.55	440	2

Table 16-4. NEMA A600 Ratings

Current	AC Voltage			
	120	240	480	600
Make and Interrupting	60	30	15	12
Break	6	3	1.5	1.2
Continuous	10	10	10	10
Thermal	10	10	10	10

Table 16-5. NEMA P300 Ratings

Current	DC Voltage	
	125	250
Make and Interrupting	1.1	.55
Break	1.1	.55
Continuous	5	5
Thermal	5	5

Table 16-6. EMA70 Auxiliary Contact

DC-12		AC-12	
U _e	I _e	U _e	I _e
30	.1	250	.1

Table 16-7. C320KGS20L, C320KGS21L, C320KGS22L Auxiliary Contact Ratings

DC-12		AC-12	
U _e	I _e	U _e	I _e
80	0.1	250	0.1

Starter Network Adapter Product (SNAP)



Cat. No. D77B-DSNAP-X1 with 54 mm IT. Starter

The Starter Network Adapter Product (SNAP) is a front-mount device that serves as a single DeviceNet node, providing communication capability, control and monitoring to Eaton's Cutler-Hammer Intelligent Technologies (IT) Electromechanical Starters as well as the IT. S75X SoftStart.

When HAND-OFF-AUTO is required, the HOA option will allow for the connection of hard wired operators. This option allows for Hand Control even if the DSNAP is not connected.

For more information and pricing, see Publication No. CA08102001E, Tab 50.

Lug Kits



Table 16-8. Lug Kits

NEMA Size	Description	Catalog Number
1	Contact or Starter Line or Load (3 Lugs)	EMLUGKTC
2	Contact or Starter Line or Load	EMLUGKTD
3, 4	Contact Line or Load, Starter Line Starter Load	EMLUGKTLE EMLUGKTTE
5	Contact or Starter Line or Load, Horizontal Contact or Starter Line or Load, Vertical	EMLUGKTFA EMLUGKTFB

Table 16-9. Ring Lug Retrofit Kits

Product	NEMA Sizes 3, 4			NEMA Size 5		
	Catalog Number			Catalog Number		
	Factory Installed	Retrofit Kits ①	Lug Kits ②	Factory Installed	Retrofit Kits ①	Lug Kits ②
N111	Add "-RTX"	EMRTXKTEN	EMLUGREN	Add "-RTX"	EMRTXKTF	EMLUGRFC
N511	Add "-RTX"	EMRTXKTER	EMLUGRER	Add "-RTX"	EMRTXKTF	EMLUGRFC
N101	Add "-RTX"	EMRTXKTEN	EMLUGREN	Add "-RTX"	EMRTXKTF	EMLUGRFS
N501	Add "-RTX"	EMRTXKTER	EMLUGRER	Add "-RTX"	EMRTXKTF	EMLUGRFS
N05N	Add "-RTX"			Add "-RTX"		
N06N	Add "-RTX"			Add "-RTX"		
N02N	Add "-RTX"					
N03N	Add "-RTX"					
N04N	Add "-RTX"					

① Retrofit Kits used to field install ring lugs on standard lug units.

② Lug Kits used to field install standard lugs into factory assembled ring lug units.

Reversing Kits

Includes Fanning Strips, Mechanical Interlock, Mounting Plate and hardware.

Table 16-10. Reversing Kits ③

NEMA Size	Catalog Number
00, 0	EMRKTB
1	EMRKTC
2	EMRKTD
3, 4	EMRKTE
5	EMRKTF

③ For Contactor and Starter.

Note: Also order separately the appropriate contact blocks and overload relay.

Freedom NEMA

Freedom NEMA

Auxiliary Contacts

NEMA Sizes 00 – 2

The auxiliary contacts listed below are designed for installation on Freedom Series starters and contactors. Snap-on design facilitates quick, easy installation.

These bifurcated design contact blocks, featuring silver cadmium alloy contacts, are well suited for use in very low energy (logic level) circuits.



Side Mounted



Top Mounted

Table 16-11. Selection Product

Description	Contact Configuration Code ^①	Catalog Number
Side Mounted		
1NO	10	C320KGS1
1NC	01	C320KGS2
1NO-1NC	11	C320KGS3
2NO	20	C320KGS4
2NC	02	C320KGS5
1NO-1NCI	N/A	C320KGS6
1NO (EC)-1NC (LO)	N/A	C320KGS7
1NCI	N/A	C320KGS8
Top Mounted		
1NO	10	C320KGT1
1NC	01	C320KGT2
1NO-1NC	11	C320KGT3
2NO	20	C320KGT4
2NC	02	C320KGT5
1NO-1NCI	N/A	C320KGT6
1NO (EC)-1NC (LO)	N/A	C320KGT7
1NCI	N/A	C320KGT8
3NO	30	C320KGT9
2NO-1NC	21	C320KGT10
1NO-2NC	12	C320KGT11
3NC	03	C320KGT12
4NO	40	C320KGT13
3NO-1NC	31	C320KGT14
2NO-2NC	22	C320KGT15
1NO-3NC	13	C320KGT16
4NC	04	C320KGT17
3NO-1NCI	N/A	C320KGT18
2NO-1NCI-1NC	N/A	C320KGT19
2NO-1NO (EC)-1NC (LO)	N/A	C320KGT20
1NO-1NC-1NO (EC)-1NC (LO)	N/A	C320KGT21

Side Mounted

Note: NCI = Normally Closed early opening designed for use in reversing applications. EC = Early Closing. LO = Late Opening.

^① For reference only — not part of Catalog Number. See above right.

Contact Configuration Code

This two-digit code is found on the auxiliary contact to assist in identifying the specific contact configuration. The first digit indicates the quantity of NO contacts and the second indicates the quantity of NC contacts.

NEMA Sizes 3 – 8



Base Auxiliary Contact
Cat. No. C320KGS42



Auxiliary Contact
Cat. No. C320KGS22

Table 16-12. Product Selection

Circuit	Contact Configuration Code ^②	Catalog Number
---------	---	----------------

Base Auxiliary Contacts — NEMA Sizes 3 – 5

NO	NC	NEMA Size 3	NEMA Sizes 4 – 5
10	11	C320KGS31	C320KGS41
		C320KGS32	C320KGS42

Auxiliary Contacts — NEMA Sizes 3 – 5

NO	NC	NO-NC ^③	Catalog Number
10	01	11	C320KGS20
			C320KGS21
			C320KGS22

Auxiliary Contacts — NEMA Sizes 6 – 8

NO-NC	2NO-2NC	Size	Catalog Number
11	22	NEMA 8	C320KA5
		NEMA 6 – 7	C320KA6

^② For reference only — not part of Catalog Number. See above.

^③ NO-NC occupies two positions — L2 and L3, or R2 and R3. See next page.

Auxiliary Contact Ratings (Amperes)

Table 16-13. Ratings — NEMA A600

Current	AC Volts			
	120V	240V	480V	600V
Make and Interrupting	60	30	15	12
Break	6	3	1.5	1
Continuous	10	10	10	10

Table 16-14. Ratings — NEMA P300

Continuous Thermal Rating: 5A	
DC Volts	Make/Break Amperes
125	1.10
250	.55

Table 16-15. Ratings — Logic Level

Minimum Ratings for Logic Level and Hostile Atmosphere Application	
Minimum Amperes	20 mA
Minimum Volts	24V AC/DC

Table 16-16. Ratings — C320KGS20L, C320KGS21L, C320KGS22L

DC-12		AC-12	
Ue	Ie	Ue	Ie
80	0.1	250	0.1

Auxiliary Contact Location

NEMA Sizes 00 – 2

The sketches below illustrate the maximum number of auxiliary contacts that can be assembled to a contactor or starter and their locations.

Table 16-17. Auxiliary Contacts

Catalog Number	Size	Poles	Available Mounting Positions ①②	
			Open Type	Enclosed
AN16	00	3	T1, L1, R1	L1
	0 – 2	3	T1, L1	L1
AN56	00 – 2	3	T1, T2	—
CN15	00	2 – 4	T1, L1, R1	L1
	0 – 2	2 – 3	T1, L1	L1
	1, 2	4	T1, L1	—
	1, 2	5	T1, L1	—
CN35	10A	2 – 4	T1, L1, R1	L1
	20 – 60A	2 – 3	T1, L1	L1
	60A	4	T1, L1	—
	60A	5	T1, L1	—
CN55	00 – 2	3	T1, T2	—

① Available positions on contactors or starters other than what is factory installed.

② When a pneumatic timer is mounted on contactor, only side mounted auxiliary contact positions are available. The solid-state timer, when added, takes up side mounted auxiliary contact position.

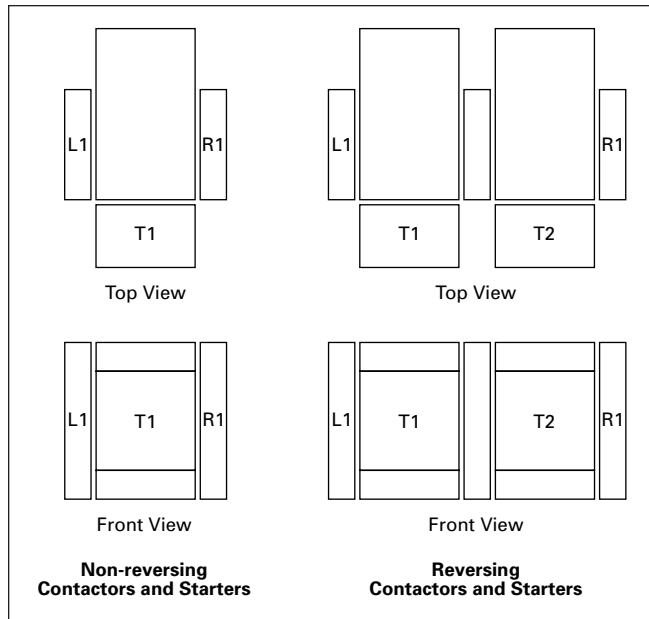

Figure 16-2. Auxiliary Contact Location

NEMA Sizes 3 – 8

The sketches below illustrate the maximum number of auxiliary contacts that can be assembled to a contactor and their locations.

Note: A Base Auxiliary Contact must be added in position R1 before additional auxiliary contacts can be mounted on NEMA Size 3 or in L1 on NEMA Sizes 4 – 5.

Table 16-18. Mounting Positions

Size	Available Mounting Positions ③
NEMA Size 3	R2, R3, L1, L2, L3
NEMA Sizes 4 – 5	L2, L3, R1, R2, R3
NEMA Sizes 6 – 7	R1
NEMA Size 8	L2, R2

③ Available positions on contactors or starters other than what is factory installed.

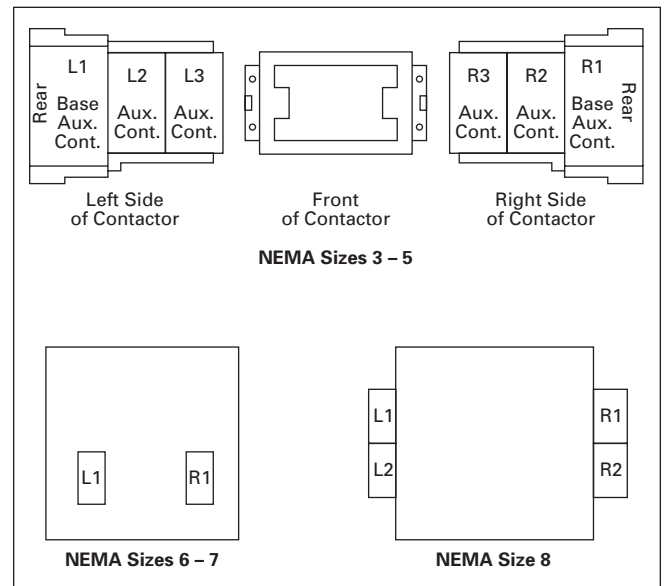

Figure 16-3. Auxiliary Contact Location

Freedom NEMA

Heater Pack Selection

Heater packs H2001B to H2017B and H2101B to H2117B are to be used only with Series B overload relays Catalog Numbers C306DN3B (Part No. 10-7016) and C306GN3B (Part No. 10-7020). The load lugs are built into the overload relay base

Table 16-19. Starters with Series B Overload Relays

NEMA — AN Type	
Size	Series
00 – 0	C
1 – 2	B
5	B
6	C
7 – 8	B

Table 16-20. Fast Trip — Class 10 Heater Selection

Overload Relay Size	Motor Full Load Ampere Rating				Catalog Number (Includes 3 Heater Packs) ①
	Dial Position				
	A	B	C	D	

For Use with NEMA Sizes 00 – 0 Series C, NEMA Sizes 1 – 2 Series B

32A or 75A	.260	.313	.367	.420	H2101B-3
	.384	.464	.543	.623	H2102B-3
	.570	.688	.806	.924	H2103B-3
	.846	1.02	1.20	1.37	H2104B-3
	1.28	1.55	1.83	2.10	H2105B-3
	1.92	2.33	2.74	3.15	H2106B-3
	2.30	2.79	3.28	3.77	H2107B-3
	3.38	4.10	4.82	5.54	H2108B-3
	4.96	6.03	7.09	8.16	H2109B-3
	7.07	8.58	10.1	11.6	H2110B-3
75A	9.60	11.2	12.8	14.4	H2111B-3
	14.4	17.5	20.7	23.8	H2112B-3
	18.7	21.8	25.0	28.1	H2113B-3
	23.5	27.3	31.0	34.8	H2114B-3

For Use with NEMA Size 2 — Series B

75A	28.3	32.6	37.0	41.3	H2115B-3
	36.6	42.3	48.1	53.8	H2116B-3
	53.8	60.8	67.9	74.9	H2117B-3

For Use with Size 5 Starters Only — Series B

32A ②	51	61	72	82	H2104B-3
	77	93	110	126	H2105B-3
	115	140	164	189	H2106B-3
	138	167	197	226	H2107B-3
	203	246	289	—	H2108B-3

For Use with Size 6 Starters Only — Series B

32A ②	154	186	220	252	H2105B-3
	230	280	329	378	H2106B-3
	276	335	394	452	H2107B-3
	406	492	578	—	H2108B-3

For Use with Size 7 Starters Only — Series B

32A ②	169	204	240	274	H2104B-3
	256	310	366	420	H2105B-3
	384	466	543	630	H2106B-3
	460	558	656	754	H2107B-3
	676	820	—	—	H2108B-3

For Use with Size 8 Starters Only — Series B

32A ②	254	306	360	411	H2104B-3
	384	465	549	630	H2105B-3
	576	699	822	945	H2106B-3
	690	837	984	1131	H2107B-3
	1014	1230	—	—	H2108B-3

① Heater packs are shipped 3 to a carton. Catalog Numbers are for 3 heater packs.

② Sizes 5 – 8 use the 32A overload relay with current transformers.

to allow load wiring prior to heater pack installation. The previous heater design had integral load lugs. The Series B heater packs are electrically equivalent to the previous heater design. Heaters H2018-3 to H2024-3 have not changed.

Note: The series of a starter is the last digit of the listed Catalog Number. EXAMPLE: AN16DN0AB.

Table 16-21. Standard Trip — Class 20 Heater Selection

Overload Relay Size	Motor Full Load Ampere Rating				Catalog Number (Includes 3 Heater Packs) ③
	Dial Position				
	A	B	C	D	

For Use with NEMA Sizes 00 – 0 Series C, NEMA Sizes 1 – 2 Series B

32A or 75A	.254	.306	.359	.411	H2001B-3
	.375	.452	.530	.607	H2002B-3
	.560	.676	.791	.907	H2003B-3
	.814	.983	1.15	1.32	H2004B-3
	1.20	1.45	1.71	1.96	H2005B-3
	1.79	2.16	2.53	2.90	H2006B-3
	2.15	2.60	3.04	3.49	H2007B-3
	3.23	3.90	4.56	5.23	H2008B-3
	4.55	5.50	6.45	7.40	H2009B-3
	6.75	8.17	9.58	11.0	H2010B-3
75A	9.14	10.8	12.4	14.0	H2011B-3
	14.0	16.9	19.9	22.8	H2012B-3
	18.7	22.7	26.7	30.7	H2013B-3
	23.5	28.5	33.5	38.5	H2014B-3

For Use with NEMA Size 2 — Series B

75A	29.0	34.0	39.1	44.1	H2015B-3
	39.6	45.5	51.5	57.4	H2016B-3
	53.9	60.9	67.9	74.9	H2017B-3

For Use with NEMA Sizes 3 – 4 — Series A

105A or 144A	8.0	9.2	10.3	11.5	H2025-3
	11.4	12.8	14.3	15.7	H2026-3
	14.3	15.7	17.4	19.0	H2027-3
	18.0	20.2	22.3	24.5	H2018-3
	24.6	27.6	30.5	33.4	H2019-3
	33.5	37.5	41.5	45.6	H2020-3
	45.7	51.2	56.7	62.1	H2021-3
	62.2	69.7	77.1	84.6	H2022-3
	84.7	95.0	105.0	115.0	H2023-3
	106.0	118.0	131.0	144.0	H2024-3

For Use with Size 5 Starters — Series B

32A ④	49	59	69	79	H2004B-3
	72	87	103	118	H2005B-3
	107	130	152	174	H2006B-3
	129	156	182	209	H2007B-3
	194	234	274	—	H2008B-3

For Use with Size 6 Starters Only — Series B

32A ④	144	174	205	235	H2005B-3
	215	259	304	348	H2006B-3
	258	312	365	419	H2007B-3
	388	468	547	627	H2008B-3

For Use with Size 7 Starters Only — Series B

32A ④	163	197	230	264	H2004B-3
	240	290	342	392	H2005B-3
	358	432	506	580	H2006B-3
	430	520	608	698	H2007B-3
	646	780	912	—	H2008B-3

For Use with Size 8 Starters Only — Series B

32A ④	244	295	345	396	H2004B-3
	360	435	513	588	H2005B-3
	537	648	759	870	H2006B-3
	645	780	912	1047	H2007B-3
	969	1170	1368	—	H2008B-3

③ Heater packs are shipped 3 to a carton. Catalog Numbers are for 3 heater packs.

④ Sizes 5 – 8 use the 32A overload relay with current transformers.

Freedom NEMA

DC Magnet Coils

When Ordering Specify

Conversion Kit for Field Assembly

- Catalog Number

Factory Installed DC Coil

- For factory installed DC magnet coil on AC contactors or non-combination starters (open type only), substitute the Code Suffix from table below for the magnet coil identifier in the device Catalog Number.

EXAMPLE: For Size 0 AC contactor with a 24V DC coil, change CN15BN3AC to CN15BN3T1C.

Application

- Connect for separate control
- Not for use with cover control switch operators
- Use twin break, heavy-duty pilot devices
- Designed for +10%, -20% rated voltage, continuous duty operation

Non-reversing Kit Consists of:

- 1 Encapsulated DC magnet coil
- 1 NCI or NO/NCI side mounted auxiliary contact

Note: These kits are supplied with a NO/NCI side mounted auxiliary contact in place of the NCI contact.

- 2 Blue colored connection wires
- 1 Instruction publication

Operation

These DC coil kits have separate pick-up and seal windings. A **special** (side mounted) early-break NCI auxiliary contact is used to either disconnect the pick-up winding or insert the seal winding in series with the pick-up winding, depending on the frame size of the contactor. DC coil kits come in two styles, a suffix **1** and a suffix **4**. The **1** suffix contains only the **special** (side mounted) early break NCI auxiliary contact. The **4** suffix contains a NO contact in the same package as the **special** (side mounted) early-break NCI auxiliary contact.

Note: For NEMA Sizes 00 and 0 contactors may utilize either suffix 1 or 4 DC coil kits; starters may utilize suffix 4 DC coil kits only. For NEMA Sizes 1 and 2, both contactors and starters may utilize a suffix 4 DC coil kit only.

On the above sizes only, when the **special** auxiliary package is mounted on the side of a contactor or starter, **no** standard auxiliary contact may be mounted on the same side.

Note: For NEMA Sizes 3 – 5, the special coil NCI clearing contact is an add-on auxiliary (**must** mount on a base mount auxiliary contact; normally a 1NO). This arrangement will normally account for two of the three contact positions on the side of each contactor or starter.

See **Figure 16-4, Page 16-8.**

Table 16-22. Product Selection

Contactor or Starter Size	Conversion Data				Complete Conversion Kit		Factory Installed	
	Volts	Magnet Coil	NCI Interlock Number		Catalog Number	Ship Wt. Lbs. (kg)		Code Suffix
NEMA		Coil Number	Amps P.U./Seal	Watts P.U./Seal				
Non-reversing — Kit includes NCI Side Mounted Auxiliary Contact								
00 and 0 CN35 – A, B, D D15 Relays	12 24 48 120	9-2988-11 9-2988-12 9-2988-13 9-2988-14	6.4/.28 3.2/.14 1.6/.07 .64/.028	76.8/3.36 76.8/3.36 76.8/3.36 76.8/3.36	C320KGD1 C320KGD1 C320KGD1 C320KGD1	C335KD3R1 C335KD3T1 C335KD3W1 C335KD3A1	1.0 (.5)	R1 T1 W1 A1
① 00 and 0 CN35 – A, B, D D15 Relays	12 24 48 120	9-2988-11 9-2988-12 9-2988-13 9-2988-14	6.4/.28 3.2/.14 1.6/.07 .64/.028	76.8/3.36 76.8/3.36 76.8/3.36 76.8/3.36	C320KGD2 ① C320KGD2 ① C320KGD2 ① C320KGD2 ①	C335KD3R4 C335KD3T4 C335KD3W4 C335KD3A4	1.0 (.5)	R4 T4 W4 A4
1 and 2 CN35 – G	12 24 48 120	9-2990-1 9-2990-2 9-2990-3 9-2990-4	15.4/.42 7.7/.21 3.9/.11 1.5/.041	185/4.98 185/4.96 185/5.04 185/4.87	C320KGD5 C320KGD5 C320KGD5 C320KGD5	C335KD4R4 C335KD4T4 C335KD4W4 C335KD4A4	1.0 (.5)	R4 T4 W4 A4
3 CN35 – K	12 24 48 120	9-3002-1 9-3002-2 9-3002-3 9-3002-4	24/.40 12/.20 6.1/.097 2.5/.038	293/4.84 288/4.75 295/4.67 298/4.57	C320KGD3 C320KGD3 C320KGD3 C320KGD3	C335KD5R1 C335KD5T1 C335KD5W1 C335KD5A1	2.0 (.9)	R1 T1 W1 A1
4 and 5 CN35 – N, S	24 48 120 240	9-2026-4 9-2026-3 9-2026-2 9-2026-1	18/.22 9/.11 3.3/.05 1.7/.02	400/5.3 400/5.2 450/5.4 440/4.9	C320KGD3 C320KGD3 C320KGD3 C320KGD3	C335KA3T1 C335KA3W1 C335KA3A1 C335KA3B1	2.5 (1.1)	T1B W1B A1B B1B
Reversing								
00 and 0 CN35 – A, B, D D15 Relays	12 24 48 120	9-2988-1 9-2988-2 9-2988-3 9-2988-4	6.4/.28 3.2/.14 1.6/.07 .64/.028	76.8/3.36 76.8/3.36 76.8/3.36 76.8/3.36	C320KGD1 C320KGD1 C320KGD1 C320KGD1	C335KD3R1 ② C335KD3T1 ② C335KD3W1 ② C335KD3A1 ②	1.0 (0.9)	R1 ③ T1 ③ W1 ③ A1 ③
1 and 2 CN35 – G	12 24 48 120	9-2990-1 9-2990-2 9-2990-3 9-2990-4	15.4/.42 7.7/.21 3.9/.11 1.5/.041	185/4.98 185/4.96 185/5.04 185/4.87	C320KGD3 C320KGD3 C320KGD3 C320KGD3	④ ④ ④ ④	—	R1 ③ T1 ③ W1 ③ A1 ③

① These kits are supplied with a NO/NCI side mounted auxiliary contact in place of the NCI contact.
 ② Kit does not include mechanical interlock or crossover wiring. Two NO/NCI top mounted auxiliary contacts are supplied for electrical interlocking.
 ③ Factory installed DC coils on NEMA contactors and starters include a NO/NCI top mounted auxiliary contact on each contactor for electrical interlocking.
 ④ Available factory assembled only.

Freedom NEMA

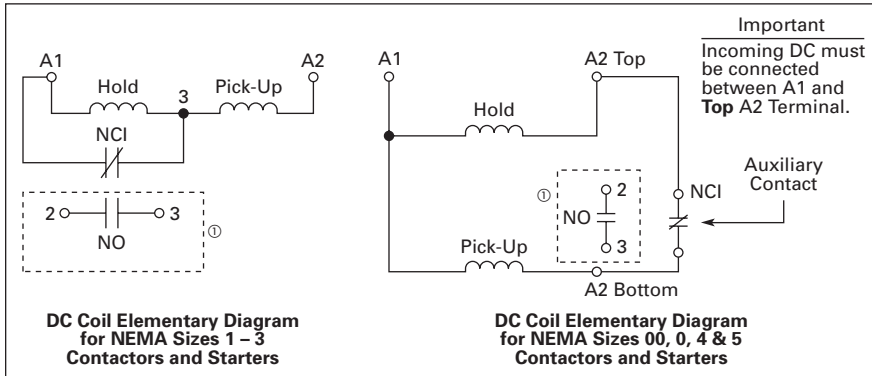

Figure 16-4. Elementary Diagrams

① 1NO available in Suffix 4 kits only.

Remote Reset Module (32A Overload Relay)

The C316RR remote reset module for the C316F, C316S and C316U overload relays allows remote resetting of tripped (32A) overload relays by means of an electrical solenoid attachment which mounts on the side of the overload relay.

Table 16-23. Product Selection

Remote Reset Module Operating Voltage	Catalog Number
24V 50/60 Hz	C316RR1U
110V 50/60 Hz	C316RR1A

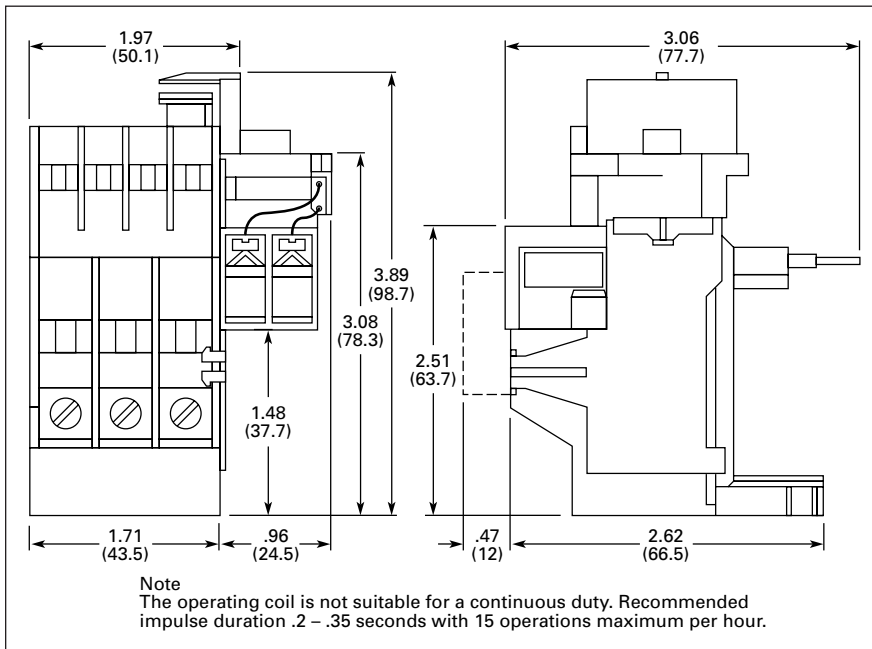

Figure 16-5. Remote Reset Module — Approximate Dimensions in Inches (mm)

3-Pole Top Mounted Fuse Block Kit

NEMA Sizes 00 – 2



Field mount to Freedom Series starters and contactors. Designed to save space and reduce installation costs. They provide short circuit protection for branch circuits.

Mounted Fuse Block Kit

Table 16-24. Fuse Block Kits

Fuse Type	Catalog Number
Class H — 30A 250V	C350KH21
Class R — 30A 250V	C350KR21
Class G — 15A 300V	C350KG37
Class G — 20A 300V	C350KG38
Class G — 30A 300V	C350KG31
Class G — 60A 300V	C350KG32
Class T — 30A 300V	C350KT31
Class T — 60A 300V	C350KT32
Class J — 30A 600V	C350KJ61
Class J — 60A 600V	C350KJ62
Type M — 30A 600V ①	C350KM61
Class CC — 30A 600V	C350KC63
Class T — 30A 600V	C350KT61
Class T — 60A 600V	C350KT62

① Type M fuse block not approved for branch circuit protection.

Table 16-25. Approximate Dimensions

Fuse Block			Dimensions in Inches (mm)			
Class	Amperes	Volts	Wide A	High B	Deep C	D
G	15, 20, 30	300	2.40 (61.0)	3.00 (76.2)	2.04 (51.8)	—
	60	300	2.62 (66.5)	4.25 (108.0)	2.08 (52.8)	—
H	30	250	3.00 (76.2)	3.10 (78.7)	2.23 (56.6)	3.62 (91.9)
J	30, 60	600	4.81 (122.2)	4.12 (104.6)	2.82 (71.6)	—
M, CC	30	600	2.40 (61.0)	3.00 (76.2)	2.04 (51.8)	—
R	30	250	3.00 (76.2)	3.10 (78.7)	2.23 (56.6)	3.62 (91.9)
	30	600	3.44 (87.4)	3.00 (76.2)	2.33 (59.2)	—
	60	600	3.75 (95.3)	3.31 (84.1)	2.26 (57.4)	—
T	30	300	4.87 (123.7)	3.00 (76.2)	2.58 (65.5)	—
	30	600	—	—	—	—
	60	600	—	—	—	—

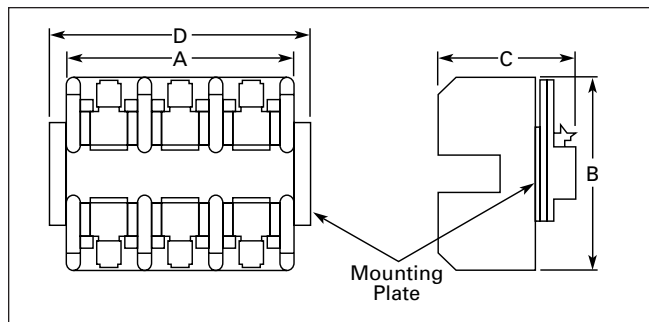

Figure 16-6. Approximate Dimensions in Inches (mm)

Mechanical Interlock and Reversing Kits

Mechanical interlocks and reversing kits are designed for field assembly of reversing contactors or starters from Freedom Series components. The Reversing Kits include a Mechanical Interlock, stabilizer bar and a pre-cut, trimmed and formed wire set. Auxiliary contacts, if required, must be ordered separately. See **Page 16-4**.



Cat. No.
C321KM60B



Part No.
23-7165

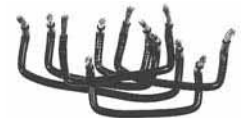

Wire Set

Table 16-26. Mechanical Interlock Only ②③

Application		Catalog Number
NEMA Size	Contacting Mounting	
00 – 2	Horizontal	C321KM60B
3	Horizontal	C321KM30
3 to 4	Horizontal	C321KM43
4	Horizontal	C321KM40
4 to 5	Horizontal	C321KM45
4 to 6	Horizontal	C321KM80
5	Horizontal	C321KM50
5 to 6	Horizontal	C321KM56
6	Horizontal	C321KM70
6 to 7	Horizontal	C321KM90
7	Horizontal	C321KM34
4 or 5 to 5	Vertical	C321KM55
5 to 6	Vertical	C321KM65
6	Vertical	C321KM66
6 to 7	Vertical	C321KM67

② Without cross-wiring.

③ For use with latest series product.

Table 16-27. Reversing Kits (Horizontal Contactor Mounting Only)

Application	Catalog Number
NEMA Size	
00	C321KM60K14B
0	C321KM60K13B
1	C321KM60K15B
2	C321KM60K16B
3	C321KM60K17 ④
—	C321KM60K21 ④
—	C321KM60K18 ④
4	C321KM60K19 ④
5	C321KM60K20 ④
—	C321KM60K44 ④

④ Kit includes (2) NC auxiliary contacts.

Freedom NEMA

Solid-State Timers

Solid-State ON DELAY Timer — Side Mounted on Freedom Series NEMA 00 – 2 and C25D, C25E and C25F Frame



This timer is designed to be **wired in series with the load** (typically a coil). When the START button is pushed (power applied to timer), the ON DELAY timing function starts. At the completion of the set timing period, timer and series wired load will both be energized.

Table 16-28. Mounted Timer Product Selection

Timing Range	Catalog Number ①②③
.1 – 1.0 Seconds	C320TDN1
1 – 30 Seconds	C320TDN30
30 – 300 Seconds	C320TDN300
5 – 30 Minutes	C320TDN2000

- ① Add operating voltage Suffix to Catalog Number. A = 120V, B = 240V, E = 208V
- ② Rated .5 ampere pilot duty – not to be used on larger contactors.
- ③ Terminal connections are quick connects only. Two per side.

Shorting Bar Kits

These kits provide phase-to-phase power connections of contactors for field assembly. The kits include bus connections and mounting hardware. The shorting bars connect all three phases of a single contactor.

Table 16-29. Product Selection

Description	Catalog Number
NEMA Size 3	C321SB18
NEMA Size 4	C321SB19
NEMA Size 5	C321SB21
NEMA Size 6	C321SB22

Pneumatic Timers — Top Mounted



Attachment mounts on top of any NEMA Size 00 – 2 Freedom Series starter or contactor (top mounted auxiliary contacts can not be installed on device when timer is used). Timer unit has 1NO-1NC isolated timed contacts — circuits in each pole must be the same polarity. Units are convertible from OFF to ON DELAY or vice-versa.

Table 16-30. Product Selection

Timing Range	Catalog Number
.1 to 30 Seconds	C320TP1
10 to 180 Seconds	C320TP2

Table 16-31. Maximum Ampere Ratings

Description	Volts AC			
	120	240	480	600
Make	30	15	7.5	6
Break	3	1.5	.75	.6

Locking Cover for Overload Relay — C306 Only

Snap-on transparent or opaque plastic panel for covering access port to the overload relay trip setting dial — helps prevent accidental or unauthorized changes to trip and reset setting.

Table 16-32. Product Selection

	Description	Minimum Ordering Qty. (Std. Pkg.)	Catalog Number
	Clear cover, no accessibility	50	C320PC3
	Gray cover, no accessibility, with Auto only nib	50	C320PC4
	Gray cover, no accessibility, with Manual only nib	50	C320PC5
	Gray cover with FLA dial accessibility, A, B, C, D positions and Auto only nib	50	C320PC6
	Gray cover with FLA dial accessibility, A, B, C, D positions and Manual only nib	50	C320PC7

Control Circuit Fuse Block



These panel mounted fuse holders, designed for control circuit protection or other similar low current requirements, have extractor type fuse caps. The Class CC rejection type fuses (KTK-R) used in these holders are intended for use with equipment designated as being suitable for use on systems having high available fault currents. If branch circuit protective device is 45A or greater, C320FBR fuse kit may be required for control circuit protection per NEC 430-72.

Table 16-33. Product Selection

Type	Max. Amperes	Catalog Number
Fuse Holder Only	15	C320FB ④
	30	C320FBR ⑤

- ④ A fuse is not supplied, but holder will accept a Bussman Type KTK or KTK-R (13/32" x 1-1/2") fuse, 600V maximum.
- ⑤ Includes a 5A, 600V KTK-R fuse.

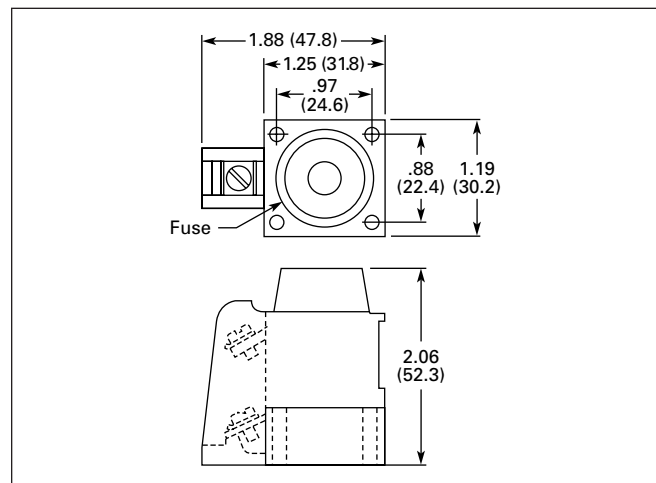

Figure 16-7. Approximate Dimensions in Inches (mm)

Freedom NEMA

Finger Protection Shields

Snap-on shields for both contactors and starters provide Type IP20 Finger Protection. Prevents accidental contact with line/load terminals.

Table 16-34. Product Selection

Application	Catalog Number
NEMA Size 00 NEMA Size 0	C320LS1 C320LS2
NEMA Sizes 1 – 2 Contactors Reversing Contactors	C320LS3 C320LS4
NEMA Size 1 Starters Reversing Starters	C320LS5 C320LS6
NEMA Size 2 Starters Reversing Starters	C320LS7 C320LS8

Adapter to DIN Rail Mount

NEMA 1 – 2 Contactors

Designed to allow DIN rail mounting of NEMA 1 – 2 contactors. Includes all hardware required to convert contactors from panel mounting to 35 mm DIN rail mounting.

Table 16-35. Product Selection

Description	Catalog Number
Adapter to DIN Rail Mount	C320DN65

Transient Suppressor Kits

NEMA Sizes 00 – 2



Cat. No. C320TS2

These kits limit high voltage transients produced in the control circuit when power is removed from the contactor or starter coil. There are three separate suppressors for use on 24 – 120V, 208 – 240V or 277 – 480V coils respectively.

These devices mount directly to the coil terminals of Freedom Series contactors or starters NEMA Sizes 00 – 2 and lighting contactors 10 – 60A. Reversing devices will require two.

Table 16-36. Product Selection

Description	Coil Voltage 50/60 Hz ①	Catalog Number
Transient Suppressor	24 – 120V 208 – 240V 277 – 480V	C320TS1 C320TS2 C320TS3

① Suppressor is compatible with coil voltages/ranges as shown, 50 and 60 Hz.

NEMA Sizes 3 – 5



This device mounts on top of any side mounted auxiliary contact on Freedom Series NEMA Sizes 3 – 5 and lighting contactors 100 – 300A.

It connects across coil terminals on any 120V contactor or starter magnet coil (reversing starters or contactors require 2).

Limits high voltage transients produced in the circuit when power is removed from the coil.

Table 16-37. Product Selection

Description	Coil Voltage	Catalog Number
Transient Suppressor	120V	C320AS1

DC/AC Interface Module

The Catalog Number C320DC Interface Module is an optically isolated solid-state switch which provides a means of operating AC coils with 5 – 48V DC control signal. It acts as a space saving interposing relay which can switch a specified 50/60 Hz AC source to the contactor or starter coil.



Cat. No. C320DC

The module may be directly attached to the coil terminals of any Freedom Series contactor or starter — NEMA Sizes 00 – 3 and lighting contactors 10 – 100A. It also has provisions for DIN rail mounting.

The module will operate coils within the voltage ranges shown in **Table 16-38**.

Design Characteristics

- DC Input: 5 – 48V DC at mA nominal
- AC Operating Voltage: 240V AC (360 VA) ±10% 50/60 Hz;
- DC Operating Voltage: 30V DC max. (.5A)

Add-On Power Pole Kit

NEMA Sizes 00 – 2

This device mounts on the side of Freedom NEMA Size 00 – 2 contactors. One unit can be mounted on each side and carries UL, cUL and IEC ratings. The device is rated for resistive, inductive and lighting applications.

Table 16-41. Product Selection — Add-On Power Pole Kit

UL Ampere Rating				IEC 947 Ampere Rating			1NO Power Pole Catalog Number		
Inductive 600V	Resistive 600V	hp 1-Phase		Locked Rotor 240V	Lighting Ballast Tungsten 480V	AC-1 600V		AC-3 600V	AC-5a AC-5b 480V
		115V	230V						
15	20	1/2	2	96	20	20	12	18	C320PPD10

- AC Current Rating
 - 10A make (inrush)
 - 1A break (sealed)

Table 16-38. Controller Coil Voltage Ranges

Controller Catalog Number Prefix	Controller Size or Rating	Coil Range Volts AC
AN16, AN56, CN15, CN55	00 – 0 1 – 2 3	24 – 240 48 – 240 110 – 240
CN35	10 – 30A 60A 100A	24 – 240 48 – 240 110 – 240

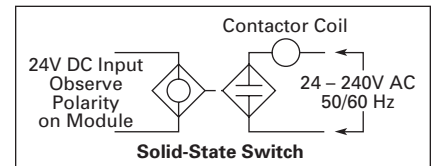

Figure 16-8. Typical Application

Table 16-39. Product Selection

Coil Voltage	Catalog Number
5V DC	C320DC2V5
6V DC	C320DC2V6
9V DC	C320DC2V9
12V DC	C320DC2V12
48V DC	C320DC2V48

Adhesive Dust Cover

NEMA Sizes 00 – 2

These adhesive stickers come 25 to a package and provide extra protection from contaminants when applied to the sides of Freedom NEMA Sizes 00 – 2. Adhesive covers are easily applied to side opening where auxiliaries are not installed and provide extra protection from metal filings and other debris.

Table 16-40. Product Selection

Description	Catalog Number
25 to a package	C320DSTCVR

Freedom NEMA, Advantage NEMA

Fuse Clips



C351 Fuse Clip Kit

Table 16-42. C351 — Fuse Clip Selection — 3 Poles

Starter Size	Motor Voltage	Maximum hp (3-Phase)	Fuse Clip Rating		Fuse Clip Kit for Field Installation in Non-fusible Starter		Fuse Clip Kit Factory Installed
			Amperes	Volts	For Non-rejection Type Fuses	For use w/ "R" Rejection Type Fuses	
		Dual Element Fuses			Catalog Number	Catalog Number	Position 10 Alpha ^②
Non-fusible — without Fuse Clips Installed							
0	200/230 460/575	3 5	30 30	250 600	C351KC21 C351KD22-61	C351KC21R C351KD22-61R	A B C
1	200/230 460/575	7-1/2 10	30 30	250 600	C351KC21 C351KD22-61	C351KC21R C351KD22-61R	B C
2	200 230 460/575	10 15 25	60 60 60	250 250 600	C351KD22-61 C351KD22-61 C351KD62	C351KD22-61R C351KD22-61R C351KD62R	D D E
3	200 230 460/575	25 30 50	100 100 100	250 250 600	C351KE23-63 ^① C351KE23-63 ^① C351KE23-63 ^①	C351KE23-63 ^① C351KE23-63 ^① C351KE23-63 ^①	F F G
4	200 230 460/575	40 50 100	200 200 200	250 250 600	C351KF24-64 ^① C351KF24-64 ^① C351KF24-64 ^①	C351KF24-64 ^① C351KF24-64 ^① C351KF24-64 ^①	H H J
5	200 230 460/575	75 100 200	400 400 400	250 250 600	Not Available in Kit Form	Not Available in Kit Form	K K L

^① Fuse clip "R" rejection members for use with Class R fuses are supplied loose in the Fuse Clip Kits.

^② These fuse clips are for Class R fuses.

Note: Kits do not include fuses.

Control Power Transformer Kits



Control Transformer Kit

These control transformer kits provide a convenient on-the-job addition of control transformers to the following Type 1, 3R, 4/4X and 12 enclosed starters. Adding or changing these kits does not affect the UL listing in most instances.

The transformer kit consists of:

- Control transformer
- Two primary and one secondary fuse
- Wires
- Mounting instruction publication

For Non-combination Starters

These kits may be used for transformer voltage conversion on Freedom NEMA starters furnished from the factory with control transformers installed. Non-combination starters with CPTs factory installed are Class ECN07, ECA07, ECE07 and ECE11. These kits may also be installed in oversize enclosures that have been designed to accept transformers.

Combination Starters

Most combination starters have space for standard size (and 100 VA extra capacity) control power transformers. The panels are pre-drilled for mounting.

UL/CSA

UL Listed — File Number E10156, Guide XPTO.

Table 16-43. Standard Transformer Sizes ①

Size	VA Capacity		
	Freedom	Vacuum	Advantage
0	50	—	—
1, 2	100	—	100
3	150	—	100
4	200	100	100
5	200	150	250
6	250	350	250

① Non-reversing, single contactor only.

When Ordering Specify

- Catalog Number

Table 16-44. Control Transformer Kits

Continuous VA	Primary 208/277V Secondary 120V, 60 Hz	Primary 240/480V, 60 Hz Secondary 220/440V, 50 Hz Secondary 120V, 60 Hz 110V, 50 Hz	Primary 380V Secondary 110V, 50 Hz	Primary 600V, 60 Hz 550V, 50 Hz Secondary 120V, 60 Hz 110V, 50 Hz	Primary 240/480V Secondary 24V, 60 Hz
	Catalog Number	Catalog Number	Catalog Number	Catalog Number	Catalog Number
50	C341AE	C341AC	C341AL	C341AD	C341AS
75	C341BE	C341BC	C341BL	C341BD	C341BS
100	C341CE	C341CC	C341CL	C341CD	C341CS
150	C341DE	C341DC	C341DL	C341DD	C341DS
200	C341EE	C341EC	C341EL	C341ED	C341ES
250	C341FE	C341FC	C341FL	C341FD	C341FS
300	C341GE	C341GC	C341GL	C341GD	C341GS
350	C341HE	C341HC	C341HL	C341HD	C341HS
500	C341JE	C341JC	C341JL	C341JD	C341JS

Table 16-45. Approximate Dimensions and Shipping Weights

Continuous VA	Dimensions in Inches (mm)						Ship Wt. Lbs. (kg)
	Wide A	High B	Deep C	Mounting			
				D	E	Slots	
50	3.00 (76.2)	3.00 (76.2)	2.56 (65.0)	2.00 (50.8)	2.50 (63.5)	.203 x .375 (5.2 x 9.5)	3.0 (1.4)
75	3.50 (88.9)	3.00 (76.2)	2.56 (65.0)	2.50 (63.5)	2.50 (63.5)	.203 x .375 (5.2 x 9.5)	4.3 (2.0)
100	3.38 (85.9)	3.38 (85.9)	2.88 (73.2)	2.38 (60.5)	2.81 (71.4)	.203 x .375 (5.2 x 9.5)	4.6 (2.1)
150	4.00 (101.6)	3.75 (95.3)	3.18 (80.8)	2.88 (73.2)	3.12 (79.2)	.203 x .375 (5.2 x 9.5)	7.0 (3.2)
200	4.00 (101.6)	4.50 (114.3)	3.81 (96.8)	2.50 (63.5)	3.75 (95.3)	.203 x .375 (5.2 x 9.5)	7.7 (3.5)
250	4.38 (111.3)	4.50 (114.3)	3.81 (96.8)	2.88 (73.2)	3.75 (95.3)	.203 x .375 (5.2 x 9.5)	10.0 (4.5)
300	4.75 (120.7)	4.50 (114.3)	3.81 (96.8)	3.25 (82.6)	3.75 (95.3)	.203 x .375 (5.2 x 9.5)	13.0 (5.9)
350	5.25 (133.4)	4.50 (114.3)	3.81 (96.8)	3.75 (95.3)	3.75 (95.3)	.203 x .375 (5.2 x 9.5)	14.0 (6.4)
500	5.50 (139.7)	5.25 (133.4)	4.75 (120.7)	4.25 (108.0)	4.38 (111.3)	.312 x .688 (7.9 x 17.5)	18.0 (8.2)

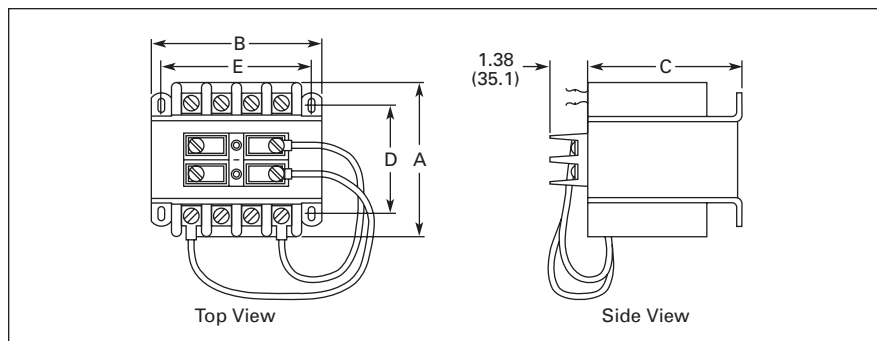

Figure 16-9. Open Type — 50 VA – 500 VA with Fuse Block

Advantage NEMA

DeviceNet™ Communications
Module

DeviceNet Module

The DeviceNet Communications module (Catalog Number WPONIDNA) is designed to plug into the Advantage with the attached cable and plug. The module can be snapped onto the top or bottom of the Advantage unit. It can also be mounted separately using the mounting plate assembly (Catalog Number WPONIBASE). The module provides DeviceNet users with the ability to control and monitor the functions of the Advantage system at 125, 250 or 500 kbaud. A connector is provided so that a HAND/OFF/AUTO hard contact may be used to selectively enable or disable the output of the control functions from the module without affecting its ability to monitor. A "Feedback" input is provided so that the state of an auxiliary contact may be read over the DeviceNet network.

Three bicolor LEDs indicate:

- DeviceNet address
- Network status (including connected, not connected, not powered)
- Module status (including normal operation, minor fault, needs commissioning)

Table 16-46. DeviceNet Interface

Description	Catalog Number
DeviceNet Interface Module	WPONIDNA
Mounting Plate Assembly	WPONIBASE

Note: See *Cutler-Hammer Control Catalog* for WPONI Network Interface.

Type W Auxiliary Contact Modules

- Provides four separate contact sets which wire vertically and are color coded; black designates NC and silver designated NO.
- Up to two auxiliary contact modules can be mounted for a total of up to eight contact sets.
- Provides circuit isolation (no polarity restrictions) and single break bifurcated contacts.
- Common design fits all Sizes 1 – 6.

Table 16-47. Ratings

Voltage	Make	Break
NEMA A600 — 120 – 600V AC	7200 VA	720 VA
NEMA Q300 — 125 – 300V DC	69 VA	69 VA

Table 16-48. Auxiliary Contact Modules

Description	Catalog Number
2NO, 2NC	W22
3NO, 1NC	W31
4NO	W40
4NC	W04
1NO, 3NC	W13
1NO, 1NC and 2 Tie Points	W11T

Transformer Pilot Light Kits

Table 16-50. Transformer Pilot Light Kits

Voltage	Color	Legend Plate	Catalog Number	Replacement Part
120	Red	RUN	PLK1R	99-3590-1
240	Red	RUN	PLK2R	99-3590-3
480	Red	RUN	PLK4R	99-3590-6
600	Green	OFF	PLK1G	99-3590-8

Bell Alarm Module

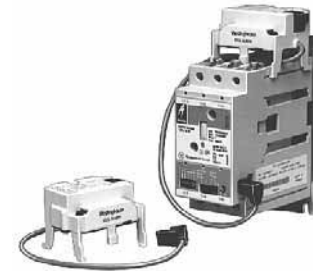

Bell Alarm Module

- Simple snap-on mounting
- Isolated NO and NC contacts (1 each)
- Plugs into Reset port
- Remote electrical Reset wired to Catalog Number WBELL module

Table 16-49. Ratings

Form C Contact Ratings Maximum Amperes — 120V AC		Catalog Number
Make	Break	
2880 VA	480 VA	WBELL
Continuous Current Rating: 5A		

Advantage NEMA

OL Selection DIP Switch Window

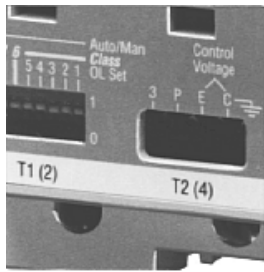

DIP Switch Window

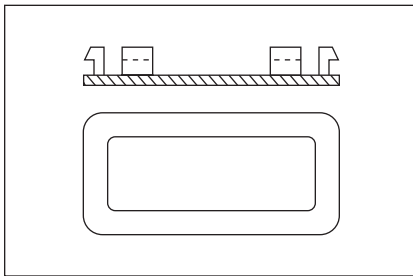

Figure 16-10. DIP Switch Window

- Simple snap-in installation
- Allows clear visibility of DIP switches
- Prevents unwanted tampering of DIP switch settings
- Once in must be pried out from rear
- One window supplied with each starter

Table 16-51. DIP Switch Window

Description	Catalog Number
DIP Switch Window, (Must order in packages of 10)	WDIPSW10

DIN Rail Adapter Kit

- Provides snap-on mounting on 35 mm DIN rail
- For use with Sizes 1 and 2 non-reversing contactors and starters

Table 16-52. DIN Rail Adapter Kit

Description	Catalog Number
DIN Rail Adapter Kit	WDIN

Internal Trip Indicator



Internal Trip Indicator

- Overload condition indication — indicated by blinking light
- Trip condition — indicated by solid light

Table 16-53. Trip Indicator

Description	Catalog Number
Internal Trip Indicator	WLED

Competitive Baseplate Kit

- Allows for direct retrofit of competitive non-reversing starters
- Eliminates the need for re-drilling and tapping of mounting holes
- Simple selection of competitive footprints

Table 16-54. Baseplate Kit

Description	Catalog Number
Sizes 1 and 2	WBASE12
Sizes 3 and 4	WBASE34

Remote Reset and Trip Indicator Pushbutton



FWD/REV/OFF/AUTO Control

- OL condition indication
- Trip indication — OL phase-loss/unbalance and ground fault
- OL reset capability
- 10250T — for 30 mm mounting
- NEMA 4 oiltight rated

- Mount remotely up to 6 ft. away
- Unit completely assembled including legend plate
- Available also in reset-only form — no trip indication provided

Table 16-55. Remote Pushbuttons

Description	Catalog Number
Reset with Trip Indication 2 ft. Cable 6 ft. Cable 15 ft. Cable	WRSTL24 WRSTL72 WRSTL180
Reset Only 2 ft. Cable 6 ft. Cable 15 ft. Cable	WRST24 WRST72 WRST180
Conversion Kit Reset Only to Reset with Trip Indication	WRLTT
6 ft. Cable Only 15 ft. Cable Only LED Replacement Bulb	WRC72 WRC180 WRLT

Advantage NEMA

Full Voltage Pushbutton
Control Module

Metering Module

Eaton's Cutler-Hammer® Advantage Control Modules (ACMs) provide a cost-effective alternative to pushbuttons, selector switches, indicating lights, reset mechanisms, bell alarms and panel meters when used with the Advantage product line. Typical input/output control functions provided by panel mounted devices are conveniently packaged in a series of modules depending on application and complexity.

Sixteen styles cover applications ranging from:

- Full voltage non-reversing
- Full voltage reversing
- Full voltage multispeed
- Reduced voltage
- DeviceNet compatible

Modules exist for each application to provide the functions of:

- Status only
 - Indicating lights
 - Reset
- Status, START/STOP and RESET
- Status, HOA and RESET
- Status, START/STOP/HOA and RESET

An additional Metering Module replaces conventional ammeters (three-phase), replaces reset mechanisms and displays trip cause and data, control voltage and status.

This Metering Module can be used independently or in conjunction with any of the ACMs. An extra plug connection is available on the rear of each ACM to accept the Metering Module input.

The ACM family has been designed to save:

- Panel space (versus conventional pushbuttons, selector switches and indicating lights)
- Mounting and assembly labor
- Wiring and installation time

Regardless of the configuration, installation requires mounting only one 2.25 x 3.5 inch module, substantially reducing space requirements. Fitting a standard Greenlee punch and die set, Greenlee #60071, installation is accomplished with only two screws.

ACMs provide savings in wiring costs as well. Regardless of the complexity of the application, wiring is reduced to a single plug-in cable, see photo at left.

Communication is not restricted by use of the Advantage Control Modules. An extra plug connection is available on the rear of the ACM or Metering Module to allow a WPONIDNA or WPOINI Communications module to be plugged in.

Full Voltage and Reduced Voltage
Control Modules

Status Only

- 4 LEDs indicate that the motor is OFF, Running, Tripped or in Alarm mode (motor current is above the trip current setting)
- Includes RESET button

START/STOP

- Motor START/STOP controlled by START and STOP buttons
- Includes all features of Status Only module

HOA Selector Switch with
START/STOP

- In HAND mode, motor will start and stop in response to START/STOP pushbuttons
- In AUTO mode, motor will run in response to remote signal
- Includes all features of Status Only module

ON/OFF/AUTO Selector Switch

- Motor will run in ON mode and not in the OFF mode
- In AUTO mode the motor will run in response to a remote signal
- Includes all features of Status Only module

Reduced Voltage Control Modules

The four reduced voltage pushbutton control modules provide control using two to four starters and/or contactors. The faceplates are identical to the full voltage modules, and the pushbuttons all perform the same functions. The module is programmed for the type of reduced voltage starter which sets the sequence of contact open and closing.

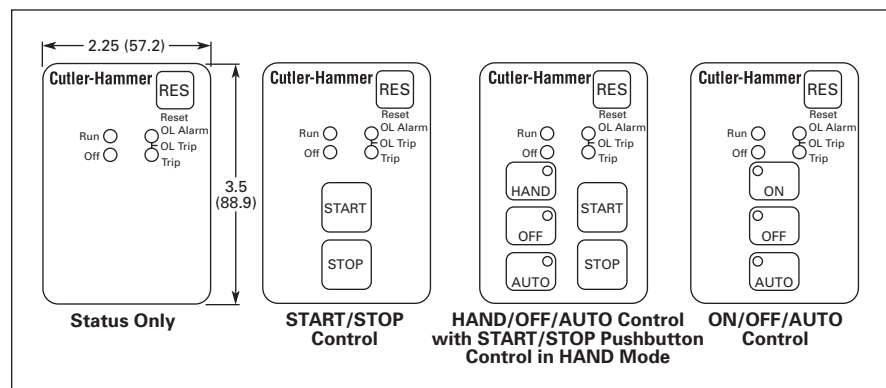

Figure 16-11. Full Voltage and Reduced Voltage Control Modules

**Reversing and 2-Speed
Pushbutton Modules**

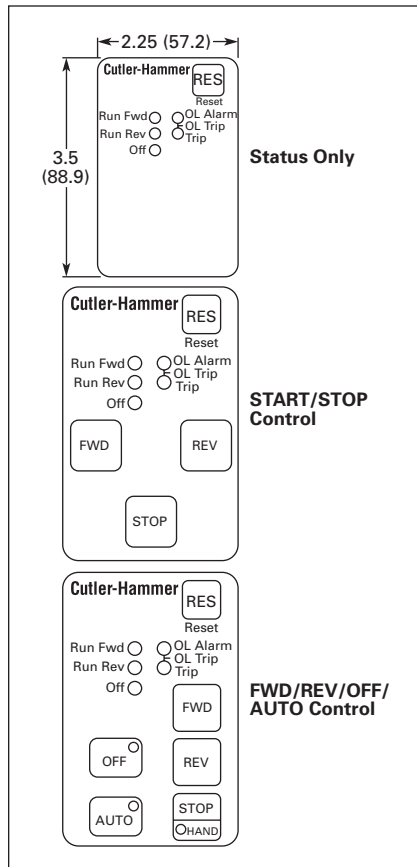

Figure 16-12. Reversing and 2-Speed Pushbutton Module

ACM Specifications

- Input supply requirements: 120V AC (supplied by the Advantage motor controller)
- Max. distance from Advantage motor controller: 6 ft. (1.83m)
- Operating frequency: 50 or 60 Hz
- Operating temperature: -20° to 70°C
- Storage temperature: -20° to 85°C
- Humidity: 0 to 95%, non-condensing
- Remote input wire size: 18 – 14 AWG
- Maximum distance between remote pushbuttons and ACM: 200 ft. (60.9m)
- Cutout dimensions: 2.25 x 3.5 inches (57.2 x 88.9 mm) (see above). The cutout can be made using a Greenlee rectangular punch #600710
- Enclosure type: Type 1 or 12, when properly installed

Status Only

- 5 LEDs which indicate that the motor is OFF, running forward (FAST), running reverse (SLOW), tripped or in alarm mode
- Includes RESET button

FORWARD (FAST)/REVERSE (SLOW)/STOP

- Pushbuttons control whether motor is running forward (FAST), running reverse (SLOW) or stopped
- Includes all features of Status Only module

FWD/REV/OFF/AUTO

- In AUTO mode, motor is running forward (FAST), running reverse (SLOW) or OFF in response to a remote signal
- All features of FORWARD/REVERSE/STOP module

Note: For 2-speed modules, FAST replaces FWD and SLOW replaces REV.

Metering Module

The Advantage Metering Module monitors status of a motor along with any of the pushbutton modules. It may be plugged into the pushbutton control module, and communicates to the starter through it, or plugged directly into the starter when a pushbutton control module is not used.

The four digit display will show the current in each phase, control voltage or cause of trip. The STEP button may be pressed to step through these values, and the five LEDs will indicate which value is being displayed. It is also equipped with a reset button and Trip Lockout LED.

Table 16-56. Control Modules/Accessories

Description	Catalog Number
Full Voltage Status Only with Reset START/STOP START/STOP/HOA ON/OFF/AUTO LOCAL/OFF/REMOTE with Lockable ACM ① LOCAL/OFF/REMOTE with Network Health ①	WPBFV1 WPBFV2 WPBFV3 WPBFV4 WPBFV5 ① WPBFV7 ①
Reversing Status Only with Reset FWD/REV/STOP FWD/REV/STOP/HOA	WPBR1 WPBR2 WPBR3
2-Speed Status Only with Reset FAST/SLOW/STOP FAST/SLOW/STOP/HOA	WPB2S1 WPB2S2 WPB2S3
Reduced Voltage Status Only with Reset START/STOP START/STOP/HOA ON/OFF/AUTO	WPBRV1 WPBRV2 WPBRV3 WPBRV4
Metering Module 10 ft. Interconnect Cable (3m) 6 ft. Interconnect Cable (1.8m) 3 ft. Interconnect Cable (.9m) 1 ft. Interconnect Jumper (.3m)	WMETER WACM10 WACM6 WACM3 WACM1

① The WPBFV5 and WPBFV7 are DeviceNet® only. They can only be used when an active network is connected.

A200 NEMA

A200 NEMA

Factory Modifications

Table 16-57. A200 Factory Modifications

Modifications	Description	Catalog Number Suffix	NEMA Size									
			00 – 1	2	3	4	5	6	7	8	9	
Control Circuit	1 Extra Auxiliary Contact (1NO-1NC) Non-reversing, Reversing, 2-Speed Unwired	J1	✓	✓	✓	✓	✓	✓	✓	✓	✓	✓
	2 Extra Auxiliary Contact Non-reversing, Reversing, 2-Speed Unwired	J2	✓	✓	✓	✓	✓	✓	✓	✓	✓	✓
	3 Extra Auxiliary Contact Non-reversing, Unwired	J3	✓	✓	✓	✓						
	4 Extra Auxiliary Contact Non-reversing, Unwired	J4	✓	✓	✓	✓						
	Wired for Separate Control (NC)	C										
	Omit Control Wiring (NC)	X	✓	✓	✓	✓	✓	✓	✓	✓	✓	✓
Overload Relays (Substitutions)	Ambient Compensated with Auto Reset (NC)	D										
	Fast Trip — Ambient Compensated (Specify Motor FLA)	D7	✓	✓	✓	✓	✓	✓				
	Overload Relay Alarm Contact (NO) per overload	E	✓	✓	✓	✓	✓	✓				

Type J Auxiliary Contact



Type J Auxiliary Contact

- Capable of being field mounted in a contactor or starter (Classes A200, A900 Sizes 00 – 6, V200, V201 vacuum and definite purpose controllers).

- Provides two separate electrical contact sets which wire vertically and are color coded; black designates NC and silver designates NO. Please note that the vertical wiring is contrary to the horizontal wiring of the L-56 auxiliary contacts.
- Designed to fit within dimensions of starter; no additional panel space is required.
- Provides circuit isolation (no polarity restrictions) and single break bifurcated contacts.

Table 16-58. Auxiliary Contact Ratings

Voltage	Make	Break
NEMA A600		
120 – 600V AC	7200 VA	720 VA
72 – 120V AC	60A	720 VA
28 – 72V AC	60 VA	10A
NEMA R300		
28 – 300V DC	28 VA	28 VA

Table 16-59. Auxiliary Contact Types

Contact Type	Max.	Catalog Number
1NO and 1NC	4	J11
2NC	4	J02
2NO	4	J20
1 Coil Clearing NC and 1NO	4	J1C

Heater Selection

General Information on Heater Coil Selection

For maximum motor protection and compliance with Article 430-32 of the National Electrical Code, select heater coils from the tables in this section on the basis of motor nameplate full load current.

When the full load current is unknown, selection may be made on the basis of average full load currents.

Caution — The average ratings could be high or low for a specific motor and therefore selection on this basis always involves risk. For fully reliable motor protection, select heater coils on the basis of full load current rating as shown on the motor nameplate.

Heater coils are rated to protect 40°C rise motors, and open and drip-proof motors having a **service factor of 1.15** where the motor and the controller are at the same ambient temperature.

For other conditions:

1. For 50°C, 55°C, 75°C rise motors and **enclosed motors having a service factor of 1.0, select one size smaller coil.**
2. Ambient temperature of controller lower than motor by 26°C (47°F), use one size smaller coil.
3. Ambient temperature of controller higher than motor by 26°C (47°F), use one size larger coil.

Ultimate tripping current of heater coils is approximately 1.25 times the minimum current rating listed in the tables.

Table 16-60. Heater Selection — Type A and B Overload Relays, Sizes 3 and 4

Size Starter	Ambient Compensated Enclosed Starters	Non-compensating Enclosed Starters	Heater (One Heater per Catalog Number)	
	All Applications		Catalog Number	
	Full Load Current of Motor Amps			
For Size 4 Starters	12.8 – 14.1	11.9 – 13.0	FH68	
	14.2 – 15.5	13.1 – 14.3	FH69	
	15.6 – 17.1	14.4 – 15.9	FH70	
	17.2 – 18.9	16.0 – 17.4	FH71	
	19.0 – 20.8	17.5 – 19.1	FH72	
	For Size 3 Starters	20.9 – 22.9	19.2 – 21.1	FH73
		23.0 – 25.2	21.2 – 23.2	FH74
		25.3 – 27.8	23.3 – 25.6	FH75
		27.9 – 30.6	25.7 – 28.1	FH76
		30.7 – 33.5	28.2 – 30.8	FH77
33.6 – 37.5		30.9 – 34.5	FH78	
37.6 – 41.5		34.6 – 38.2	FH79	
For Size 4 Starters	41.6 – 56.3	38.3 – 42.6	FH80	
	46.4 – 50	42.7 – 46	FH81	
	51 – 55	47 – 51	FH82	
	56 – 61	52 – 56	FH83	
	62 – 66	57 – 61	FH84	
	67 – 73	62 – 67	FH85	
	74 – 78	68 – 72	FH86	
	79 – 84	73 – 77	FH87	
	85 – 92	78 – 84	FH88	
	93 – 101	85 – 91	FH89	
For Size 4 Starters	102 – 110	92 – 99	FH90	
	111 – 122	100 – 110	FH91	
	123 – 129	111 – 122	FH92	
	130 – 133	123 – 128	FH93	
	—	129 – 133	FH94	

Table 16-61. Heater Selection — Type A and B Overload Relays, Sizes 5 and 6

Compensated Overload Relay		Heater (One Heater per Catalog Number)
Open Starter	Enclosed Starter	
Full Load Current of Motor (Amps)		Catalog Number
Size 5 (with 300/5 Current Transformers)		
—	—	FH23
118 – 129	118 – 129	FH24
130 – 141	130 – 141	FH25
142 – 155	142 – 155	FH26
156 – 170	156 – 170	FH27
171 – 187	171 – 187	FH28
188 – 205	188 – 205	FH29
206 – 224	206 – 224	FH30
225 – 244	225 – 244	FH31
245 – 263	245 – 263	FH32
264 – 292	264 – 292	FH33
293 – 300	—	FH34
Size 6 (with 600/5 Current Transformers)		
—	—	FH23
236 – 259	236 – 259	FH24
260 – 283	260 – 283	FH25
284 – 310	284 – 310	FH26
311 – 340	311 – 340	FH27
341 – 374	341 – 374	FH28
375 – 411	375 – 411	FH29
412 – 448	412 – 448	FH30
449 – 489	449 – 489	FH31
490 – 527	490 – 527	FH32
528 – 585	528 – 540	FH33
586 – 600	—	FH34

Note: Size 7 and Larger — Advise Full Load Current.

A200 NEMA

Table 16-62. Heater Selection — Type A and B Overload Relays, Sizes 0, 1 and 2

Size Starter	Non-compensated Open Starters and Ambient Comp. Open and Enclosed Starters		Heater (One Heater per Catalog Number)	Non-compensating Enclosed Starters		Heater	
	Block Type Overload Using 3 Heaters	Single-Pole Type Overload	Catalog Number	Block Type Overload Using 3 Heaters	Single-Pole Type Overload	Catalog Number	
	Full Load Current of Motor (Amps)						
For Size 2 Starters	.25 – .27	.29 – .31	FH03	.24 – .25	.28 – .30	FH03	
	.28 – .31	.32 – .35	FH04	.26 – .28	.31 – .34	FH04	
	.32 – .34	.36 – .39	FH05	.29 – .31	.35 – .37	FH05	
	.35 – .38	.40 – .43	FH06	.32 – .35	.38 – .42	FH06	
	.39 – .42	.44 – .48	FH07	.36 – .39	.43 – .47	FH07	
	For Size 1 Starters	.43 – .46	.49 – .53	FH08	.40 – .43	.48 – .52	FH08
		.47 – .50	.54 – .58	FH09	.44 – .47	.53 – .56	FH09
		.51 – .55	.59 – .64	FH10	.48 – .51	.57 – .63	FH10
		.56 – .62	.65 – .71	FH11	.52 – .57	.64 – .70	FH11
		.63 – .68	.72 – .79	FH12	.58 – .63	.71 – .77	FH12
		For Size 0 Starters	.69 – .75	.80 – .87	FH13	.64 – .70	.78 – .85
	.76 – .83		.88 – .96	FH14	.71 – .77	.86 – .94	FH14
	.84 – .91		.97 – 1.06	FH15	.78 – .85	.95 – 1.03	FH15
	.92 – 1.00		1.07 – 1.16	FH16	.86 – .93	1.04 – 1.13	FH16
	1.01 – 1.11		1.17 – 1.28	FH17	.94 – 1.03	1.14 – 1.25	FH17
	1.12 – 1.22		1.29 – 1.41	FH18	1.04 – 1.13	1.26 – 1.38	FH18
	1.23 – 1.34		1.42 – 1.55	FH19	1.14 – 1.25	1.39 – 1.52	FH19
1.35 – 1.47	1.56 – 1.71	FH20	1.26 – 1.37	1.53 – 1.67	FH20		
1.48 – 1.62	1.72 – 1.87	FH21	1.38 – 1.51	1.68 – 1.83	FH21		
1.63 – 1.78	1.88 – 2.06	FH22	1.52 – 1.65	1.84 – 2.01	FH22		
For Size 2 Starters	1.79 – 1.95	2.07 – 2.26	FH23	1.66 – 1.81	2.02 – 2.21	FH23	
	1.96 – 2.15	2.27 – 2.48	FH24	1.82 – 1.99	2.22 – 2.43	FH24	
	2.16 – 2.35	2.49 – 2.72	FH25	2.00 – 2.19	2.44 – 2.66	FH25	
	2.36 – 2.58	2.73 – 2.99	FH26	2.20 – 2.39	2.67 – 2.92	FH26	
	2.59 – 2.83	3.00 – 3.28	FH27	2.40 – 2.63	2.93 – 3.21	FH27	
	2.84 – 3.11	3.29 – 3.60	FH28	2.64 – 2.89	3.22 – 3.53	FH28	
	3.12 – 3.42	3.61 – 3.95	FH29	2.90 – 3.17	3.54 – 3.87	FH29	
3.43 – 3.73	3.96 – 4.31	FH30	3.18 – 3.47	3.88 – 4.22	FH30		
3.74 – 4.07	4.32 – 4.71	FH31	3.48 – 3.79	4.23 – 4.61	FH31		
4.08 – 4.39	4.72 – 5.14	FH32	3.80 – 4.11	4.62 – 4.9	FH32		
For Size 2 Starters	4.40 – 4.87	5.15 – 5.6	FH33	4.12 – 4.55	5.0 – 5.5	FH33	
	4.88 – 5.3	5.7 – 6.2	FH34	4.56 – 5.0	5.6 – 6.0	FH34	
	5.4 – 5.9	6.3 – 6.8	FH35	5.1 – 5.5	6.1 – 6.6	FH35	
	6.0 – 6.4	6.9 – 7.5	FH36	5.6 – 5.9	6.7 – 7.3	FH36	
	6.5 – 7.1	7.6 – 8.2	FH37	6.0 – 6.6	7.4 – 8.0	FH37	
	7.2 – .78	8.3 – 9.0	FH38	6.7 – 7.2	8.1 – 8.7	FH38	
	7.9 – 8.5	9.1 – 9.9	FH39	7.3 – 7.9	8.8 – 9.7	FH39	
8.6 – 9.4	10.0 – 10.8	FH40	8.0 – 8.7	9.8 – 10.5	FH40		
9.5 – 10.3	10.9 – 11.9	FH41	8.8 – 9.5	10.6 – 11.7	FH41		
10.4 – 11.3	12.0 – 13.1	FH42	9.6 – 10.5	11.8 – 12.7	FH42		
For Size 2 Starters	11.4 – 12.4	13.2 – 14.3	FH43	10.6 – 11.5	12.8 – 14.0	FH43	
	12.5 – 13.5	14.4 – 15.7	FH44	11.6 – 12.6	14.1 – 15.3	FH44	
	13.6 – 14.9	15.8 – 17.2	FH45	12.7 – 13.8	15.4 – 16.6	FH45	
For Size 2 Starters	15.0 – 16.3	17.3 – 18.9	FH46	13.9 – 15.1	16.7 – 18.3	FH46	
	16.4 – 18.0	19.0 – 20.8	FH47	15.2 – 16.7	18.4 – 20.0	FH47	
For Size 2 Starters	18.1 – 19.8	20.9 – 22.9	FH48	16.8 – 18.3	20.1 – 21.9	FH48	
	19.9 – 21.7	23.0 – 25.2	FH49	18.4 – 20.2	22.0 – 23.9	FH49	
	21.8 – 23.9	25.3 – 27.6	FH50	20.3 – 22.2	24.0 – 26.2	FH50	
For Size 2 Starters	24.0 – 26.2	27.7 – 30.3	FH51	22.3 – 24.3	26.3 – 28.8	FH51	
	26.3 – 28.7	30.4 – 33.3	FH52	24.4 – 26.6	28.9 – 31.4	FH52	
For Size 2 Starters	28.8 – 31.4	33.4 – 36.4	FH53	26.7 – 29.1	31.5 – 34.5	FH53	
	31.5 – 34.5	36.5 – 39.9	FH54	29.2 – 32.0	34.6 – 37.9	FH54	
	34.6 – 37.9	40.0 – 43.9	FH55	32.1 – 35.2	3.80 – 41.9	FH55	
For Size 2 Starters	38.0 – 41.5		FH56	35.3 – 38.5	42.0 – 45.0	FH56	
	41.6 – 45.0		FH57	38.6 – 42.3		FH57	

A200 NEMA



SS-56 Surge Suppressor

SS-56 Surge Suppressor

- Designed to be used with magnetic motor controllers through Size 4 in 120V, 60 Hz control circuit applications where electronic equipment is used.
- Steady State Coil Volts: 120, 60 Hz, RMS
- Peak Input Volts: 169.6, 60 Hz, Max. Amplitude
- Max. Ambient Temperature: 65°C
- Nominal Limiting Volts: 270 Peak
- Nominal Rate of Volt Rise: .5 per mS

Table 16-63. Surge Suppressor ①

Type Mounting	Kit Catalog Number
Starter	SS-56

① Can be used on Sizes 5 and 6 with 120V coil. Mounting bracket required — order separately. Mounting Bracket 177C043G04.

Mechanical Interlock

- Prevents closing of one member of a reversing or multi-speed contactor until the opposite member is completely open.

Table 16-66. Mechanical Interlock

Contacting Arrangement (Number of Poles, Horizontal or Vertical)	Continuous Size	Interlock Catalog Number
3 x 3 Horizontal	0, 1	M-33-1B
4 x 4 Horizontal	0, 1	M-33-1B
5 x 3 Horizontal	0, 1	M-33-1B
All Pole Combination, Vertical	0, 1	M-34-1A
3 x 3 Horizontal Reversing	2	M-33-2B
3 x 3 Vertical Reversing	2	M-34-2A
5 x 3 Horizontal	2	M-35-2A
4 x 4 Horizontal	2	M-36-2A
All Pole Combination Horizontal	3, 4	M-33-3B
All Pole Combination Vertical	3, 4	M-34-3

F-56 Fuse Block

- Facilitates installation of fuses (15A, 600V max.) in control circuits.
- Utilizes Bussman type KTK fuses, or equivalent.
- Mounts in same cavity as Type J auxiliary contact.
- No tools or mounting hardware needed.
- Fuse not included.

Table 16-64. Fuse Block

Mounting	Kit Catalog Number
Starter Panel	F56 F56-P

R-56 Interposing Relay

The R-56AA interposing relay is a low energy solid-state device with a single NO solid-state contact. It can be used as a 120V AC control relay, and will operate on as little as 40V AC input. Is useful in applications requiring long control wiring runs where excessive voltage drop would prevent the contactor or relay from energizing. Will operate a Size 4 contactor from 10,000 feet using 18 AWG wire.

Table 16-65. Interposing Relay

Type Mounting	Kit Catalog Number
Starter or Panel	R56-AA

- Lever type mechanism assures positive action.
- Can be factory assembled or field mounted on A200 and A900 starters and contactors.

B3NO Bell Alarm Contact

- Isolated Normally Open Bell Alarm Contact.
- Mounts in Type B block-type overload relay.

Table 16-67. Bell Alarm Contact

Kit Catalog Number
B3NO-2 B3NO-4 ②

② For Size 3 and 4.

Table 16-68. Control Contact Ratings (B600)

AC Volts	Maximum Amperes	
	Make	Break
24 – 120	30	3.00
121 – 600	3600 VA	360 VA
Continuous Current Rating: 5A		

Overload Relay Reset Extension

- Used to adjust overload reset rod depth of Class A200 Model J starters and current design overload relays to same dimensions as obsolete B200 starters and overloads identified by suffix **B**, i.e., BA13B.

When replacing obsolete B200 device with Class A200 starter and Type B overload, order Style 6710C11H03. No charge.

When replacing obsolete B200 device with Class A200 starter and Type A overload, order Style 1490C15H10. No charge.

Power Pole Kit

- Adds 1NO or 1NC power pole to Size 00 – 1 A201 Class contactors.
- Factory installed or field mountable in load side auxiliary cavities.
- 600V AC.
- Continuous current rating of 18A for Size 0, 27A for Size 1.

Table 16-69. Power Pole Kit ③

Continuous Current Rating	Kit Size	Kit Catalog Number
Normally Open		
18	0	PN0-0
27	1	PN0-1
Normally Closed		
18	0	PNC-0
27	1	PNC-1

③ Do not use with DC operated contactors.

A200 NEMA

Replacement Auxiliary Contacts

Table 16-70. Replacement Auxiliary Contacts

Contactor Size	Contact Arrangement	Aux. Elect. Contact	
		Catalog Number	Style Number
5, 6	1NO + 1NC	J11	9084A17G01
	2NO	J20	9084A17G02
	2NC	J02	9084A17G03
7, 8	1NO	—	578D461G01
	1NC	—	578D461G03
9	1NO + 1NC	—	843D943G04
	2NO	—	843D943G05
	2NC	—	843D943G06

Extra Auxiliary Contact Kits

All starters include an auxiliary contact with 1NO and 1NC contact. These kits include an auxiliary contact with contacts as shown, plus operating arm and mounting bracket when required.

Table 16-71. Extra Auxiliary Contact Kits

Contactor Size	Contact Arrangement	Style Number
5, 6	1NO + 1NC	3463D94G18
	2NO	3463D94G04
	2NC	3463D94G19
7, 8 ^①	2NO	818D498G06
	1NO	818D498G04

^① Size 7 and larger use DC coils as standard.

DC Coil Conversion Kits

Kits listed below include all necessary parts to convert from AC to DC control including the DC coil with built-in diode, rectifier, auxiliary interlock and all mounting hardware.

Table 16-72. DC Coil Conversion Kits

Size	Voltage	Kit Style Number
5	110-120	7864A28G01
	220-240	7864A28G02
	440-480	7864A28G03
6	110-120	7864A29G01
	220-240	7864A29G02
	440-480	7864A29G03

Mechanical Interlocks

Table 16-73. Mechanical Interlocks

Contactor Sizes	Style Numbers	
	Horizontal	Vertical
3, 4 and 5	2050A11G75	2050A11G65
5 and 5	2050A11G25	2050A11G15
5 and 6	2050A11G27	2050A11G17
6 and 6	2050A11G26	2050A11G16
6 and 7, 8	—	2050A11G55
7, 8 and 7, 8	No (Rear Conn.)	567D624G01
7, 8 and 9	No (Rear Conn.)	9944D56G06
9 and 9	No (Rear Conn.)	9944D56G01

Overload Protection

Overload Protection Size 5 Starters

Type B overload relay is a three-pole, block type, thermal ambient compensated device with manual reset mounted integrally. Current transformers are enclosed in a protective case and integrally mounted to save panel space. Standard ratio is 300:5.

Overload Protection Size 6 Starters

Overload protection assembly consists of three current transformers, Type B three-pole block overload relay and an optional interposing relay. These parts are mounted on a panel which connects directly to the load terminal of the contactor. Current transformers are 600:5 ratio as standard.

If automatic reset is required, the Type A, three-pole block, ambient compensated relay is available upon request.

Overload Relay Kits

Each kit includes three current transformers (standard ratio) and one Type B, three-pole block overload relay, ambient compensated with manual reset.

Table 16-74. Overload Relay Kits

Kit Size	Kit Part Number
5	2057A34G01
6	6379D80G10

Table 16-75. Replacement Terminal Lugs ^②

Contactor Size	Cable Size	Terminals		Kit Style Number
		Qty. in Kit	Qty. Req'd. per Pole	
5	1-500 MCM	6	2	2119A76G01
6	2-500 MCM	6	2	7858A96G01
7	4-500 MCM	12	4	7858A96G02
8	4-500 MCM	12	4	7858A96G03

^② All mounting hardware is included in kit.

XTIEC

XTIEC

Auxiliary Contacts

Front mounted snap-on auxiliary contacts for **XT** contactors are available with screw or spring cage terminals in a variety of contact configurations.

Notes:

The 7 – 32A XTCE Contactors have positively driven contacts between the integrated auxiliary contact and the auxiliary contact module as well as within the auxiliary contact modules.

The 40 – 65A XTCE Contactors have positively driven contacts within the auxiliary

contact module. 6 auxiliary contacts are possible with a combination of side mounted and front mount auxiliary contacts.

Frame B – C contactors with 1NC built-in auxiliary are mirror contacts (XTCE...B01_ – XTCE...C01_).

Table 16-76. XTCE and XTCS Auxiliary Contact Overview

Frame	A	B	C	D	F	G	L – R
Catalog Numbers	XTMC6A... – XTMC9A...	XTCE007B... – XTCE015B...	XTCE018C... – XTCE032C...	XTCE040D00_ – XTCE065D00_	XTCE080F00_ – XTCE095F00_	XTCE115G00_ – XTCE150G00_	XTCE185L22_ – XTCEC20R22_ ①
Contact Width	45 mm	45 mm	45 mm	55 mm	90 mm	90 mm	Various
Built-In Auxiliary	1NO or 1NC	1NO or 1NC	1NO or 1NC	—	—	—	2NO-2NC
Contact Sequence							
Front (Top) Mount Auxiliary	<p>2-Pole & 4-Pole (Screw or Spring Cage):</p>	<p>Standard 2-Pole & 4-Pole Versions (Screw or Spring Cage):</p> <p>Tall Version (Screw Only):</p>		<p>2-Pole (Screw Only):</p> <p>4-Pole (Screw or Spring Cage):</p>			N/A
Side Mount Auxiliary	N/A	N/A	<p>2-Pole (Screw Only):</p>	<p>2-Pole (Screw or Spring Cage):</p>			

① Frame L – R auxiliary contacts also apply to XTCS185L... – XTCS500M... contactors.

XTIEC

Table 16-77. Auxiliary Contacts

	Conventional Thermal Current, Open at 60°C $I_{th} = I_e$, AC-1 in Amps	Poles	Contact Configuration	Circuit Symbol	Pkg. Qty.	Screw Terminals	Spring Cage Terminals
						Catalog Number	Catalog Number
Frame B – C — Front (Top) Mount							
	16	2	2NO		5	XTCEXFAC20	XTCEXFACC20
	16	2	1NO-1NC		5	XTCEXFAC11	XTCEXFACC11
	16	2	2NC		5	XTCEXFAC02	XTCEXFACC02
	16	2	1NO _E -1NC _L		5	XTCEXFALC11 ①	XTCEXFALCC11 ①
	16	2	1NO-1NC		5	XTCEXFDC11 ②	XTCEXFDC11 ②
	16	2	2NC		5	XTCEXFCC02 ②	XTCEXFCC02 ②
	16	4	4NO		5	XTCEXFAC40	XTCEXFACC40
	16	4	3NO-1NC		5	XTCEXFAC31	XTCEXFACC31
	16	4	2NO-2NC		5	XTCEXFAC22	XTCEXFACC22
	16	4	1NO-3NC		5	XTCEXFAC13	XTCEXFACC13
	16	4	4NC		5	XTCEXFAC04	XTCEXFACC04
	16	4	1NO _E -1NC _L		5	XTCEXFCLC22 ①	XTCEXFCLCC22 ①
	16	4	2NO-2NC		5	XTCEXFCC22 ②	XTCEXFCC22 ②

① 1 early-make contact (1NO_E), 1 late-break contact (1NC_L).

② To avoid duplicate terminal numbers in contact sequence, these auxiliary contacts should only be used with contactors having a built-in 1NO contact (XTCE...B10_, XTCE...C10_).

XTIEC

Table 16-77. Auxiliary Contacts (Continued)

	Conventional Thermal Current, Open at 60°C I _{th} = I _e , AC-1 in Amps	Poles	Contact Configuration	Circuit Symbol	Pkg. Qty.	Screw Terminals	Spring Cage Terminals
						Catalog Number	Catalog Number
Frame B – C — Front (Top) Mount — Tall Version ②							
	16	2	2NO		5	XTCEXFATC20	—
	16	2	1NO-1NC		5	XTCEXFATC11	—
	16	2	2NC		5	XTCEXFATC02	—
	16	4	2NO-2NC		5	XTCEXFATC22	—
Frame C — Side Mount							
	10	2	1NO-1NC		1	XTCEXSCC11 ③	—
Frame D – G							
	16	2	2NO		5	XTCEXFBG20	—
	16	2	1NO-1NC		5	XTCEXFAG11	—
	16	2	1NO-1NC		5	XTCEXFBG11	—
	16	2	2NC		5	XTCEXFBG02	—
	16	4	4NO-0NC		5	XTCEXFBG40	XTCEXFBGC40
	16	4	3NO-1NC		5	XTCEXFBG31	XTCEXFBGC31
	16	4	2NO-2NC		5	XTCEXFBG22	XTCEXFBGC22
	16	4	2NO-2NC		5	XTCEXFAG22	XTCEXFAGC22
	16	4	1NO-3NC		5	XTCEXFBG13	XTCEXFBGC13
	16	4	0NO-4NC		5	XTCEXFBG04	XTCEXFBGC04
	16	4	1NO _E -1NC _L		5	XTCEXFBLG22 ①	XTCEXFBLC22 ①

① 1 early-make contact (1NO_E), 1 late-break contact (1NC_L).

② Front (Top) Mount Tall Version is for use with Frame B Electrical Wire Bridges and Link Kits and Toolless Plug Combination Connection Kits: XTCEXRLB, XTCEXSDLB, XTPAXTPCB, XTPAXTPCRB, XTPAX.

③ Can be mounted to the left side of contactor only. Cannot be used in combination with front (top) mount auxiliary contacts or mechanical interlocks.

Notes:

■ Interlocked opposing contacts, to IEC/EN 60947-5-1 Annex L (positively driven), within the auxiliary contact modules (not NO (early make) and NC (late break) contacts) and for the built-in auxiliary contacts of the XTCE007B... – XTCE032C....

■ Auxiliary break contact can be used as mirror contact to IEC/EN 60947-4-1 Annex F (not NC (late break) contact).

■ No auxiliary contacts can be fitted between two contactors.

XTIEC

Table 16-78. Side Mount Auxiliary Contacts for Frame D – R, 40 – 2000A

	Conventional Free Air Thermal Current, I _{th} = I _e , AC-1 in Amps	Poles	Contact Configuration	Circuit Symbol	Pkg. Qty.	Screw Terminals	Spring Cage Terminals
						Catalog Number	Catalog Number
Frame D – R							
	10	2	1NO-1NC		1	XTCEXSBN11	XTCEXSBNC11
	10	2	1NO _E -1NC _L		1	XTCEXSBLN11 ①	—
	10	2	1NO-1NC		1	XTCEXSCN11 ②	XTCEXSCNC11 ②

- ① 1 early-make contact (1NO_E), 1 late-break contact (1NC_L).
- ② To maintain proper terminal marking, XTCEXSCN_ should not be used with Frame D contactors and only used with Frame F – G contactors in combination with XTCEXSBN_.

Table 16-79. Auxiliary Contacts Possible Combinations

Frame Size	Catalog Number	Contactor	Built-In Auxiliary	Front (Top) Mount		Side Mount	Total Auxiliary Contacts Available
				2-Pole	4-Pole	2-Pole	
A	XTMC6A... – XTMC9A...		1NO or 1NC	1	—	—	3
				—	1	—	5
						—	—
B	XTCE007B... – XTCE015B...		1NO or 1NC	1	—	—	3
				—	1	—	5
						—	—
C	XTCE018C... – XTCE032C...		1NO or 1NC	1	—	—	3
				—	1	—	5
				—	—	1	3
							—
D	XTCE040D00_ – XTCE065D00_		—	1	—	2	6
				—	1	1	6
							—
F – G	XTCE080F00_ – XTCE150G00_		—	1	—	2	6
				—	1	2	8
				—	—	4	8
							—
L – R	XTCE185L22_ – XTCEC20R22_		2NO-2NC	—	—	2	8
				—	—		—

- Notes:**
- Forced operation contact to IEC/EN 60947-5-1 Appendix L (positively driven), inside the auxiliary contact unit (not early close and late opening).
 - Auxiliary normally closed contact can be used as mirror contact to IEC/EN 60947-4-1 Appendix F (not late opening).
 - No auxiliary contacts can be fitted between two contactors.

16

XTIEC

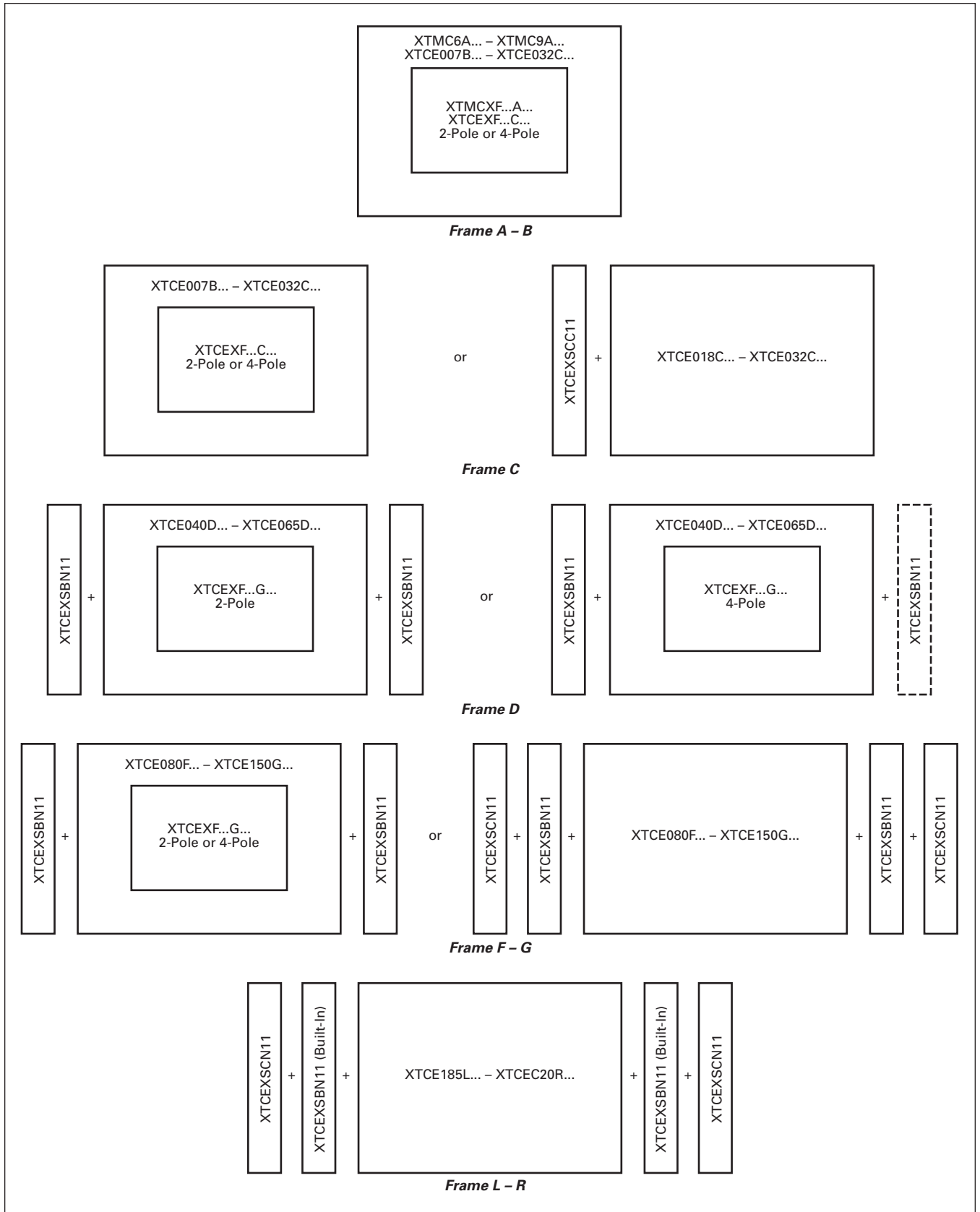

Figure 16-13. Auxiliary Contact Combinations

Enclosures

Type 1 Enclosures

Table 16-80. Type 1 Enclosures — NEMA (Freedom and /T. Type)

Starter Type	Box Number	NEMA Size AN16	Catalog Number
Non-reversing Starter	1	00 – 1	C799B11 ^{① ④}
	1	—	C799B12 ^①
	2	2	C799B13
	4	3 – 4	C799B15
	10	5	C799B17
Non-reversing Starter with Space for CPT	3	00 – 2	C799B14 ^②
	4	3 – 4	C799B15 ^③
Reversing Starter	2	00 – 0	C799B13
	3	1 – 2	C799B14
	4	3	C799B15
	9	4	C799B16
	10	5	C799B17



Type 1



Type 3R

① In order to install cover control kits for NEMA Sizes 00 – 2 and IEC Sizes A – F, the starter must be provided with a **side mounted** auxiliary contact or a separately ordered Dummy Contact Block, **C320KGSD** from **Table 16-81**, to serve as a mounting base. **Note:** NEMA Size 00 open type devices **are not** supplied as standard with side mounted auxiliaries.

② Sub panel drilled for 50 – 200 VA CPTs.

③ Enclosure drilled for 150 – 300 VA CPTs.

④ If 8 AWG wire is used with NEMA Size 1 starter, the enclosure should be changed to a Box 2 (C799B13).

Note: Box 1 will **not** accept devices with top mounted auxiliaries. Box 2 will accept NEMA Sizes 00 and 0 starters with top mounted auxiliaries.

Table 16-81. Dummy Contact Block

Application	Catalog Number
Dummy Contact Block	C320KGSD

Enclosures

Type 3R, 4X and 12 Enclosures

Table 16-82. Type 3R, 4X and 12 Enclosures — NEMA (Freedom and IT Type)

Starter Type	Box Number	NEMA Size AN16	Type 3R	Type 12	Type 4X
			Catalog Number	Catalog Number	Catalog Number
Non-reversing Starter	5	00 – 1	C799B21	C799B81	C799B41
	6	2	C799B24	C799B84	C799B43
	6	—	C799B25	C799B85	C799B44
	8	3	C799B210	C799B810	C799B47
	8	—	C799B212	C799B812	C799B49
	8	4	C799B211	C799B811	C799B48
Non-reversing Starter with Space for CPT	10	5	C799B218	C799B818	C799B413
	6	00 – 2	C799B24	C799B84	C799B43
	6	—	C799B25	C799B85	C799B44
	8	3	C799B210	C799B810	C799B47
	8	—	C799B212	C799B812	C799B49
Reversing Starter	8	4	C799B211	C799B811	C799B48
	10	5	C799B218	C799B818	C799B413
	6	00 – 2	C799B24	C799B84	C799B43
	6	—	C799B25	C799B85	C799B44
	8	3	C799B210	C799B810	C799B47
Multispeed	8	—	C799B212	C799B812	C799B49
	9	4	C799B215	C799B815	C799B411
	10	5	C799B218	C799B818	C799B413
	7 ①	0 – 2	C799B223	C799B823	C799B417

① Blank cover provided.

Table 16-83. Type 3R, 4X and 12 Enclosures — NEMA (Advantage Type) — with Hole Plugs

Starter Type	Box Number	Size	Type 3R	Type 12	Type 4X
			Catalog Number	Catalog Number	Catalog Number
Non-reversing Starter	5	1 – 2	C799B22	C799B82	C799B42
Non-reversing Starter with Space for CPT and Reversing	6	1 – 2	C799B26	C799B86	C799B45
Non-reversing Starter, Non-reversing Starter with Space for CPT, and Reversing	8	3	C799B213	C799B813	C799B410
	9	4	C799B216	C799B816	C799B412
	10	5	C799B219	C799B819	C799B414

Table 16-84. Type 3R, 4X and 12 Enclosures — NEMA (Advantage Type) — with Cutout for 1 ACM and Hole Plugs ②

Starter Type	Box Number	Size	Type 3R	Type 12
			Catalog Number	Catalog Number
Non-reversing Starter	5	1 – 2	C799B23	C799B83
Non-reversing Starter with Space for CPT and Reversing	6	1 – 2	C799B27	C799B87
Non-reversing Starter, Non-reversing Starter with Space for CPT Reversing	8	3	C799B214	C799B814
	9	4	C799B217	C799B817
	10	5	C799B220	C799B820

② All boxes have 1 ACM cutout. In addition, Box 5 has one 30 mm round hole, Boxes 6 and 7 have two; Boxes 8, 9 and 10 have three holes plugged.

Table 16-85. Enclosures — IEC (XT Type)

Starter Type	Box Number	IEC Size	Catalog Number
XT Starters, 15A and 25A, with reset	1	B – C	C799B31
XT Contactors/Starters without reset	1	B – C	C799B33
XT Contactors/Starters with reset	2	B – C – D	C799B36
XT Contactors/Starters without reset	2	B – C – D	C799B34
XT Contactors/Starters with resets	1	B – C	C799B35
XT Contactors/Starters with resets	2	B – C – D	C799B37

Lighting Contactors

Lighting Contactors

Electrically Held Base Contactor for C30CN/ECC

The C30CNE20_0 Electrically Held Base Contactor contains a 2NO power pole as standard and will allow the addition of power poles to build an Electrically Held Contactor up to 12 poles maximum. A Mechanically Held Module Kit can also be added to convert the Electrically Held Contactor into a Mechanically Held Contactor in the field.



Electrically Held Base Contactor

Table 16-86. Electrically Held Base Contactor

Power Poles	Catalog Number ①
2NO	C30CNE20_0

① When ordering, select required contactor by Catalog Number and replace the magnet coil alpha designation in the Catalog Number () with the proper Code Suffix from Table 16-87.

Table 16-87. Coil Base Voltage (Digit 9)

Voltage (Digit 9)	Code Suffix
115 – 120V 60 Hz/110V 50 Hz	A
230 – 240V 60 Hz/220V 50 Hz	B
460 – 480V 60 Hz/440V 50 Hz	C
575 – 600V 60 Hz/550V 50 Hz	D
200 – 208V 60 Hz	E
265 – 277V 60 Hz/240V 50 Hz	H
24V 60 Hz/20V 50 Hz	T
28V 60 Hz/24V 50 Hz	V
347V 60 Hz	X

Power Poles for C30CNM/ECC



Power Poles

The C30CNM contactor accepts up to a maximum 6 single- or double-pole (or combinations) power poles. These can be used to form up to:

- 12 NO poles max. when 6 double-poles are used in NO positions (1 – 6) or
- 8 NC poles max. with 4 double-poles in the NC position (1 – 4) and 4 NO poles with 2 double-poles in the 2 NO positions (5 – 6)

Table 16-88. Power Poles

Power Poles	Catalog Number
Single-Pole	C320PRP1
Double-Pole	C320PRP2

Mechanically Held Module Kits for C30CN/ECC

These kits are for converting electrically held contactors to mechanically held units. Kits include control module, latch, latch cover and auxiliary contacts plus installation instructions. Conversion kits are suitable for coil voltages of 277V and below.



Conversion Kits

Table 16-89. Mechanically Held Module Kits

Coil Volts	Control Volts	Catalog Number
2-Wire		
24 – 277V AC	110 – 120V AC	C320MH2WA0
	200 – 277V AC	C320MH2WH0
	24V AC	C320MH2WT0
	12 – 24V DC	C320MH2WT1
3-Wire		
24 – 277V AC	110 – 120V AC	C320MH3WA0
	200 – 277V AC	C320MH3WH0
	24V AC	C320MH3WT0
	12 – 24V DC	C320MH3WT1

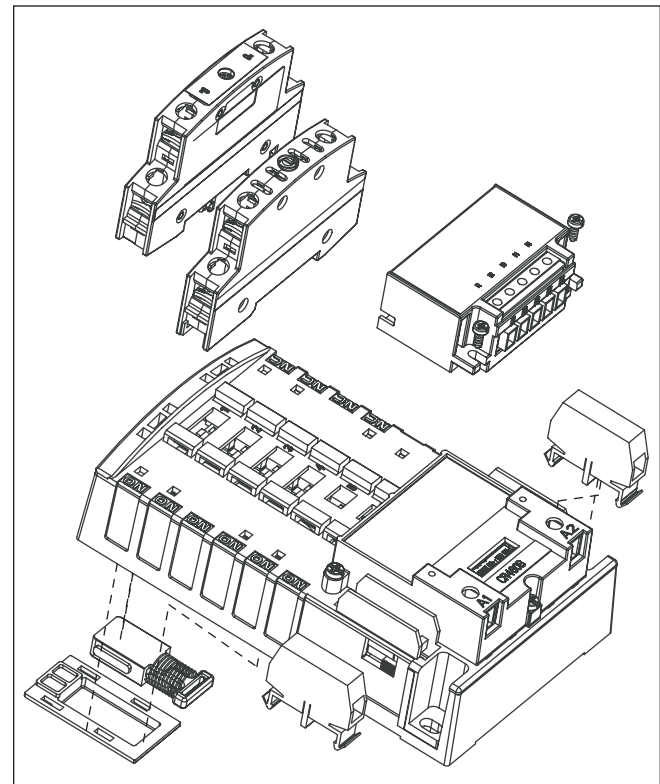

Figure 16-14. C30CNM Components — Exploded View

Lighting Contactors

Auxiliary Contacts for C30CN/ECC

A Mechanically Held Contactor with a 2-wire control module uses 1NC auxiliary contact as standard for the control wiring circuit. The Mechanically Held Contactor with a 3-wire control module uses 1NO-1NC auxiliary contacts as standard for the control wiring circuit. See **Table 16-90** for possible additional auxiliary contact configurations.

Table 16-90. Auxiliary Contact Configurations

2-Wire	3-Wire
None 1NO (single-pole) 2NO (double-pole) 1NC (double-pole) 1NO-1NC (NO single pole, NC double-pole) 2NO-1NC (double-pole)	1NC (double-pole) 1NO (double-pole) 1NO-1NC (double-pole)



Auxiliary Contacts

Table 16-91. Auxiliary Contacts

Auxiliary Block	Catalog Number
Single-Pole	C320AMH1
Double-Pole	C320AMH2

Transient Suppressor Kits for CN35/ECL

10 – 60A Contactors

These kits limit high voltage transients produced in the control circuit when power is removed from the contactor or starter coil. There are three separate suppressors for use on 24 –120V, 240V or 480V coils respectively.



Cat. No. C320TS2

These devices mount directly to the coil terminals of lighting contactors 10 – 60A.

Table 16-92. Kits for 10 – 60A

Description	Coil Voltage	Catalog Number
Transient Suppressor	24 –120V	C320TS1
	240V	C320TS2
	480V	C320TS3

100 – 300A Contactors

This device mounts on top of any side mounted auxiliary contact on lighting contactors 100 – 300A. It connects across coil terminals on any 120V contactor magnet coil.



Cat. No. C320TS2

Limits high voltage transients produced in the circuit when power is removed from the coil.

Table 16-93. Kits for 100 – 300A

Description	Coil Voltage	Catalog Number
Transient Suppressor	120V	C320AS1

Lighting Contactors

Auxiliary Contacts for CN35/ECL

CN35 Lighting Contactors include a 1NO maintaining auxiliary contact mounted on right hand side (on 10A, 2- and 3-pole devices, auxiliary contact occupies 4th power pole position — no increase in width). The 10 – 60A devices will accept additional auxiliary contacts on the top and/or sides.

Auxiliary contact blocks are designed for snap-on installation — fast, easy installation (no tools required up to 60A). All auxiliary contacts are of the bifurcated design with parallel circuit paths. This redundant path provides very high reliability. Auxiliary contacts can be snapped on the side (up to 2 circuits — per auxiliary contact) and on the top (up to 4 circuits). Auxiliary contacts for larger contactors, 100 – 400A sizes, will accept side mounted auxiliaries only and easily attach to the side of the contactor with 2 screws.

Auxiliary Contacts —
10 – 60A Contactors

Side Mounted

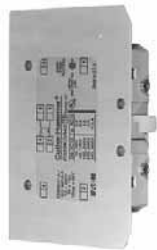

Top Mounted

Auxiliary Contacts —
100 – 400A ContactorsBase Auxiliary Contact
Cat. No. C320KGS42Auxiliary Contact
Cat. No. C320KGS22

Contact Configuration Code

This 2-digit code is found on the auxiliary contact to assist in identifying the specific contact configuration. The first digit indicates the quantity of NO contacts and the second indicates the quantity of NC contacts.

Table 16-94. Auxiliary Contacts — 10 – 60A Contactors

Description	Contact Configuration Code ^①	Catalog Number
Side Mounted		
1NO 1NC	10 01	C320KGS1 C320KGS2
1NO-1NC 2NO 2NC	11 20 02	C320KGS3 C320KGS4 C320KGS5
Top Mounted ^②		
1NO 1NC	10 01	C320KGT1 C320KGT2
1NO-1NC 2NO 2NC	11 20 02	C320KGT3 C320KGT4 C320KGT5
3NO 2NO-1NC 1NO-2NC 3NC 4NO	30 21 12 03 40	C320KGT9 C320KGT10 C320KGT11 C320KGT12 C320KGT13
3NO-1NC 2NO-2NC 1NO-3NC 4NC	31 22 13 04	C320KGT14 C320KGT15 C320KGT16 C320KGT17

^① For Reference Only — not part of Catalog Number. See below left.

^② Cannot be added to contactors or starters mounted in Box 1 (Type 1).

Table 16-95. Auxiliary Contacts — 100 – 400A Contactors

Circuit	Contact Configuration Code ^③	100A Contactors	200 & 300A Contactors
		Catalog Number	Catalog Number

Base Auxiliary Contacts — 100 – 400A Contactors

NO	10	C320KGS31	C320KGS41
NO-NC	11	C320KGS32	C320KGS42

Circuit	Contact Configuration Code ^③	Catalog Number
---------	---	----------------

Auxiliary Contacts — 100 – 400A Contactors

NO	10	C320KGS20
NC	01	C320KGS21
NO-NC ^④	11	C320KGS22

^③ For Reference Only — not part of Catalog Number. See below left.

^④ NO-NC occupies two positions — L2 & L3 or R2 & R3. See Page 16-33.

Table 16-96. Auxiliary Contact Ratings (Amperes)

Current	AC Volts			
	120V	240V	480V	600V
NEMA A600				
Make & Interrupting	60.0	30.0	15.0	12.0
Break	6.0	3.0	1.5	1.0
Continuous	10.0	10.0	10.0	10.0
NEMA P300				
Continuous Thermal Rating: 5 Amperes				
DC Volts	Make/Break Amperes			
125	1.10			
250	0.55			

**Auxiliary Contact Location for
CN35/ECL**

Auxiliary Contacts — Mounting Positions

The sketches below illustrate the maximum number of auxiliary contacts that can be assembled to a contactor and their locations in standard enclosures.

Table 16-97. Auxiliary Contact Mounting Positions

Size	Poles	Available Mounting Positions ①②③		
		Open Type	Type 1	Type 3R, 4X, 12
10 Ampere	2 – 4	T1, L1, R1	L1	L1, T1
20 – 60 Ampere	2 – 3	T1, L1	L1	L1, T1
60 Ampere	4	T1, L1	—	L1, T1
60 Ampere	5	T1, L1	—	L1, T1
100 Ampere	2 – 3	R2, R3, L1, L2, L3	R2, R3, L1, L2, L3	R2, R3, L1, L2, L3
200 Ampere	2 – 3	R2, R3, L1, L2, L3	R2, R3, L1, L2, L3	R2, R3, L1, L2, L3
300 Ampere	2 – 3	R2, R3, L1, L2, L3	R2, R3, L1, L2, L3	R2, R3, L1, L2, L3
400 Ampere	2 – 3	R2, R3, L1, L2, L3	R2, R3, L1, L2, L3	R2, R3, L1, L2, L3

- ① Available positions on contactors or starters other than what is factory installed.
- ② When a pneumatic timer is mounted on contactor, only side mounted auxiliary contact positions are available. The solid-state timer, when added, takes up side mounted auxiliary contact position.
- ③ For 100 – 400A contactors, a base auxiliary contact must be added in position L1 before additional contacts can be mounted.

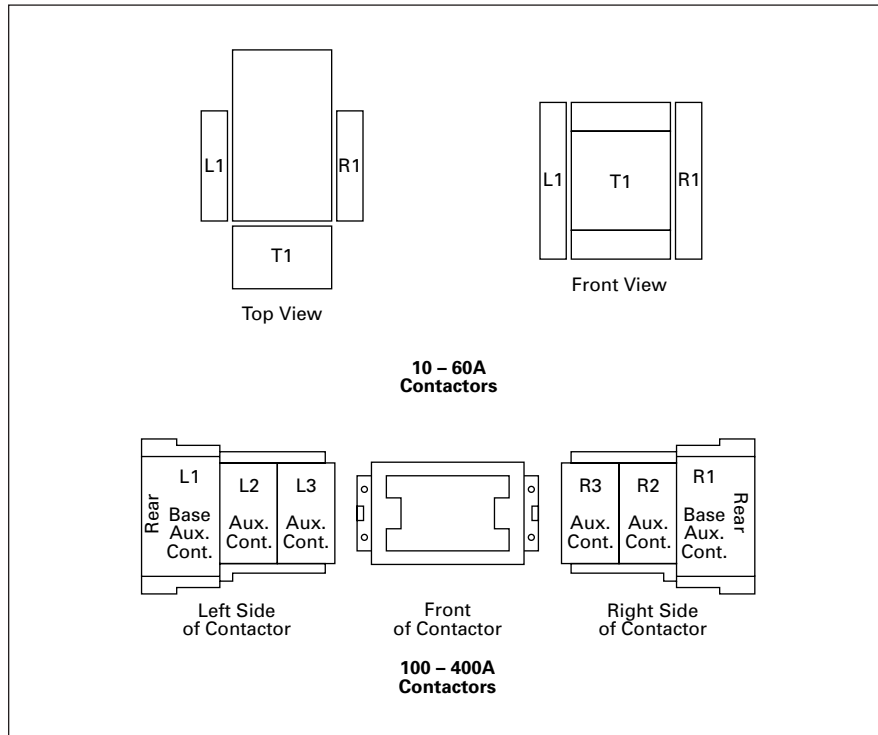

Figure 16-15. Auxiliary Contact Location

**Pneumatic Timers —
Top Mounted for CN35/ECL**



Pneumatic Timer

Attachment mounts on top of 10 – 60A lighting contactors (top mounted auxiliary contacts can not be installed on device when timer is used). Timer unit has DPST timed contacts — circuits in each pole must be the same polarity. Units are convertible from OFF to ON Delay or vice-versa.

Table 16-98. Pneumatic Timers

Timing Range	Catalog Number
.1 to 30 Seconds	C320TP1
10 to 180 Seconds	C320TP2

Table 16-99. Maximum Ampere Ratings

Description	Volts AC			
	120	240	480	600
Make	30.0	15.0	7.5	6.0
Break	3.0	1.5	0.75	0.6

Solid-State Timers for CN35/ECL

Solid-State ON DELAY Timer — Side Mounted on CN35 Freedom Series Lighting Contactors through 60A



This timer is designed to be **wired in SERIES with the load** (typically a coil). When the START button is pushed (power applied to

timer), the ON DELAY timing function starts. At the completion of the set timing period, timer and series wired load will both be energized.

Table 16-100. Product Selection — Mounted Timer

Timing Range	Catalog Number ④⑤⑥
.1 – 1.0 Seconds	C320TDN1_
1 – 30 Seconds	C320TDN30_
30 – 300 Seconds	C320TDN300_
5 – 30 Minutes	C320TDN3000_

- ④ Add operating voltage Suffix to Catalog Number. **A** = 120V, **B** = 240V, **E** = 208V
- ⑤ Rated .5 ampere pilot duty — not to be used on larger contactors.
- ⑥ Terminal connections are quick connects only. Two per side.

Lighting Contactors



Type J Auxiliary Contact

Type J Auxiliary Contact for A202/ECL

- Capable of being field mounted in a contactor or starter (Classes A200, A900 Sizes 00 – 6, V200, V201 vacuum and definite purpose controllers).
- Provides two separate electrical contact sets which wire vertically and are color coded; black designates NC and silver designates NO. Please note that the vertical wiring is contrary to the horizontal wiring of the L-56 auxiliary contacts.
- Designed to fit within dimensions of starter; no additional panel space is required.
- Provides circuit isolation (no polarity restrictions) and single break bifurcated contacts.

Table 16-101. Auxiliary Contact Ratings

Voltage	Make	Break
NEMA A600		
120 – 600V AC	7200 VA	720 VA
72 – 120V AC	60A	720 VA
28 – 72V AC	60 VA	10A
NEMA R300		
28 – 300V DC	28 VA	28 VA

Table 16-102. Auxiliary Contact Types

Contact Type	Max.	Catalog Number
1NO and 1NC	4	J11
2NC	4	J02
2NO	4	J20
1 Coil Clearing NC and 1NO	4	J1C



SS-56 Surge Suppressor

SS-56 Surge Suppressor for A202/ECL

- Designed to be used with magnetic motor controllers through Size 4 in 120V, 60 Hz control circuit applications where electronic equipment is used.
- Steady State Coil Volts: 120, 60 Hz, RMS
- Peak Input Volts: 169.6, 60 Hz, Max. Amplitude
- Max. Ambient Temperature: 65°C
- Nominal Limiting Volts: 270 Peak
- Nominal Rate of Volt Rise: .5 per mS

Table 16-103. Surge Suppressor ①

Type Mounting	Kit Catalog Number
Starter	SS-56

① Can be used on Sizes 5 and 6 with 120V coil. Mounting bracket required — order separately. Mounting Bracket 177C043G04.

F-56 Fuse Block for A202/ECL

- Facilitates installation of fuses (15A, 600V max.) in control circuits.
- Utilizes Bussman type KTK fuses, or equivalent.
- Mounts in same cavity as Type J auxiliary contact.
- No tools or mounting hardware needed.
- Fuse not included.

Table 16-104. Fuse Block

Mounting	Kit Catalog Number
Starter Panel	F56 F56-P

R-56 Interposing Relay for A202/ECL

The R-56AA interposing relay is a low energy solid-state device with a single NO solid-state contact. It can be used as a 120V AC control relay, and will operate on as little as 40V AC input. Is useful in applications requiring long control wiring runs where excessive voltage drop would prevent the contactor or relay from energizing. Will operate a Size 4 contactor from 10,000 feet using 18 AWG wire.

Table 16-105. Interposing Relay

Type Mounting	Kit Catalog Number
Starter or Panel	R56-AA

Power Pole Kit for A202/ECL

- Adds 1NO or 1NC power pole to Size 00 – 1 A201 Class contactors.
- Factory installed or field mountable in load side auxiliary cavities.
- 600V AC.
- Continuous current rating of 18A for Size 0, 27A for Size 1.

Table 16-106. Power Pole Kit ②

Continuous Current Rating	Kit Size	Kit Catalog Number
Normally Open		
18	0	PNO-0
27	1	PNO-1
Normally Closed		
18	0	PNC-0
27	1	PNC-1

② Do not use with DC operated contactors.

Lighting Contactors

Replacement Auxiliary Contacts for A202/ECL

Table 16-107. Replacement Auxiliary Contacts

Contactor Size	Contact Arrangement	Aux. Elect. Contact	
		Catalog Number	Style Number
5, 6	1NO + 1NC	J11	9084A17G01
	2NO	J20	9084A17G02
	2NC	J02	9084A17G03
7, 8	1NO	—	578D461G01
	1NC	—	578D461G03
9	1NO + 1NC	—	843D943G04
	2NO	—	843D943G05
	2NC	—	843D943G06

Extra Auxiliary Contact Kits for A202/ECL

All starters include an auxiliary contact with 1NO and 1NC contact. These kits include an auxiliary contact with contacts as shown, plus operating arm and mounting bracket when required.

Table 16-108. Extra Auxiliary Contact Kits

Contactor Size	Contact Arrangement	Style Number
5, 6	1NO + 1NC	3463D94G18
	2NO	3463D94G04
	2NC	3463D94G19
7, 8 ^①	2NO	818D498G06
	1NO	818D498G04

^① Size 7 and larger use DC coils as standard.

DC Coil Conversion Kits for A202/ECL

Kits listed below include all necessary parts to convert from AC to DC control including the DC coil with built-in diode, rectifier, auxiliary interlock and all mounting hardware.

Table 16-109. DC Coil Conversion Kits

Size	Voltage	Kit Style Number
5	110-120	7864A28G01
	220-240	7864A28G02
	440-480	7864A28G03
6	110-120	7864A29G01
	220-240	7864A29G02
	440-480	7864A29G03

IT. Solid-State Soft Starters

IT. Solid-State Soft Starters

Auxiliary Contacts for S752

The S752 allows for the use of top mounted auxiliary contacts. These contacts can be used for up-to-speed indication.

Table 16-110. S752 Auxiliary Contacts

Poles	Catalog Number
1NO 1NC 1NO/1NC	EMA13 EMA14 EMA15
2NO 2NC 1NO/1NC Logic Level	EMA16 EMA17 EMA70

Table 16-111. S752 — Maximum Number of Auxiliary Contacts

EMA13 1NO	EMA14 1NC	EMA15 1NO/1NC	EMA16 2NO	EMA17 2NC	EMA70 1NO/1NC Logic Level
3	3	2 ^①	2 ^①	2 ^①	3

^① One EMA70 or one EMA13/EMA14 may be used in the center position in conjunction with two of these devices in the outer positions.

Table 16-112. S752 — Auxiliary Contact Ratings (EMA13 – EMA17)

DC-13		AC-15	
U _e Voltage	I _e Amps	U _e Voltage	I _e Amps
24	5	48	8
48	2.5	120	6
125	1.1	240	4
250	0.55	440	2

Table 16-113. S752 — Auxiliary Contact Ratings (EMA70)

DC-12		AC-12	
U _e Voltage	I _e Amps	U _e Voltage	I _e Amps
30	0.1	250	0.1

Starter Network Adapter Product (SNAP)

The Starter Network Adapter Product (SNAP) is a front-mount device that serves as a single DeviceNet node, providing communication capability, control and monitoring to Eaton's Cutler-Hammer Intelligent Technologies (IT) Electromechanical Starters (B – F Frames) as well as the IT S752 SoftStart.

Cat. No. D77B-DSNAP-X1
with 54 mm IT. Starter

When HAND-OFF-AUTO is required, the HOA option will allow for the connection of hard wired operators. This option allows for Hand Control even if the DSNAP is not connected.

For more information and pricing, see Publication No. CA08102001E, Tab 50.

Control Terminal Block for S752

Table 16-114. S752 Control Terminal Block

Description	Catalog Number
Locking Terminal Block	EMA76LS

Surge Suppressors for S801/S811

The surge suppressor can mount on either the line or load side of the IT. Soft Starter. It is designed to clip the line voltage (or load side induced voltage).



Surge Suppressor

Surge Suppressor
Mounted on a 200 mm Device

Table 16-115. Surge Suppressors

Description	Catalog Number
600V MOV for IT. Soft Starters	EMS39
690V MOV for IT. Soft Starters	EMS41

Lug Kits for S801/S811

The 200 mm and 290 mm soft starters do not include lugs.

The 200 mm and 290 mm soft starters each have different lug options based on your wiring needs. Each lug kit contains three lugs which can be mounted on either the load or line side.

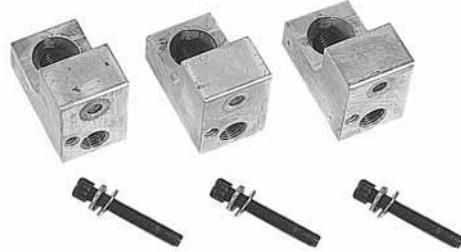

Lug Kits — EML23

Table 16-116. Lug Kits

Frame Size	Frame Designation	Description	Catalog Number
200 mm SSRV	T, U	2 cable connections, 4 AWG to 1/0 cable 1 cable connection, 4/0 to 500 MCM cable 2 cable connections, 4/0 to 500 MCM cable 1 cable connection, 2/0 to 300 MCM cable 2 cable connections, 2/0 to 300 MCM cable	EML22 EML23 EML24 EML25 EML26
290 mm SSRV	V	2 cable connections, 4/0 to 500 MCM cable 4 cable connections, 4/0 to 500 MCM cable 6 cable connections, 4/0 to 500 MCM cable 4 cable connections, 2/0 to 300 MCM cable	EML28 EML30 EML32 EML33 ①

① The EML33 does not have a CSA Listing.

Lug Cover Kits for S801/S811

Replacement covers for the T and V frame are available in case of damage to the existing covers.

Table 16-117. Lug Cover Kits

Description	Catalog Number
Lug Cover T, U Frame	EML27
Lug Cover V Frame	EML34

Digital Interface Module and Control Interface Module

The Digital Interface Module (DIM) and control interface module are available as replacement parts.

Table 16-118. DIM and CIM

Description	Catalog Number
Blank Cover (Filler)	EMA68
DIM for S811	EMA91
CIM for S801	EMA71
CIM for S801 Pump Control Option	EMA72
Panel Mounting Kit — 3 ft. Cable 5 ft. Cable 8 ft. Cable 10 ft. Cable	EMA69A EMA69B EMA69C EMA69D

Control Wire Connector

Table 16-119. Control Wire Connector

Description	Catalog Number
12 pin, 5 mm pitch Connector for Control Wiring	EMA75L

User Manual for S811

A comprehensive user manual is available and can be downloaded free of charge from www.eaton.com by performing a document search for MN03902002E.

Mounting Plates for S801/S811

The Mounting Plates are designed to help make it easy to install or retrofit the soft starter into enclosures and MCCs. The soft starter can be mounted onto the plate prior to installation. The mounting plate is designed with tear drop mounting holes for easier installation.

Table 16-120. Mounting Plates

Description	Catalog Number
Mounting Plate N Frame	EMM13N
Mounting Plate R Frame	EMM13R
Mounting Plate T, U Frame	EMM13T
Mounting Plate V Frame	EMM13V
Fan/Hood Accessory	EMM18

Adapter Plates

The Adapter Plate allows customers to retrofit a V-Frame 290 mm Soft Starter with the U-Frame 200 mm Soft Starter.

Table 16-121. Adapter Plates

Description	Catalog Number
Adapter Plates ②	EMM13U

② For more information see Pub51719.

Vibration Plates for S801/S811

The Vibration Plates allow the soft starter to be applied in high shock and vibration applications. The vibration plate allows vibration up to 5g and shock in up to 40g. The soft starter is mounted onto the vibration plate prior to installation in the panel.

Table 16-122. Vibration Plates

Description	Catalog Number
Vibration Plate N Frame	EMM14N
Vibration Plate R Frame	EMM14R
Vibration Plate T, U Frame	EMM14T
Vibration Plate V Frame	EMM14V

Power Supplies

24V DC Power Supply which can be used with the S752, S801 or S811 SSRV or as a stand-alone device.

Table 16-123. Power Supplies

Description	SSRV	Catalog Number
115V – 240V AC Input	S752	PSS25E
380V – 480V AC Input	S752	PSS25F
115V AC Input	S801/S811	PSS55A
230V AC Input	S801/S811	PSS55B
380 – 480V AC Input	S801/S811	PSS55C

DIN Rail Power Supply Mounting Kit (35 mm)

Table 16-124. DIN Rail Mounting Kit

Description	Catalog Number
DIN Rail Mounting Kit (35 mm)	PSSDIN

Adjustable Frequency Drives

MVX900 Microdrives

Table 16-125. Field Options Kits

Description	Catalog Number
Keypads Copy Keypad Standard Keypad Remote Kit	MVXCOPY MVXKPD MVXRM
Miscellaneous Options Extension I/O DIN Rail	MVXEIO MVXDR
Communications DeviceNet Module	MVXDN
Type 1 Enclosure Small Frame Large Frame	MVXENCS MVXENCL
3% Line Reactor, 1-phase 1/2 hp, 240V 1 hp, 240V 2 hp, 240V 3 hp, 240V	K64-000988-8091 K64-000988-0120 K64-000988-0180 K64-000988-0250
3% Line Reactor, 3-phase 1 hp, 480V 2 hp, 480V 3 hp, 480V 5 hp, 480V 7-1/2 hp, 480V 10 hp, 480V	K64-000989-2091 K64-000989-4091 K64-000989-4091 K64-000989-8091 K64-000989-0180 K64-000989-0250
1/2 hp, 240V 1 hp, 240V 2 hp, 240V 3 hp, 240V 5 hp, 240V 7-1/2 hp, 240V	K64-000988-2091 K64-000988-4091 K64-000988-8091 K64-000988-0120 K64-000988-0180 K64-000988-0250
Output Line Reactor 1 hp, 480V 2 hp, 480V 3 hp, 480V 5 hp, 480V 7-1/2 hp, 480V 10 hp, 480V	K64-000989-2091 K64-000989-4091 K64-000989-4091 K64-000989-8091 K64-000989-0120 K64-000989-0180
EMI Filter 1/2 hp, 240V AC, Single-Phase 1 hp, 240V AC, Single-Phase 2 hp, 240V AC, Single-Phase 3 hp, 240V AC, Single-Phase	K13-000034-0111 K13-000034-0111 K13-000034-0111 K13-000034-0112
1/2 hp, 240V AC, Three-Phase 1 hp, 240V AC, Three-Phase 2 hp, 240V AC, Three-Phase 3 hp, 240V AC, Three-Phase 5 hp, 240V AC, Three-Phase 7-1/2 hp, 240V AC, Three-Phase	K13-000034-0113 K13-000034-0113 K13-000034-0113 K13-000034-0113 K13-000034-0115 K13-000034-0115
1 hp, 480V AC, Three-Phase 2 hp, 480V AC, Three-Phase 3 hp, 480V AC, Three-Phase 5 hp, 480V AC, Three-Phase 7-1/2 hp, 480V AC, Three-Phase 10 hp, 480V AC, Three-Phase	K13-000034-0114 K13-000034-0114 K13-000034-0114 K13-000034-0116 K13-000034-0116 K13-000034-0117
Dynamic Braking Resistor 1/2 – 1 hp, 240V 2 – 3 hp, 240V 5 hp, 240V 7-1/2 hp, 240V	K13-000034-0821 K13-000034-0824 K13-000034-0825 K13-000034-0826
1 hp, 480V 2 – 3 hp, 480V 5 hp, 480V 7-1/2 hp, 480V 10 hp, 480V	K13-000034-0841 K13-000034-0843 K13-000034-0844 K13-000034-0845 K13-000034-0846

NEMA Vacuum Break Control

Lug Sizes

- Size 4 — 12 – 4/0
- NEMA Size 5 & 6 and 320A, 540A & 610A — Supplied without Line or Load Lugs.

Table 16-126. Lug Kits — Consist of 6 Lugs

Size	Description	Catalog Number
5 and 320A	1/0 – 500 kcmil	C325KAL8
6, 540A and 610A	1/0 – 500 kcmil Dbl. Barrel	C325KAL9
610A	1/0 – 600 kcmil Dbl. Barrel	80-19825-2

Field Modification Kits

Auxiliary Electrical Contacts

Size 4 — Three Type J auxiliary contacts may be mounted on the top of Size 4 contactors to provide six auxiliary, isolated 600V, 10A contacts for use in control circuits.

Sizes 5 – 6 — Two Type J auxiliary contacts may be mounted on each side of Size 5 and 6 contactors to provide four auxiliary, isolated 600V, 10A contacts for use in control circuits.

Table 16-127. Auxiliary Electrical Contacts

Contact Arrangement	Catalog Number
1NO, 1NC	J11
2NO	J20
2NC	J02

Table 16-128. Horizontal Mechanical Interlock

Size	Catalog Number
4	180C113G04
5	180C113G16
6	180C113G17

Heater Coils

Table 16-129. Heater Coil Selection for Type B Overload Relay

Motor Full Load Current in Amperes for Use with 3 Heaters Only	
Open Starter	Heater Catalog Number ^①
Ambient Compensated Overload Relay	

Size 4 and 160A

12.8 – 14.1 14.2 – 15.5 15.6 – 17.1 17.2 – 18.9 19.0 – 20.8	FH68 FH69 FH70 FH71 FH72
20.9 – 22.9 23.0 – 25.2 25.3 – 27.8 27.9 – 30.6 30.7 – 33.5	FH73 FH74 FH75 FH76 FH77
33.6 – 37.5 37.6 – 41.5 41.6 – 46.3 46.4 – 50 51 – 55	FH78 FH79 FH80 FH81 FH82
56 – 61 62 – 66 67 – 73 74 – 78 79 – 84	FH83 FH84 FH85 FH86 FH87
85 – 92 93 – 101 102 – 110 111 – 122 123 – 129 130 – 133 —	FH88 FH89 FH90 FH91 FH92 FH93 FH94

Size 5 and 320A with 300/5 Current Transformers

107 – 117 118 – 129 130 – 141 142 – 155 156 – 170	FH23 FH24 FH25 FH26 FH27
171 – 187 188 – 205 206 – 224 225 – 244 245 – 263	FH28 FH29 FH30 FH31 FH32
264 – 292 293 – 318 319 – 350	FH33 FH34 FH35

Size 6 and 540A with 600/5 Current Transformers

236 – 259 260 – 283 284 – 310 311 – 340 341 – 374	FH24 FH25 FH26 FH27 FH28
375 – 411 412 – 448 449 – 489 490 – 527 528 – 585 586 – 600	FH29 FH30 FH31 FH32 FH33 FH34

^① Three are required per overload relay.

Note: For information on H2001 heaters, see **Page 16-6**.

Modification Codes

Table 16-130. A — Ammeters, Auxiliary Contacts, Accelerating Relays, Autotransformers

Modification	Catalog Number Suffix	Description	
Ammeter ^①	A1	Panel Type Wired to Current Transformer in Line 1, Type 1, 12	
		Panel Type Wired to Current Transformer in Line 1, Type 3R, 4X	
	A2	Panel Type, Selector Switch and 3 Current Transformers Wired to Ammeter via Switch, Type 1, 12	
		Panel Type, Selector Switch and 3 Current Transformers Wired to Ammeter via Switch, Type 3R, 4X	
	A3	Miniature (Single-Phase), Type 1, 12	
	A4	Miniature with Selector Switch, Type 1, 12	
	A5	Switchboard (Single-Phase), Type 1, 12	
		Switchboard (Single-Phase), Type 3R, 4X	
	A6	Switchboard with Selector Switch, Type 1, 12	
		Switchboard with Selector Switch, Type 3R, 4X	
	A7	3-Panel Type (Single-Phase), Type 1, 12	
		3-Panel Type (Single-Phase), Type 3R, 4X	
A10	3 Miniature (Single-Phase), Type 1, 3R, 4X, 12		
A11	3 Switchboard Type (Single-Phase), Type 1, 12		
	3 Switchboard Type (Single-Phase), Type 3R, 4X		
A12	Ammeter Order by Description, Type 1, 3R, 4X, 12		
Auto-transformers	A8	hp Rating selection, see Pages 6-21 – 6-28	
	A9	Order by Description	
Top Mounted Auxiliary Contacts ^{②③} (Unwired)	A13	1NO	
	A14	1NC	
	A15	1NO-1NC	
	A16	2NO	
	A17	2NC	
	NEMA Sizes 00 – 2 only (Unwired)	A18	2NO-1NC
		A19	1NO-2NC
IEC Sizes B – L Only (Unwired) XT Series	A20	3NO	
	A21	3NC	
	A22	3NO-1NC	
	A23	2NO-2NC	
	A24	1NO-3NC	
	A25	4NO	
	A26	4NC	
Side Mounted Auxiliary Contacts ^{③④}	A27	1NO	
	A28	1NC	
	A29	1NO-1NC	
	A30	2NO	
	A31	2NC	
	A32	2NO-1NC	
	A33	1NO-2NC	
	A34	3NO	

Table 16-130. A — Ammeters, Auxiliary Contacts, Accelerating Relays, Autotransformers (Continued)

Modification	Catalog Number Suffix	Description
Side Mounted Auxiliary Contacts, continued ^{③④}	A35	3NC
	A36	3NO-1NC
	A37	2NO-2NC
	A38	1NO-3NC
	A39	4NO
	A40	4NC
Auxiliary Contacts ^③	A42	Contacts Mounted on Operating Mechanism of Disconnect Switch, 1NO-1NC
	A43	Contacts Mounted on Operating Mechanism of Disconnect Switch, 2NO-2NC
	A44	With Auxiliary Contact Omitted
Accelerating Relay	A46	For 2-Speed
	A47	2NO/2NC 24V DC Auxiliary Relay — <i>IT</i> . Only

^① Oversize enclosure will be provided for *IT*. Starters.

^② Top mounted auxiliary contacts cannot be added to contactors in Box 1 (Type 1).

^③ Not available for *IT*. Starters.

^④ Available on *XT* Starters for 40A and greater only.

Table 16-131. B — Breaker Modifications, Backspin Timer, Undervoltage Release, Bell Alarm, Bus Choke

Modification	Catalog Number Suffix	Description
Breaker	B1	1NO-1NC Auxiliary Contact on Breaker
	B2	2NO-2NC Auxiliary Contacts on Breaker
	B3	Shunt Trip on Circuit Breaker — 48 – 127V AC or DC
	B4	Shunt Trip on Circuit Breaker — 9 – 24V AC or DC
	B5	Shunt Trip on Circuit Breaker — 208 – 380V AC
	B6	Shunt Trip on Circuit Breaker — 415 – 600V AC or 220 – 250V DC
	B8	Undervoltage Release for Breaker
	B9	Current Limiter Mounted to Breaker
	B10	Breaker — Order by Description
	B11	Thermal Magnetic Breaker
	Backspin Timer	B12
Undervoltage Release	B13	Undervoltage Release for Circuit Breaker — 208 – 240V AC
	B14	Undervoltage Release for Circuit Breaker — 380 – 480V AC
	B15	Undervoltage Release for Circuit Breaker — 525 – 600V AC
Bell Alarm	B16	Bell Alarm for Circuit Breaker
Bus Choke (MVX)	B20	DC Bus Choke, Open Core and Coil ^⑤

^⑤ A DC bus choke may be used in place of an AC line reactor for line harmonic current reduction and for power source exceeding 500 kVA. The DC bus choke will not provide any protection for line voltage unbalance or transients.

Table 16-132. C — Control Power Transformer, *IT*. Power Supplies, Control Relays, Cover Control (not elsewhere defined), Current Transformers, Compelling Relay, Control Wiring, Control Circuit Breaker, Separate Control, Customer-Supplied Components, Custom for Advantage, Contactors, Counter, E-Stop Relay, DC/AC Interface, Separate Source Disconnect, Bypass Contactors

Modification	Catalog Number Suffix	Description
Control Power Transformers Make sure 8th character specifies primary/secondary voltage.	C1	Standard Size Control Transformer, 120V/60 Hz, 110V/50 Hz Secondary with 2 Primary and 1 Secondary Fuse
	C2	Standard Size Control Transformer, 24V/60 Hz Secondary with 2 Primary and 1 Secondary Fuse
	C42	50 VA Extra Capacity CPT 120V/60 Hz, 110V/50 Hz with 2 Primary and 1 Secondary
	C3	100 VA Extra Capacity CPT, 120V/60 Hz, 110V/50 Hz Secondary with 2 Primary and 1 Secondary Fuse
	C4	100 VA Extra Capacity CPT, 24V/60 Hz Secondary with 2 Primary and 1 Secondary Fuse
	C5	200 VA Extra Capacity CPT, 120V/60 Hz, 110V/50 Hz Secondary with 2 Primary and 1 Secondary Fuse
	C6	200 VA Extra Capacity CPT, 24V/60 Hz Secondary with 2 Primary and 1 Secondary Fuse
	C7	300 VA Extra Capacity CPT, 120V/60 Hz, 110V/50 Hz Secondary with 2 Primary and 1 Secondary Fuse
	C8	400 VA Extra Capacity CPT, 120V/60 Hz, 110V/50 Hz Secondary with 2 Primary and 1 Secondary Fuse
	C9	1 kVA Extra Capacity CPT, 120V/60 Hz, 110V/50 Hz Secondary with 2 Primary and 1 Secondary Fuse
	C10	2 kVA Extra Capacity CPT, 120V/60 Hz, 110V/50 Hz Secondary with 2 Primary and 1 Secondary Fuse
	C11	Control Transformer — Order by Description
	C34	CPT with Power Supply for <i>IT</i> or <i>XT</i>
Power Supplies (<i>IT</i> and <i>XT</i> Only)	C27	Separate Control 120V AC to 24V DC
	C28	Power Supply with Extra Capacity — Order by Description
Control Relays	C12	4-Pole Interposing Relay, 600V (2NO/2NC)
	C13	Run Relay, 24V DC (MVX)
	C14 ①	4-Pole, Unwired, A600 Rtg. — 2NO-2NC
	C15 ①	8-Pole, Unwired, A600 Rtg. — 4NO-4NC
	C16	Control Relay — Order by Description
	C18 ①②	3-Wire Control Module (C30 Lighting)
	C20 ①②	2-Wire Control Relay for Mechanical/Magnetic Lighting Contactors
Cover Control	C17 ①	Convert Position 7 to E30 Type Cover Control
	C19 ①	Lock-Off Attachment Added on Cover Control
	C29	Change to E22 (22 mm) Cover Controls

① Not available for *IT* Starters.

② Not available for *XT* Starters.

Table 16-132. C — Control Power Transformer, *IT*. Power Supplies, Control Relays, Cover Control (not elsewhere defined), Current Transformers, Compelling Relay, Control Wiring, Control Circuit Breaker, Separate Control, Customer-Supplied Components, Custom for Advantage, Contactors, Counter, E-Stop Relay, DC/AC Interface, Separate Source Disconnect, Bypass Contactors (Continued)

Modification	Catalog Number Suffix	Description
Current Transformer(s)	C21	In Phase 1
	C22	In Phases 1 and 2
	C23	In 3 Phases
Compelling Relay	C25 ③	—
Control Wiring	C26	Omit Control Wiring
	C30 ③	With Separate Control Wiring and Two 250V Fuses in Holder
	C31 ③	With Common Control Wiring and Two 600V (Class C) Fuses in Holder
	C33	Control Wiring Type — Order by Description
Control Circuit Breaker	C32 ③	Order by Description
Separate Control	C35	Wired for Separate Control (Reduced Voltage)
Customer Supplied Components	C36	Customer Supplied Components to Be Installed
	C37	Customer Supplied Wiring Diagram to Use
Custom for Advantage	C39	Advantage+ Starter Supplied
Contactors/ Starter	C40 ③	Contactors/Starter — Order by Description
Counter	C41 ③	Operations Counter
E-Stop Relay	C43 ③	E-Stop Relay (DeviceNet)
DC/AC Interface	C44 ③⑤	DC/AC Interface Module
Separate Source Disconnect	C45 ③	IEC Separate Source Disconnect for Control Circuitry
Bypass Contactors for <i>IT</i> /MVX Starters (MVX: 1/2 to 5 hp Only)	C46/J1	Isolation Contactor
	C46/J2	Output Contactor
	C46/J3	Bypass Contactor
	C46/J4	Isolation/Output/Bypass Contactor
	C46/J5	3-Contactor Bypass Pkg. for MVX ④

③ Not available for *IT* Starters.

④ Includes CPT, Pilot Lights, Selector Switch, Auxiliary Contacts and Control Relay.

⑤ Not available for *XT* Starters.

Table 16-133. D — Device Labels, Deceleration Relay, Drain and Breather, Duplex Modifications

Modification	Catalog Number Suffix	Description
Device Labels	D1	(Each Label)
Decel. Relay ①	D2	2-Speed
Drain and Breather (Type 7/9 Enclosure) ①	D5	Drain and Breather
	D6	Drain Only
	D7	Breather Only
Duplex Modifications	D12	Alternator Omitted (Deduct Price)
	D14	START/STOP Pushbuttons — Supplied for Each Motor
	D15	HAND/OFF/AUTO Selector Switch — Supplied for Each Motor
	D16	No. 1 Lead - No. 2 Lead Selector Switch for Manual Selection of Lead Pump (Alternator is Omitted)
	D17	Red RUN Pilot Light — Supplied for Each Motor
	D18	Push-to-Test Red RUN Pilot Light — Supplied for Each Motor
	D19	TEST Pushbutton for Each Motor
	D20	CPT, 120V Secondary, 2 Pri. Fuses & 1 Sec. Fuse — Supplied for Ea. Motor
	D21	CPT w/100VA Extra Capacity, 120V Sec., 2 Pri. Fuses & 1 Sec. Fuse — Supplied for Each Motor
	D22	CPT w/200VA Extra Capacity, 120V Sec., 2 Pri. Fuses & 1 Sec. Fuse — Supplied for Each Motor
	D23	CPT for Duplex — Order by Description
	D24	Add 2 Relays to Modify Controller to Operate w/Single-Pole Pilot Devices
	D25	Add 3 Relays to Modify Controller to Operate w/Single-Pole Pilot Devices
	D26	Green — OFF for each starter
D27	Green — Push-to-Test OFF for ea. starter	

① Not available for *IT* or *XT* Starters.**Table 16-134. E — Enclosure Modifications, Elapsed Time Meter, Duplex Outlet, Enclosure for Starter, Enclosure Clear Cover, Enclosure Material**

Modification	Catalog Number Suffix	Description
Enclosure Modifications	E3	Oversize Enclosure
	E4	Enclosure — Order by Description
	E8	Service Entrance Rating w/Ground Bar
	E11	Safety Door Interlock
Elapsed Time Meter	E9	Wired Across Coil, Type 1, 12 Wired Across Coil, Type 3R, 4X
	E10	Elapsed Time Meter — Order by Description
Duplex Outlet	E12	Convenience Duplex Outlet Mounted in Side of Enclosure
Enclosure for Starter ②	E13	Horizontal Combination Starter, Size 0 – 2
	E14	Narrow Combination Starter, Size 0 – 2
Enclosure Clear Cover for <i>XT</i>	E19	Clear Cover for Halyester Enclosure Nonmetallic
Enclosure Material	E20	Convert to 316 Stainless Steel
	E21	Convert from Type 3R to Stainless Steel

② Not available for *IT* or *XT* Starters.**Table 16-135. F — Fuse Clips, Fuse Blocks, Fungus Protection, Fingerproof Covers, EMI Filter**

Modification	Catalog Number Suffix	Description
Fuse Clips ④	F1	Change Fuse Clips in Position 8 to Class J
	F2	Change Fuse Clips in Position 8 to Class H & K (30 & 60 Ampere Only)
Fuse Blocks	F4	Power Fuses Included — Order by Description
	F5	30 Ampere Control Circuit Fuseholder (KTK) Mounted on Panel (Unwired), Fuse Not Supplied
	F6	30 Ampere Control Circuit Fuseholder Mounted on Panel (Unwired), FNQR Fuse Supplied
	F7	3-Pole Power Fuseholder Mounted on Front Contactor
	F8	Separate Fusing of Control Power Supply — <i>IT</i> .
	F10	Blown Fuse Indicator (Not for PFC)
	F21	Class CC Fuses
	EMI Filter (MVX)	F22
F23		1-Phase ③

③ The EMI filter is not necessary to meet the CE mark requirements for EMC when installing the MVX in an EC country.

④ Not available for *XT* Starters.

Table 16-136. G — Ground Fault Relay, Grounding

Modification	Catalog Number Suffix	Description
Ground Fault Relay	G1	Ground Fault Relay (Wired)
	G3	Ground Fault Relay (Unwired)
Grounding	G5	Special Grounding — Order by Description
	G6	Ground Fault Protection Omitted (Advantage)
	G7	Ground Fault Protection and Monitoring Panel

Table 16-137. H — Heater (Space), Heater Packs Installed

Modification	Catalog Number Suffix	Description	
Space Heater	H1	Space Heater and Thermostat	
	H2	Space Heater and NC Interlock	
Install Heater Packs (Freedom Series)	H5	Class 20	
		Class 10	
		/D1 H2001B-3	/D25 H2101B-3
		/D2 H2002B-3	/D26 H2102B-3
		/D3 H2003B-3	/D27 H2103B-3
		/D4 H2004B-3	/D28 H2104B-3
		/D5 H2005B-3	/D29 H2105B-3
		/D6 H2006B-3	/D30 H2106B-3
		/D7 H2007B-3	/D31 H2107B-3
		/D8 H2008B-3	/D32 H2108B-3
		/D9 H2009B-3	/D33 H2109B-3
		/D10 H2010B-3	/D34 H2110B-3
		/D11 H2011B-3	/D35 H2111B-3
		/D12 H2012B-3	/D36 H2112B-3
		/D13 H2013B-3	/D37 H2113B-3
		/D14 H2014B-3	/D38 H2114B-3
		/D15 H2015B-3	/D39 H2115-3
		/D16 H2016B-3	/D40 H2116-3
		/D17 H2017B-3	/D41 H2117-3
		/D18 H2018-3	
		/D19 H2019-3	
		/D20 H2020-3	
		/D21 H2021-3	
		/D22 H2022-3	
/D23 H2023-3			
/D24 H2024-3			

Table 16-138. K — MVX Keypad ^①

Modification	Catalog Number Suffix	Description
Keypad (MVX)	K1	Door-Mounted AFD Keypad (Type 1 and 12)
	K2	Door-Mounted AFD Keypad (Type 3R)
	K3	AFD Copy Keypad (mounted on drive)
	K4	Door-Mounted AFD Copy Keypad (Type 1 and 12)
	K5	Door-Mounted AFD Copy Keypad (Type 3R)

^① See **Tab 7** for more MVX Modifications.

Table 16-139. L — Labels, Line and Load Reactors, Lighting Contactors

Modification	Catalog Number Suffix	Description
Carton Label	L10	Customer Marking — Specify
Line Reactors (MVX)	L12	3% Input Line Reactor, 3-Phase, Open Core and Coil ^②
	L13	3% Input Line Reactor, 1-Phase, Open Core and Coil ^②
	L14	5% Input Line Reactor, 3-Phase, Open Core and Coil ^②
	L15	5% Input Line Reactor, 1-Phase, Open Core and Coil ^②
	L16	Line Reactor — Order by Description
	Load Reactors (MVX)	L17
L18		Load Reactor — Order by Description
Lighting Contactors	L21	1 NC Pole
	L22	2 NC Pole
	L23	3 NC Pole
	L24	4 NC Pole
	L25	5 NC Pole
	L26	6 NC Pole
	L27	7 NC Pole
	L28	8 NC Pole
	L29A	3-Wire 120V AC
	L29B	3-Wire 240V AC
L29C	3-Wire 24V AC	
L29D	3-Wire 24V DC	
L29E	2-Wire 120V AC	
L29F	2-Wire 240V AC	
L29G	2-Wire 24V AC	

^② If the power source exceeds 500 kVA, 3% line unbalance, or if transient voltages from power factor capacitor switching events are present, an input line reactor must be used. The input line reactor will also reduce line current harmonics.

^③ The output line DV/DT filter is required when the distance from the drive to the motor exceeds 33 feet (10m). The total cable run should not exceed 165 feet (50m).

Table 16-140. N — Nameplates

Modification	Catalog Number Suffix	Description
Nameplates	N1	Enclosure Nameplates

Table 16-141. P — Pilot Lights, Pushbuttons, Phase Relays, Potential Transformers, Power Factor Correction Capacitors, Program Timer, Percentage Timer, Photocell

Modification	Catalog Number Suffix	Description
Push-to-Test Pilot Lights	P1	Push-to-Test Pilot Light (Red RUN) Wired to Coil
	P2	Push-to-Test Pilot Light (Green OFF) Wired in Series with Auxiliary Contact
	P3	Combination of P1 and P2 Above
	P4	Push-to-Test Pilot Light (Amber RUN) Wired to Coil
	P49	Push-to-Test Pilot Light (Green RUN)
	P54 ①	Push-to-Test Pilot Light — Red BYPASS (MVX)
	P56 ①	Push-to-Test Pilot Light — Amber INVERTER ENABLE (MVX)
	P57	Push-to-Test Pilot Light — Green STOP
Pushbuttons	P5	EMERGENCY STOP — Mushroom Head
	P6 ①	Pushbutton Omitted
	P7	START/STOP
	P8	ON/OFF
	P9	START
	P10	ON
	P11	OFF
	P12 ①	FORWARD/REVERSE/STOP
	P13 ①	FAST/SLOW/STOP
	P14 ①	FAST/OFF/SLOW
	P15 ①	HIGH/LOW/STOP
	P16 ①	HIGH/LOW
	P17 ①	SLOW/FAST
	P18 ①	Pushbutton with Legend Plate
	P52	UP/STOP/DOWN
P53	OPEN/STOP/CLOSE	
Pilot Lights	P19	With 1 Amber Pilot Light Marked POWER AVAILABLE Wired to Load Side of 2 Fuses or Circuit Breaker
	P20	Pilot Light (Amber RUN) Wired to Coil
	P21 ①	With 1 Red Pilot Light Marked RUN Wired thru NO Auxiliary Contact
	P22 ①	With 1 Push-to-Test Red Light Marked RUN Wired thru NO Auxiliary Contact
	P23	Pilot Light — Red RUN
	P24	Pilot Light — Red ON
	P25	Pilot Light — Green OFF
	P26	Pilot Light — Order by Description
	P29	Pilot Light — Red STOP

① Not available for *IT* Starters.

Table 16-141. P — Pilot Lights, Pushbuttons, Phase Relays, Potential Transformers, Power Factor Correction Capacitors, Program Timer, Percentage Timer, Photocell (Continued)

Modification	Catalog Number Suffix	Description		
Pilot Lights (Continued)	P58	Pilot Light — Red BYPASS (MVX)		
	P59 ②	Pilot Light — Amber INVERTER ENABLE (MVX)		
	P60 ②	Pilot Light — Red INVERTER RUNNING (MVX)		
	P61	Pilot Light — Green STOP		
	P62 ②	FORWARD/REVERSE Red Pilot Lights		
	P63 ②	UP/DOWN Red Pilot Lights		
	P64 ②	OPEN/CLOSE Red Pilot Lights		
	P65 ②	HIGH/LOW Red Pilot Lights		
	P66 ②	FAST/SLOW Red Pilot Lights		
	P67	Green RUN Light		
P68	LED Bulbs			
P69	Blue OVERLOAD Light			
Illuminated Pushbutton	P27	Illuminated Pushbutton — Order by Description		
Phase Loss Relay	P28	Phase Loss Relay		
	P36	Phase Loss Protection Omitted (Advantage)		
	P37	Extended Phase Loss Trip Time (Advantage)		
Phase Reversal Relay	P30	Phase Reversal Relay		
Phase Unbalance Relay	P32	Phase Unbalance Relay		
Phase Monitoring Relay	P34	Phase Monitoring Relay		
Power Factor Correction Capacitors	P38	/F1 20 kVar /F2 25 kVar /F3 30 kVar /F4 35 kVar /F5 40 kVar /F6 45 kVar /F7 50 kVar /F8 60 kVar	/F9 70 kVar /F10 75 kVar /F11 80 kVar /F12 90 kVar /F13 100 kVar /F14 125 kVar /F15 150 kVar /F16 175 kVar	/F17 200 kVar /F18 225 kVar /F19 250 kVar /F20 300 kVar /F21 350 kVar /F22 400 kVar
		Potential Transformers	P39 ②	Potential Transformer — Wired L1 – L2
			P40 ②	Potential Transformer — Wired L1– L2 and L2 – L3
			P41 ②	Potential Transformer — 3 Phases
		Pump Controller	P42	Pump Controller for <i>IT</i> .
		Program Timers	P43	15-Minute Program Timer
			P44	24-Hour Program Timer
			P45	7-Day Program Timer with Day Omission Feature
Percentage Timers	P47	15-Minute Percentage Timer		
	P48	60-Minute Percentage Timer		
Photocell	P70 ②	Photoelectric Receptacle with Photocell		

② Not available for *IT* Starters.

April 2008

Table 16-142. Q — IQ Products, DN50

Modification	Catalog Number Suffix	Description
IQ Products	Q1	IQ 500
	Q3	IQ 1000
	Q5	IQ 4000
	Q8	With Wponi (Advantage)
	Q9	With WCTLponi (Advantage)
IQ Data Metering Module	Q12 ①	IQ Data Metering Module
	Q14	IQ 220 with Cable
DN50	Q13 ①	DeviceNet Input/Output Module

① Not available for *IT* Starters.

Table 16-143. R — Ramp, Relays, Solid-State Electronic Overload Relays, Resets, Overload Relay Modifications, Reversing, DeviceNet Interface

Modification	Catalog Number Suffix	Description
Ramp	R1	Extended Ramp of <i>IT</i> .
Relay ②	R2	Overvoltage Relay
Fixed Heater Overload Relay ③	R8	C316FNA3C .25 – .40A
	R9	C316FNA3D .40 – .63A
	R10	C316FNA3E .63 – 1.00A
	R11	C316FNA3F 1.00 – 1.40A
	R12	C316FNA3G 1.30 – 1.80A
	R13	C316FNA3H 1.70 – 2.40A
	R14	C316FNA3J 2.20 – 3.10A
	R15	C316FNA3K 2.80 – 4.00A
	R16	C316FNA3L 3.50 – 5.00A
	R17	C316FNA3M 4.50 – 6.50A
	R18	C316FNA3N 6.00 – 8.50A
	R19	C316FNA3P 7.50 – 11.00A
	R20	C316FNA3Q 10.00 – 14.00A
	R21	C316FNA3R 13.00 – 19.00A
	R22	C316FNA3S 18.00 – 24.00A
	R23	C316FNA3T 24.00 – 32.00A
	R24	C316KNA3A 18.00 – 25.00A
	R25	C316KNA3B 22.00 – 32.00A
	R26	C316KNA3C 29.00 – 42.00A
	R27	C316KNA3D 36.00 – 52.00A
	R28	C316KNA3E 45.00 – 63.00A
	R29	C316KNA3F 60.00 – 80.00A
	R30	C316PNA3A 65.00 – 90.00A
	R31	C316PNA3B 80.00 – 100.00A
	R32	C316PNA3C 100.00 – 135.00A
	R33	C316PNA3D 110.00 – 150.00A
	R34	C316PNA3E 130.00 – 175.00A
	R35	C316PNA3F 150.00 – 200.00A
	R36	C316SNA3A 130.00 – 185.00A
	R37	C316SNA3B 165.00 – 235.00A
	R38	C316SNA3C 220.00 – 310.00A
	R39	C316SNA3D 285.00 – 400.00A
	R40	C316UNA3A 355.00 – 500.00A
	R41	C316UNA3B 465.00 – 650.00A
R42	C316UNA3C 610.00 – 850.00A	

② Not available for *IT* Starters.

③ Not available for *XT* Starters.

Table 16-143. R — Ramp, Relays, Solid-State Electronic Overload Relays, Resets, Overload Relay Modifications, Reversing, DeviceNet Interface (Continued)

Modification	Catalog Number Suffix	Description		
Fixed Heater Overload Relay, continued ③	R43	Fixed Heater Overload Relay — Order by Description		
	R55	C316FNA3F w/Current Transformer 60.00 – 84.00 FLA		
	R56	C316FNA3G w/Current Transformer 78.00 – 108.00 FLA		
	R57	C316FNA3H w/Current Transformer 102.00 – 144.00 FLA		
	R58	C316FNA3J w/Current Transformer 132.00 – 186.00 FLA		
	R59	C316FNA3K w/Current Transformer 168.00 – 240.00 FLA		
	R60	C316FNA3L w/Current Transformer 210.00 – 310.00 FLA		
Solid-State Electronic Overload Relay ⑤	IEC Frame	NEMA Size	Full Load Current Adjustment Range (A)	3-Phase Automatic/Manual Reset Class 5/10/20/30
		Catalog Number Suffix \rightarrow ⑥		
	B & C	00	0.1 – 0.5	A
			0.4 – 2.0	B
	1.0 – 5.0		C	
	1.6 – 8.0		D	
	C & D	0 & 1	0.1 – 0.5	A
			0.4 – 2.0	B
	1.0 – 5.0		C	
	1.6 – 8.0		D	
6.4 – 32	E			
D	2	9 – 45	F	
		15 – 75	G	
F & G	3	22 – 110	H	
G		4	30 – 150	J
N/A	5	96 – 300	C	
N/A	6	192 – 600	C	
Resets ④	R5	Change External Reset to Internal Reset — Hole Covered with Plug		
	R6	Internal Reset — No Hole Plug		
	R44	Manual Reset Only on Overload Relay		
	R45	Auto Reset Only on Overload Relay		
	R47	Internal Trip Indicator — No External Reset		
	R48	External Reset with External Trip Indicator		
	R49	External Reset with Bell Alarm		
R71	N3R Reset Boot Added (Type 1/12 Only)			
Reversing ④	R54	Reversing Contactor/Starter		
Overload Relay Mods	R53	Anti Plug-In		
	R61	C395 DNA DeviceNet Module		
	R62	C395 Bell Alarm		
	R63	C395 Load Module		
	R64	C395 Program Key		
DeviceNet Interface	R69	DeviceNet Interface		
	R65	Standard Reset for DeviceNet		
	R66	Lighted Reset for DeviceNet		
	R67	Trip Indicator for DeviceNet		
	R68	DeviceNet Communication Interface (MVX)		

④ Not available for *IT* or *XT* Starters.

⑤ Features:

- Self-Powered
- Phase Loss Protection
- Current Adjustment Knob
- \pm 1% Repeat Accuracy
- 1NO and 1NC Isolated Contacts

⑥ Complete Modification Code includes overload range. Example **R61/C**.

Table 16-144. S — System Voltage, Selector Switches, Suppressor, Incomplete Sequence Protection, Single-Phase Jumper, Surge Capacitor, Speed Potentiometer

Modification	Catalog Number Suffix	Description
System Voltage Selection	S1	System Voltage Selection for Internal Components
		/H1 208V 60 Hz
		/H2 240V 60 Hz
		/H3 277V 60 Hz, 1-Ph
		/H4 480V 60 Hz
		/H5 600V 60 Hz
		/H6 796V 60 Hz
		/H7 220V 50 Hz
		/H8 380V 50 Hz
		/H9 415V 50 Hz
		/H10 550V 50 Hz
		/H11 660V 50 Hz
		/H12 380V 60 Hz
		/H13 1500V 60 Hz
	S2	System Voltage Selection — Specify on Order
Selector Switches ①	S3	HAND/OFF/AUTO
	S4	HAND/AUTO
	S5	HAND/OFF/AUTO Selector Switch with 1 Red RUN Pilot Light
	S6	RUN/OFF/AUTO
	S7	AUTO/OFF/TEST
	S8	AUTO/OFF/TEST Selector Switch with 1 Red RUN Pilot Light
	S9	AUTO/OFF/TEST Selector Switch with 1 Red RUN Pilot Light and 1 Green Pilot Light
	S10	OFF/AUTO
	S11	START/STOP
	S12	OFF/ON
	S13 ②	HIGH/LOW
	S14 ②	FAST/OFF/SLOW
	S15 ②	SLOW/FAST
	S16 ②	FORWARD/REVERSE
	S17 ②	HIGH/OFF/LOW
	S18 ②	HIGH/LOW/OFF/AUTO
	S21	HAND/OFF/AUTO Spring Return from Left
	S38 ②	INVERTER/OFF/BYPASS (MVX)
	S41 ②	OPEN/OFF/CLOSE
	S42 ②	FORWARD/OFF/REVERSE
S43 ②	FAST/OFF/SLOW/AUTO	
S19 ②	Selector Switch Omitted (Pump Panels Only)	
S40	Selector Switch — Order by Description	
Suppressor	S24 ②	Transient Suppressor Mounted on Magnet Coil
Surge Suppression	S20	MOV (IT)
Sequence Timer	S26 ②	Sequence Timer (Pump Panels)
Sequence Protection	S27 ②	Incomplete Sequence Protection
Pump	S28	480V BP9000 Pump
Single Phase ②	S29	Convert Contactor or Starter from Three-Phase to Single-Phase — Install Jumper
	S30	Single-Phase Rev. 120V
	S31	Single-Phase Rev. 240V
Surge Capacitor	S37 ②	Surge Capacitor Wired to Disconnect Line Side
Speed Potentiometer	S39 ②	Speed Potentiometer (MVX)

① When using 3-position selector switch with magnetic lighting contactor, mod **C20** must also be used (ECL04, ECL13, ECL15).

② Not available for **IT** Starters.

Table 16-145. T — Timers, Time Delay Relays, Terminal Blocks, Terminal Points, Ring Lug Connections

Modification	Catalog Number Suffix	Description	
Timers	T1 ③	Pneumatic Timer Installed on Contactor, Unwired, 30 Sec. Max.	
	T2 ③	Pneumatic Timer Installed on Contactor, Unwired, 180 Sec. Max.	
	T3	Pneumatic Timer Mounted in Enclosure, Unwired, 180 Sec. Max.	
	T4	Solid-State ON Delay Timer (1 – 30 sec)	
	T5	Solid-State ON Delay Timer (30 – 300 sec)	
	T25	Timer — Order by Description	
Time Delay Relays	T6	Time Delay Relay, 3 Minutes Maximum, Unwired, ON DELAY	
	T7	Time Delay Relay, 3 Minutes Maximum, Unwired, OFF DELAY	
	T8	Time Delay Low Voltage Release Relay	
Terminal Blocks	T9	With 1 Single Circuit Terminal Block, Unwired	
	T10	With 2 Single Circuit Terminal Block, Unwired	
	T24 ③	Power Terminal Block for DeviceNet Overload	
Terminal Points	T11	With 6 Terminal Points, Unwired	
	T12	With 12 Terminal Points, Unwired	
	T13	With 18 Terminal Points, Unwired	
	T14	Terminal Point per Customer Specification, Unwired (Price Each)	
	T15	Terminal Point per Customer Specification, Wired (Price Each)	
	T21 ③	3 Terminals Mounted Between Contactor and Overload for Power Factor Capacitors — Sizes 0 – 2	
	T22 ③	3 Terminals Mounted Between Contactor and Overload for Power Factor Capacitors — Sizes 3 – 4	
	T23 ③	Quick-Connect Terminals Added to DP Contactor/Starter	
	Ring Lug Connections	T16 ④	Ring Lug Connections on Power Wires
		T17 ③	Ring Lug Connections on Control Wires
IT/EM	T30	Reset Only	
	T31	STOP with Reset	
	T32	START/STOP with Reset	
	T33A	HAND/OFF/AUTO with Reset 120V AC	
	T33D	HAND/OFF/AUTO with Reset 24V DC	
	T34	ON/OFF	
	T40	Reset Only (DeviceNet)	
	T41	STOP with Reset (DeviceNet)	
	T42	START/STOP with Reset (DeviceNet)	
	T43A	HAND/OFF/AUTO with Reset 120V AC (DeviceNet)	
	T43D	HAND/OFF/AUTO with Reset 24V DC (DeviceNet)	
	T44	ON/OFF	
	T50	Reset Only	
	T51	STOP with Reset	
	T52	FORWARD/REVERSE/STOP with Reset	
T53A	FORWARD/REVERSE/STOP with Reset 120V AC		
T53D	FORWARD/REVERSE/STOP with Reset 24V DC		
T54	ON/OFF		

③ Not available for **IT** Starters.

④ Not available for **XT** Starters.

Table 16-145. T — Timers, Time Delay Relays, Terminal Blocks, Terminal Points, Ring Lug Connections (Continued)

Modification	Catalog Number Suffix	Description
<i>IT/EM</i> , continued	T60	Reset Only (DeviceNet)
	T61	STOP with Reset (DeviceNet)
	T62	FORWARD/REVERSE/STOP with Reset (DeviceNet)
	T63A	FORWARD/REVERSE/STOP with Reset 120V AC (DeviceNet)
	T63D	FORWARD/REVERSE/STOP with Reset 24V DC (DeviceNet)
	T64	ON/OFF
	T70	Reset Only
	T71	START/STOP with Reset
	T72	HAND/OFF/AUTO – START with Reset
	T73	FORWARD/REVERSE/STOP with Reset
	T74	HAND/OFF/AUTO – FORWARD/REVERSE with Reset
	T75	ON/OFF with Reset
	T76	FAST/SLOW/STOP with Reset
	T77	HAND/OFF/AUTO – FAST/SLOW with Reset

Table 16-146. U — Undervoltage Relay, Time Delay Undervoltage Relay

Modification	Catalog Number Suffix	Description
Undervoltage Relays	U1	Undervoltage Relay, Non-adjustable
	U2	Undervoltage Relay, Adjustable
Time Delay Undervoltage Relays	U4 ^①	Time Delay Undervoltage Relay, Non-adjustable
	U5	Time Delay Undervoltage Relay, Adjustable
Under- and Overvoltage Relay	U7	Under- and Overvoltage Relay

^① Not available for *IT* Starters.

Table 16-147. V — Voltmeter, Varmeter, Vacuum Starter

Modification	Catalog Number Suffix	Description
Voltmeters	V1	1 Panel Type Voltmeter Wired L1 – L2
	V2	Panel Type Voltmeter and Selector Switch Wired to Read Three Line Voltages
	V3 ^②	Miniature Voltmeter Wired L1 – L2
	V4 ^②	Miniature Voltmeter and Selector Switch Wired to Read Three Line Voltages
	V5	Switchboard Type Voltmeter Wired L1 – L2
	V6 ^②	Switchboard Type Voltmeter and Selector Switch Wired to Read Three Line Voltage
	V7	3 Panel Type Voltmeters Wired in Each Phase
	V8 ^②	3 Miniature Voltmeters Wired in Each Phase
	V9	3 Switchboard Type Voltmeters Wired in Each Phase
	V10	Voltmeter — Order by Description
Varmeter ^③	V11	Varmeter
	V12	Varmeter — Order by Description
Vacuum Starter ^③	V13	Vacuum Starter — 1500V Rating

^② Type 1/12 only.

^③ Not available for *XT* Starters.

Table 16-148. W — Wattmeter, Watt-Hour Meter, Wiremarkers, Wiring Diagram

Modification	Catalog Number Suffix	Description
Wattmeter ^④	W1	Wattmeter
	W3	Watt-Hour Meter
Watt-Hour Meter ^④	W5	Watt-Hour Meter with Demand Attachment
	W7	Wiremarkers
Wiremarkers	W8	Wiremarkers — Order per Customer Diagram or Specifications
	W9	Wiremarkers — Order by Description
WYE-Delta hp	W10 ^⑤	See Pages 6-34 – 6-48
Windows in Enclosure	W11	Enclosure Windows (MVX)
Wiring Diagram	W12	Reduced Copy of Custom Wiring Diagram Laminated on Inside of Door

^④ Type 1/12 only.

^⑤ Not available for *XT* Starters.