

DM74LS151 Data Selector/Multiplexer

General Description

This data selector/multiplexer contains full on-chip decoding to select the desired data source. The 'LS151 selects one-of-eight data sources. The 'LS151 has a strobe input which must be at a low logic level to enable these devices. A high level at the strobe forces the W output high, and the Y output low.

The 'LS151 features complementary W and Y outputs.

- Performs parallel-to-serial conversion
- Permits multiplexing from N lines to one line
- Also for use as Boolean function generator
- Typical average propagation delay time data input to W output 12.5 ns
- Typical power dissipation 30 mW

Features

- Select one-of-eight data lines

Connection Diagram

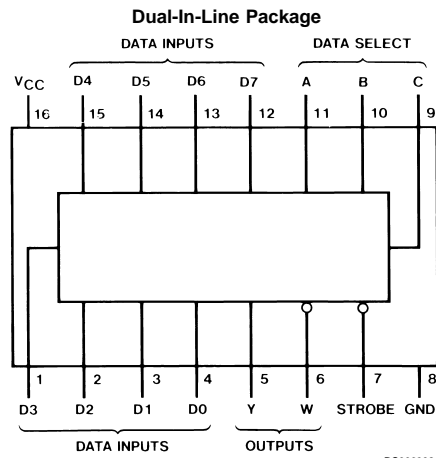

Order Number 54LS151DMQB, 54LS151FMQB, 54LS151LMQB,
DM54LS151J, DM54LS151W, DM74LS151M or DM74LS151N
See Package Number E20A, J16A, M16A, N16E or W16A

Truth Table

Inputs				Outputs	
Select			Strobe S	Y	W
C	B	A			
X	X	X	H	L	H
L	L	L	L	D0	$\overline{D0}$
L	L	H	L	D1	$\overline{D1}$
L	H	L	L	D2	$\overline{D2}$
L	H	H	L	D3	$\overline{D3}$
H	L	L	L	D4	$\overline{D4}$
H	L	H	L	D5	$\overline{D5}$
H	H	L	L	D6	$\overline{D6}$
H	H	H	L	D7	$\overline{D7}$

H = High Level, L = Low Level, X = Don't Care
D0, D1...D7 = the level of the respective D input

Absolute Maximum Ratings (Note 1)

Supply Voltage	7V	DM54LS and 54LS	-55°C to +125°C
Input Voltage	7V	DM74LS	0°C to +70°C
Operating Free Air Temperature Range		Storage Temperature Range	-65°C to +150°C

Recommended Operating Conditions

Symbol	Parameter	DM54LS151			DM74LS151			Units
		Min	Nom	Max	Min	Nom	Max	
V _{CC}	Supply Voltage	4.5	5	5.5	4.75	5	5.25	V
V _{IH}	High Level Input Voltage	2			2			V
V _{IL}	Low Level Input Voltage			0.7			0.8	V
I _{OH}	High Level Output Current			-0.4			-0.4	mA
I _{OL}	Low Level Output Current			4			8	mA
T _A	Free Air Operating Temperature	-55		125	0		70	°C

Note 1: The "Absolute Maximum Ratings" are those values beyond which the safety of the device cannot be guaranteed. The device should not be operated at these limits. The parametric values defined in the "Electrical Characteristics" table are not guaranteed at the absolute maximum ratings. The "Recommended Operating Conditions" table will define the conditions for actual device operation.

Electrical Characteristics

over recommended operating free air temperature range (unless otherwise noted)

Symbol	Parameter	Conditions	Min	Typ (Note 2)	Max	Units
V _I	Input Clamp Voltage	V _{CC} = Min, I _I = -18 mA			-1.5	V
V _{OH}	High Level Output Voltage	V _{CC} = Min, I _{OH} = Max	DM54	2.5	3.4	V
		V _{IL} = Max, V _{IH} = Min	DM74	2.7	3.4	
V _{OL}	Low Level Output Voltage	V _{CC} = Min, I _{OL} = Max	DM54		0.25	0.4
		V _{IL} = Max, V _{IH} = Min	DM74		0.35	0.5
		I _{OL} = 4 mA, V _{CC} = Min	DM74		0.25	0.4
I _I	Input Current @ Max Input Voltage	V _{CC} = Max, V _I = 7V			0.1	mA
I _{IH}	High Level Input Current	V _{CC} = Max, V _I = 2.7V			20	µA
I _{IL}	Low Level Input Current	V _{CC} = Max, V _I = 0.4V			-0.4	mA
I _{OS}	Short Circuit Output Current	V _{CC} = Max	DM54	-20		-100
		(Note 3)	DM74	-20		-100
I _{CC}	Supply Current	V _{CC} = Max (Note 4)		6	10	mA

Note 2: All typicals are at V_{CC} = 5V, T_A = 25°C.

Note 3: Not more than one output should be shorted at a time, and the duration should not exceed one second.

Note 4: I_{CC} is measured with all outputs open, strobe and data select inputs at 4.5V, and all other inputs open.

Switching Characteristics

at V_{CC} = 5V and T_A = 25°C

Symbol	Parameter	From (Input) To (output)	R _L = 2 kΩ				Units
			C _L = 15 pF		C _L = 50 pF		
			Min	Max	Min	Max	
t _{PLH}	Propagation Delay Time Low to High Level Output	Select (4 Levels) to Y		43		46	ns
t _{PHL}	Propagation Delay Time High to Low Level Output	Select (4 Levels) to Y		30		36	ns
t _{PLH}	Propagation Delay Time Low to High Level Output	Select (3 Levels) to W		23		25	ns

Switching Characteristics (Continued)

at $V_{CC} = 5V$ and $T_A = 25^\circ C$

Symbol	Parameter	From (Input) To (output)	$R_L = 2\text{ k}\Omega$				Units
			$C_L = 15\text{ pF}$		$C_L = 50\text{ pF}$		
			Min	Max	Min	Max	
t_{PHL}	Propagation Delay Time High to Low Level Output	Select (3 Levels) to W		32		40	ns
t_{PLH}	Propagation Delay Time Low to High Level Output	Strobe to Y		42		44	ns
t_{PHL}	Propagation Delay Time High to Low Level Output	Strobe to Y		32		40	ns
t_{PLH}	Propagation Delay Time Low to High Level Output	Strobe to W		24		27	ns
t_{PHL}	Propagation Delay Time High to Low Level Output	Strobe to W		30		36	ns
t_{PLH}	Propagation Delay Time Low to High Level Output	D0 thru D7 to Y		32		35	ns
t_{PHL}	Propagation Delay Time High to Low Level Output	D0 thru D7 to Y		26		33	ns
t_{PLH}	Propagation Delay Time Low to High Level Output	D0 thru D7 to W		21		25	ns
t_{PHL}	Propagation Delay Time High to Low Level Output	D0 thru D7 to W		20		27	ns

Logic Diagram

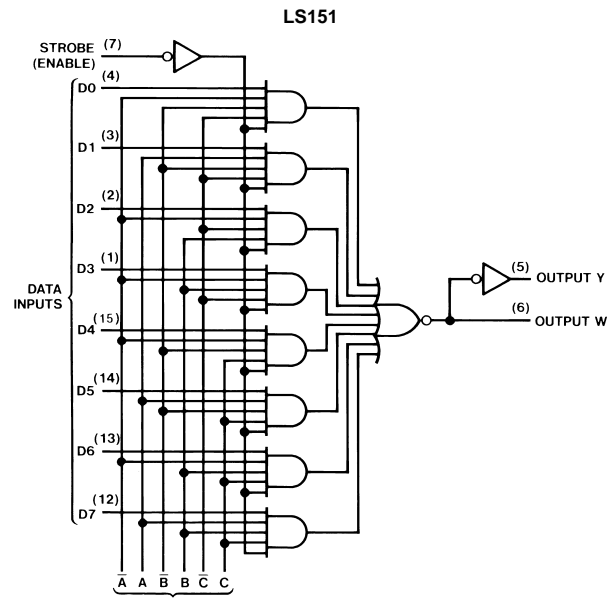

DS006392-2

See Address Buffers to the Right

Address Buffers for 54LS151/74LS151

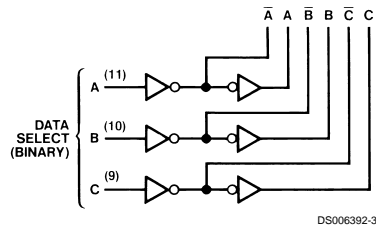

DS006392-3

Physical Dimensions inches (millimeters) unless otherwise noted

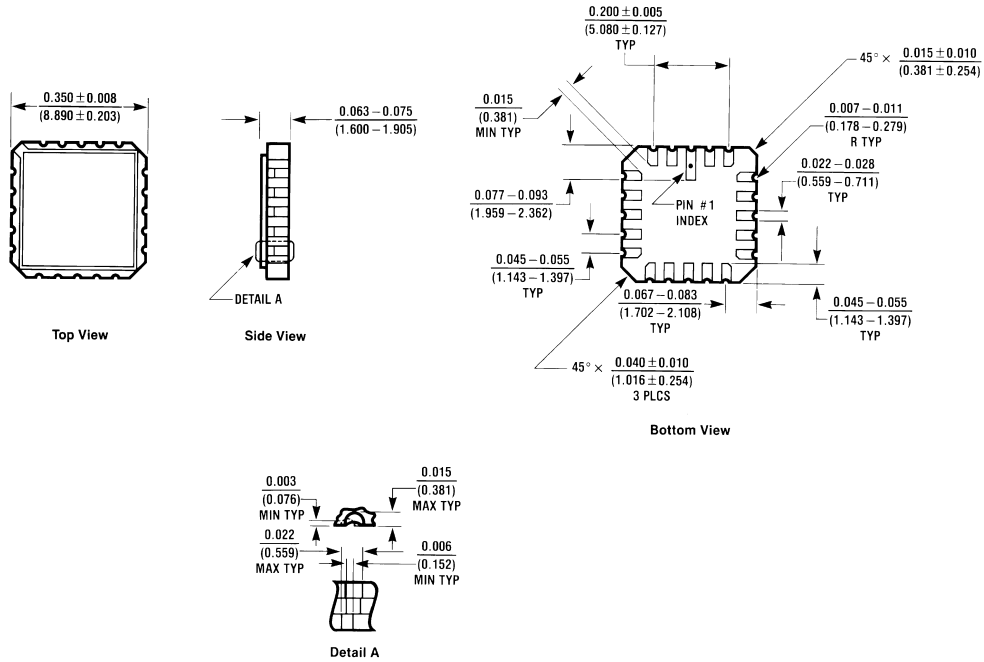

E20A (REV D)

Ceramic Leadless Chip Carrier Package (E)
Order Number 54LS151LMBQ
Package Number E20A

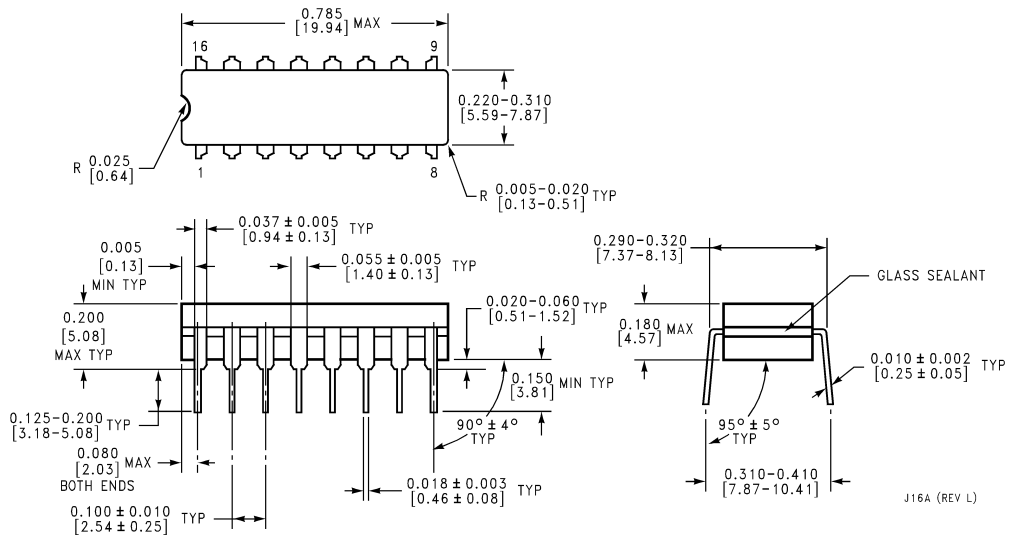

J16A (REV L)

Ceramic Dual-In-Line Package (J)
Order Number 54LS151DMQB or DM54LS151J
Package Number J16A

Physical Dimensions inches (millimeters) unless otherwise noted (Continued)

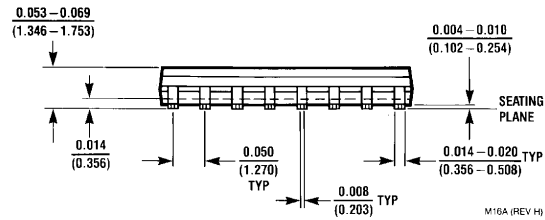
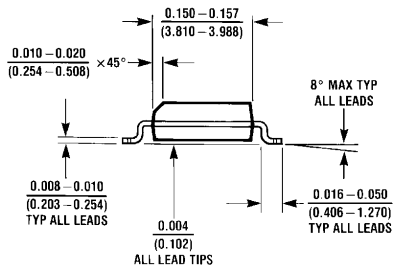
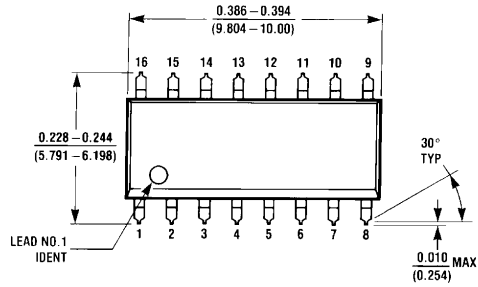

16-Lead Small Outline Molded Package (M)
Order Number DM74LS151M
Package Number M16A

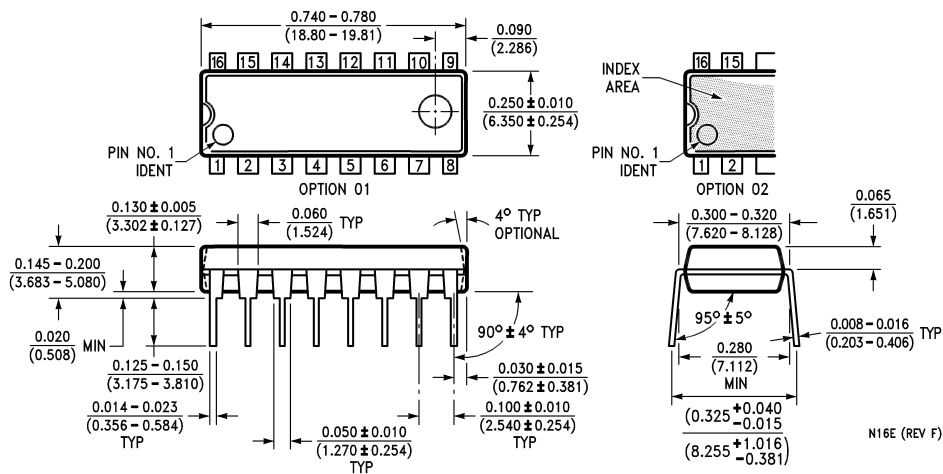

16-Lead Molded Dual-In-Line Package (N)
Order Number DM74LS151N
Package Number N16E

Physical Dimensions inches (millimeters) unless otherwise noted (Continued)

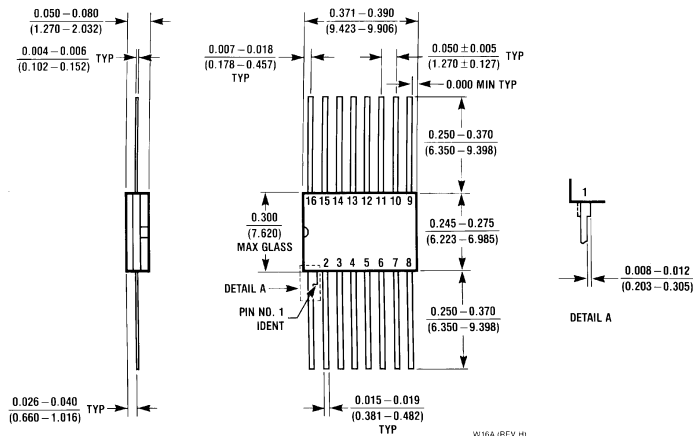

16-Lead Ceramic Flat Package (W)
Order Number 54LS151FMQB or DM54LS151W
Package Number W16A

LIFE SUPPORT POLICY

FAIRCHILD'S PRODUCTS ARE NOT AUTHORIZED FOR USE AS CRITICAL COMPONENTS IN LIFE SUPPORT DEVICES OR SYSTEMS WITHOUT THE EXPRESS WRITTEN APPROVAL OF THE PRESIDENT OF FAIRCHILD SEMICONDUCTOR CORPORATION. As used herein:

1. Life support devices or systems are devices or systems which, (a) are intended for surgical implant into the body, or (b) support or sustain life, and (c) whose failure to perform when properly used in accordance with instructions for use provided in the labeling, can be reasonably expected to result in a significant injury to the user.
2. A critical component in any component of a life support device or system whose failure to perform can be reasonably expected to cause the failure of the life support device or system, or to affect its safety or effectiveness.

Fairchild Semiconductor Corporation Americas
 Customer Response Center
 Tel: 1-888-522-5372

Fairchild Semiconductor Europe
 Fax: +49 (0) 1 80-530 85 86
 Email: europe.support@nsc.com
 Deutsch Tel: +49 (0) 8 141-35-0
 English Tel: +44 (0) 1 793-85-68-56
 Italy Tel: +39 (0) 2 57 5631

Fairchild Semiconductor Hong Kong Ltd.
 13th Floor, Straight Block,
 Ocean Centre, 5 Canton Rd.
 Tsimshatsui, Kowloon
 Hong Kong
 Tel: +852 2737-7200
 Fax: +852 2314-0061

National Semiconductor Japan Ltd.
 Tel: 81-3-5620-6175
 Fax: 81-3-5620-6179

www.fairchildsemi.com