



April 1995

30A, 400V - 600V Ultrafast Diodes

Features

- Ultrafast with Soft Recovery <55ns
- Operating Temperature +175°C
- Reverse Voltage Up To 600V
- Avalanche Energy Rated
- Planar Construction

Applications

- Switching Power Supplies
- Power Switching Circuits
- General Purpose

Description

RURG3040, RURG3050 and RURG3060 are ultrafast diodes with soft recovery characteristics ($t_{RR} < 55ns$). They have low forward voltage drop and are silicon nitride passivated ion-implanted epitaxial planar construction.

These devices are intended for use as freewheeling/clamping diodes and rectifiers in a variety of switching power supplies and other power switching applications. Their low stored charge and ultrafast recovery with soft recovery characteristic minimizes ringing and electrical noise in many power switching circuits reducing power loss in the switching transistors.

PACKAGING AVAILABILITY

PART NUMBER	PACKAGE	BRAND
RURG3040	TO-247	RURG3040
RURG3050	TO-247	RURG3050
RURG3060	TO-247	RURG3060

NOTE: When ordering, use the entire part number

Package

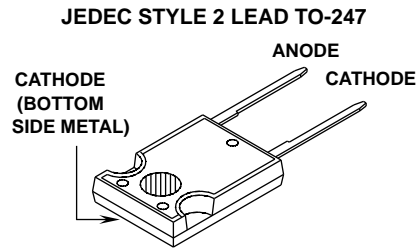

Symbol



Absolute Maximum Ratings $T_C = +25^\circ C$, Unless Otherwise Specified

	RURG3040	RURG3050	RURG3060	UNITS
Peak Repetitive Reverse Voltage V_{RRM}	400	500	600	V
Working Peak Reverse Voltage V_{RWM}	400	500	600	V
DC Blocking Voltage V_R	400	500	600	V
Average Rectified Forward Current $I_{F(AV)}$ ($T_C = +145^\circ C$)	30	30	30	A
Repetitive Peak Surge Current I_{FSM} (Square Wave, 20kHz)	70	70	70	A
Nonrepetitive Peak Surge Current I_{FSM} (Halfwave, 1 Phase, 60Hz)	325	325	325	A
Maximum Power Dissipation P_D	125	125	125	W
Avalanche Energy (L = 40mH) E_{AVL}	20	20	20	mj
Operating and Storage Temperature T_{STG}, T_J	-65 to +175	-65 to +175	-65 to +175	°C

Specifications RURG3040, RURG3050, RURG3060

Electrical Specifications $T_C = +25^\circ\text{C}$, Unless Otherwise Specified

SYMBOL	TEST CONDITION	LIMITS									UNITS
		RURG3040			RURG3050			RURG3060			
		MIN	TYP	MAX	MIN	TYP	MAX	MIN	TYP	MAX	
V_F	$I_F = 30\text{A}, T_C = +25^\circ\text{C}$	-	-	1.5	-	-	1.5	-	-	1.5	V
V_F	$I_F = 30\text{A}, T_C = +150^\circ\text{C}$	-	-	1.3	-	-	1.3	-	-	1.3	V
I_R	$V_R = 400\text{V}, T_C = +25^\circ\text{C}$	-	-	500	-	-	-	-	-	-	μA
	$V_R = 500\text{V}, T_C = +25^\circ\text{C}$	-	-	-	-	-	500	-	-	-	μA
	$V_R = 600\text{V}, T_C = +25^\circ\text{C}$	-	-	-	-	-	-	-	-	500	μA
I_R	$V_R = 400\text{V}, T_C = +150^\circ\text{C}$	-	-	1	-	-	-	-	-	-	mA
	$V_R = 500\text{V}, T_C = +150^\circ\text{C}$	-	-	-	-	-	1	-	-	-	mA
	$V_R = 600\text{V}, T_C = +150^\circ\text{C}$	-	-	-	-	-	-	-	-	1	mA
t_{RR}	$I_F = 1\text{A}, dI_F/dt = 100\text{A}/\mu\text{s}$	-	-	55	-	-	55	-	-	55	ns
	$I_F = 30\text{A}, dI_F/dt = 100\text{A}/\mu\text{s}$	-	-	60	-	-	60	-	-	60	ns
t_A	$I_F = 30\text{A}, dI_F/dt = 100\text{A}/\mu\text{s}$	-	30	-	-	30	-	-	30	-	ns
t_B	$I_F = 30\text{A}, dI_F/dt = 100\text{A}/\mu\text{s}$	-	20	-	-	20	-	-	20	-	ns
$R_{\theta JC}$		-	-	1.2	-	-	1.2	-	-	1.2	$^\circ\text{C}/\text{W}$

DEFINITIONS

V_F = Instantaneous forward voltage ($p_w = 300\mu\text{s}$, $D = 2\%$).

I_R = Instantaneous reverse current.

t_{RR} = Reverse recovery time (See Figure 2), summation of $t_A + t_B$.

t_A = Time to reach peak reverse current (See Figure 2).

t_B = Time from peak I_{RM} to projected zero crossing of I_{RM} based on a straight line from peak I_{RM} through 25% of I_{RM} (See Figure 2).

$R_{\theta JC}$ = Thermal resistance junction to case.

E_{AVL} = Controlled avalanche energy (See Figures 7 and 8).

p_w = pulse width.

D = duty cycle.

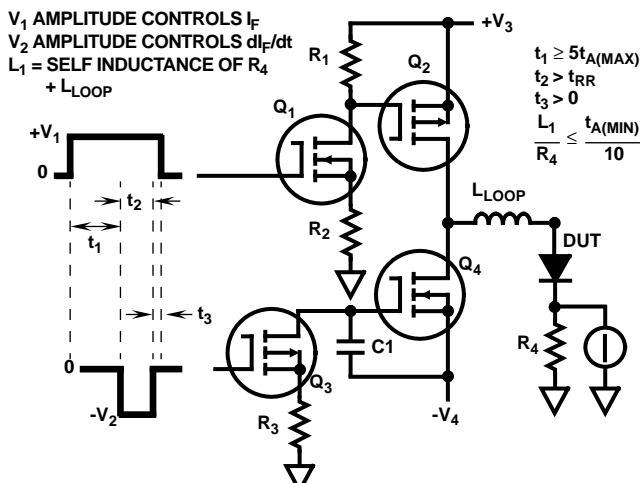

FIGURE 1. t_{RR} TEST CIRCUIT

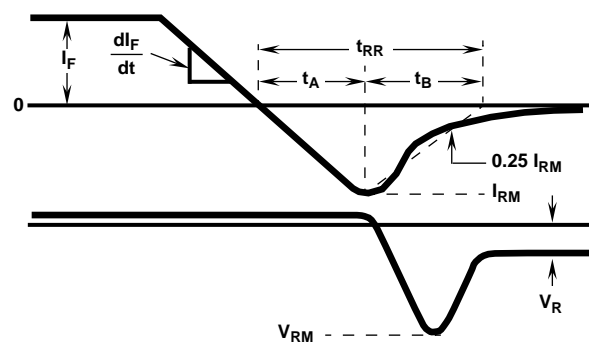

FIGURE 2. t_{RR} WAVEFORMS AND DEFINITIONS

Typical Performance Curves

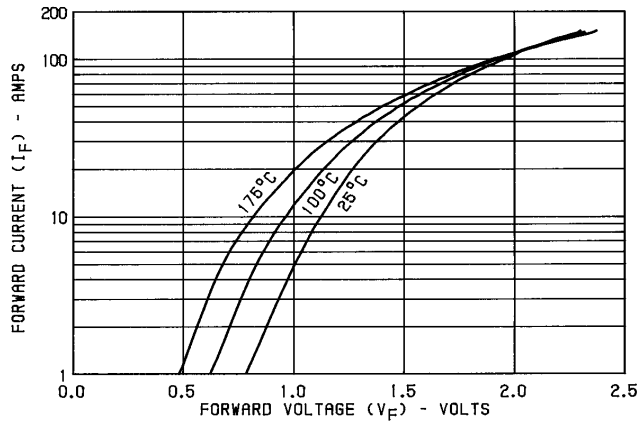

FIGURE 3. TYPICAL FORWARD CURRENT vs FORWARD VOLTAGE DROP

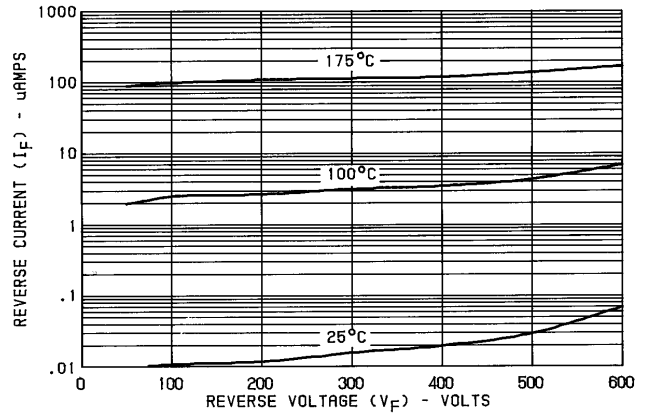

FIGURE 4. TYPICAL REVERSE CURRENT vs VOLTAGE

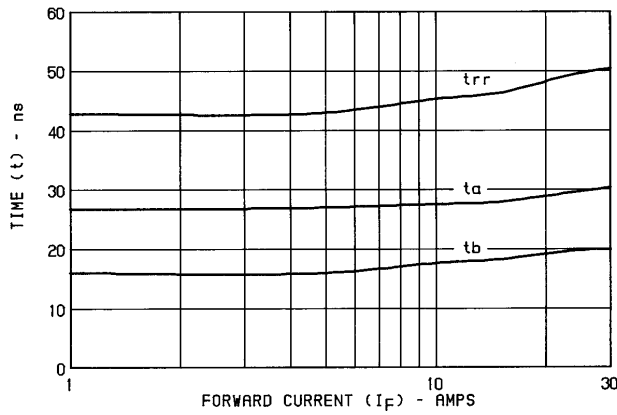

FIGURE 5. TYPICAL t_{RR} , t_A AND t_B CURVES vs FORWARD CURRENT

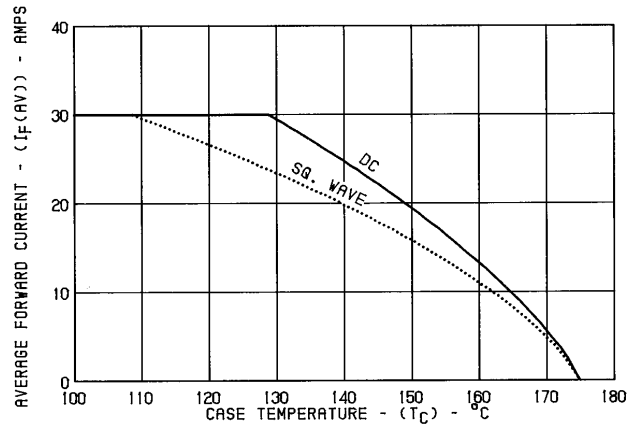

FIGURE 6. CURRENT DERATING CURVE FOR ALL TYPES

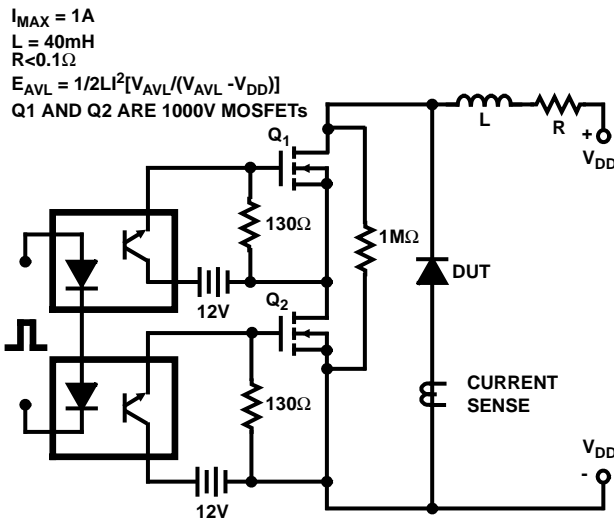

FIGURE 7. AVALANCHE ENERGY TEST CIRCUIT

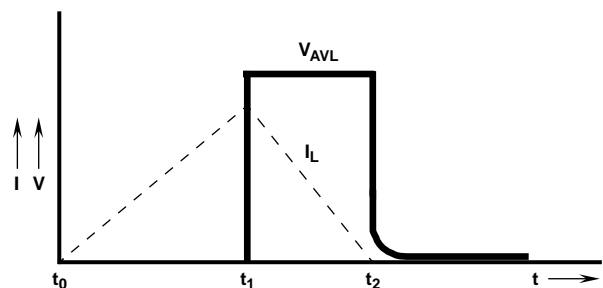

FIGURE 8. AVALANCHE CURRENT AND VOLTAGE WAVEFORMS