

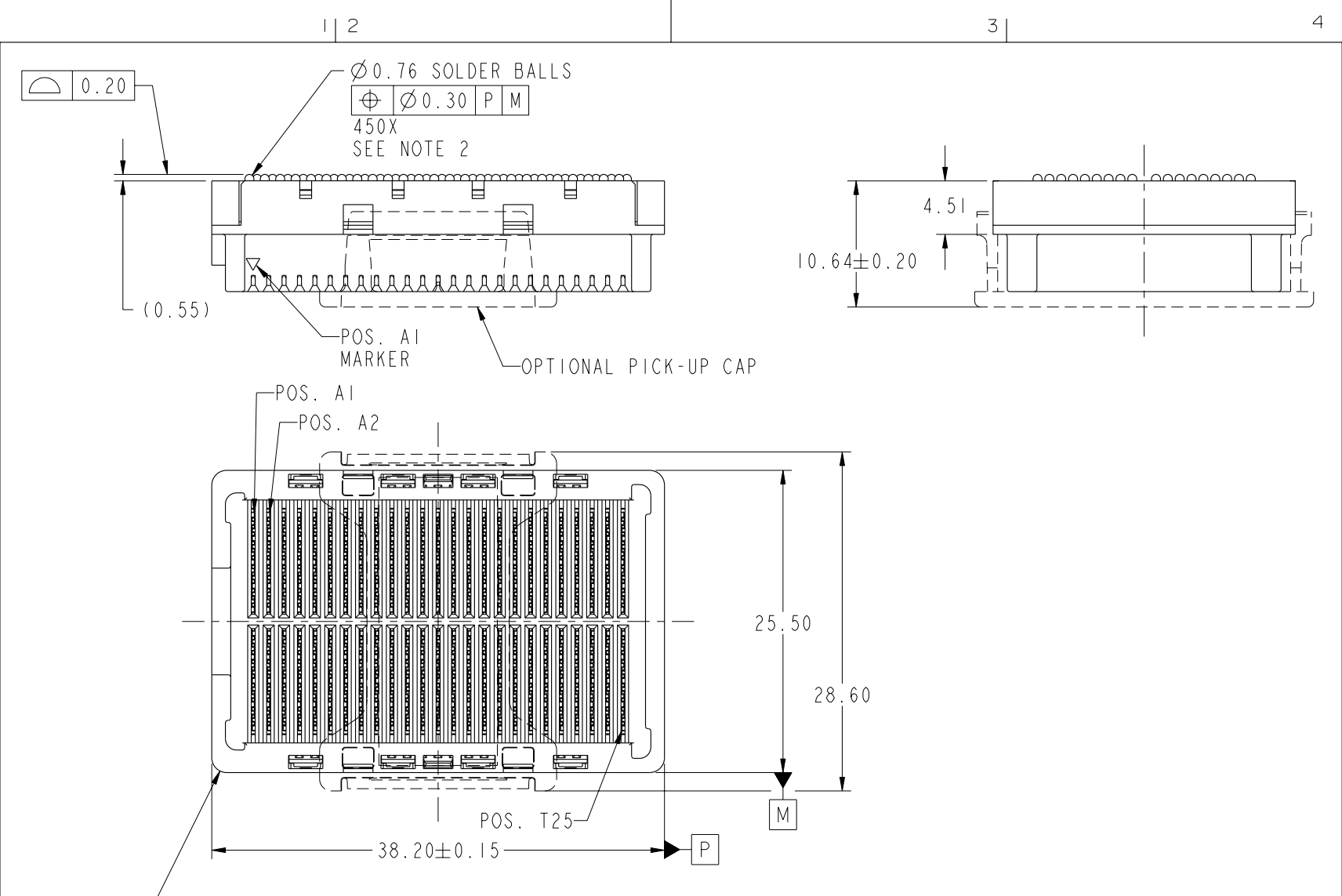

This document is the property of and embodies CONFIDENTIAL and PROPRIETARY information of FCI. No part of the information shown on this document may be used in any way or disclosed to others without the written consent of FCI. Copyright FCI.



mat'l code				SEE NOTE 1		tolerances unless otherwise specified		CUSTOMER		FCI www.fciconnect.com	
ltr	ecm no.	dr	date	linear	$0.X \pm 0.3$		COPY		title		
A	V06-0001	DAI	01/10/06		$0.XX \pm 0.10$		projection		GIG-Array		
C	V06-0435	LP	2006/05/08	angles	$0.XXX \pm 0.050$		MM		5mm RECP. ASSY. 200 SIG. POS.		
D	V06-0523	LP	2006/05/31		$0^\circ \pm 2^\circ$		scale		product family GIG-Array code		
E	V06-0558	LP	2006/06/21	chr	D. JOHNSON	11/14/01	2:1	size		213	
				appd	D. JOHNESCU	11/14/01		A		55740	
						D. JOHNESCU	11/14/01			1 of 4	
sheet	revision	E	E	E	E						
index	sheet	1	2	3	4						



This document is the property of and embodies CONFIDENTIAL and PROPRIETARY information of FCI. No part of the information shown on this document may be used in any way or disclosed to others without the written consent of FCI. Copyright FCI.

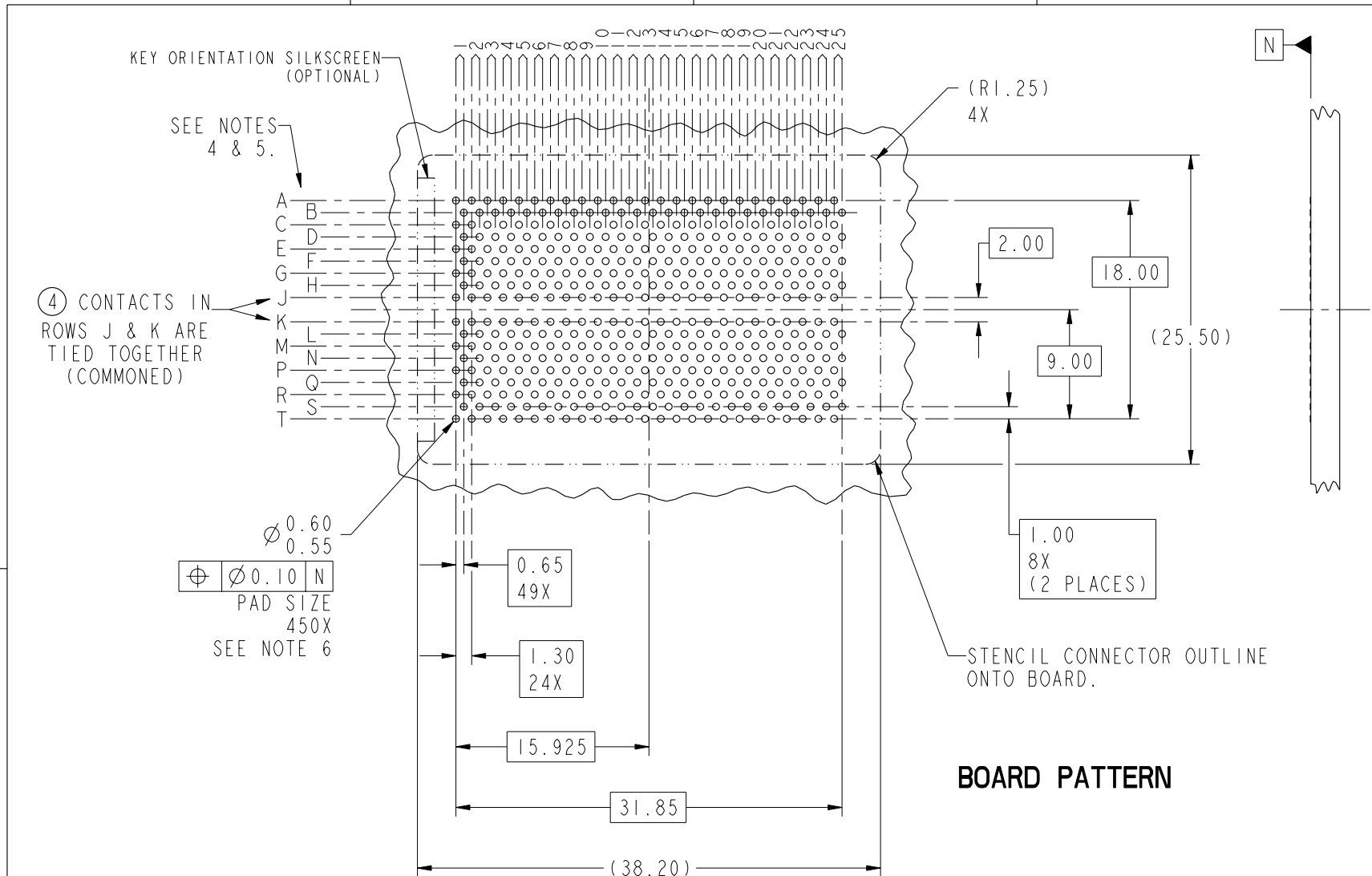

mat'l code				SEE NOTE 1		tolerances unless otherwise specified		CUSTOMER		FCI www.fciconnect.com	
ltr	ecr no.	dr	date	linear	0.X ±0.3		COPY		projection	title	
E					0.XX ±0.10		MM			GIG-Array	
					0.XXX ±0.050		←			5mm RECP. ASSY. 200 SIG. POS.	
				angles	0° ±2°		scale		product family		
				dr	R. JOHNSON	11/14/01	2:1		GIG-Array		
				enr	D. JOHNESCU	11/14/01			code		
				chr	D. JOHNESCU	11/14/01			size		
				appd	D. JOHNESCU	11/14/01			dwg no		
sheet index		revision sheet						A		55740	
										213	
										sheet	
										2	



This document is the property of and embodies
 CONFIDENTIAL and PROPRIETARY information of FCI.
 No part of the information shown on this
 document may be used in any way or disclosed
 to others without the written consent of FCI.
 Copyright FCI.

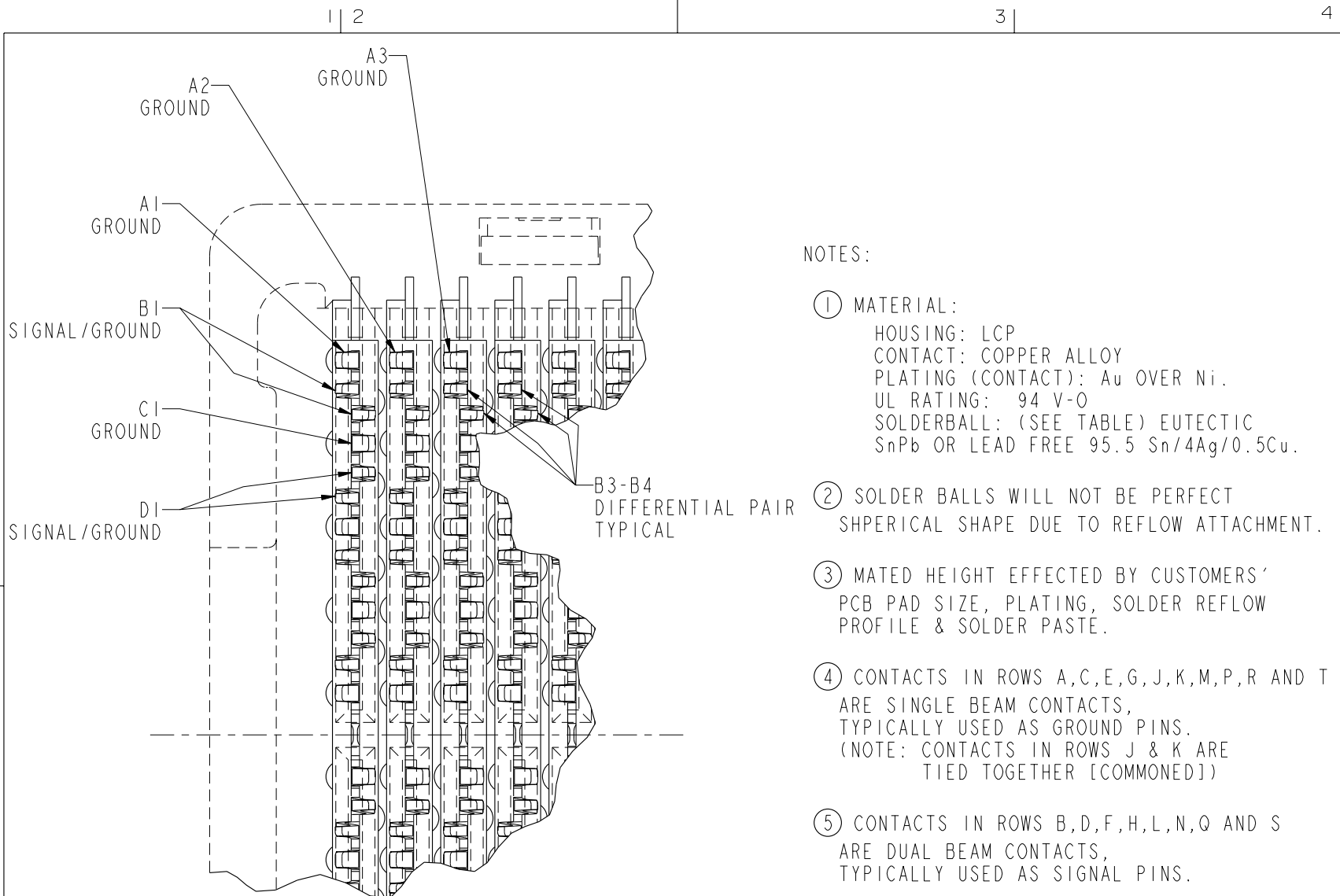

NOTES:

- ① MATERIAL:
 HOUSING: LCP
 CONTACT: COPPER ALLOY
 PLATING (CONTACT): Au OVER Ni.
 UL RATING: 94 V-0
 SOLDERBALL: (SEE TABLE) EUTECTIC
 SnPb OR LEAD FREE 95.5 Sn/4Ag/0.5Cu.
- ② SOLDER BALLS WILL NOT BE PERFECT SPHERICAL SHAPE DUE TO REFLOW ATTACHMENT.
- ③ MATED HEIGHT EFFECTED BY CUSTOMERS' PCB PAD SIZE, PLATING, SOLDER REFLOW PROFILE & SOLDER PASTE.
- ④ CONTACTS IN ROWS A,C,E,G,J,K,M,P,R AND T ARE SINGLE BEAM CONTACTS, TYPICALLY USED AS GROUND PINS. (NOTE: CONTACTS IN ROWS J & K ARE TIED TOGETHER [COMMONED])
- ⑤ CONTACTS IN ROWS B,D,F,H,L,N,Q AND S ARE DUAL BEAM CONTACTS, TYPICALLY USED AS SIGNAL PINS.

RECEPTACLE INTERFACE DESCRIPTION

mat'l code		SEE NOTE 1		tolerances unless otherwise specified		CUSTOMER		FCI		www.fciconnect.com	
ltr	ecr no.	dr	date	linear	0.X ±0.3	projection	COPY		title		
E					0.XX ±0.10				GIG-Array		
				angles	0.XXX ±0.050				5mm RECP. ASSY. 200 SIG. POS.		
				dr	R. JOHNSON 11/14/01	MM	product family		GIG-Array		code
				enr	D. JOHNESCU 11/14/01		size		dwg no		213
				chr	D. JOHNESCU 11/14/01	7:1	A		55740		sheet
				appd	D. JOHNESCU 11/14/01						3
sheet index		revision sheet									

PRODUCT NUMBER	SOLDER BALL
55740-001	SnPb
55740-001LF	SnAgCu LEADFREE SEE NOTE 7 & 8

FLAT AREA FOR OPTIONAL PICK-UP CAP
SCALE 2:1

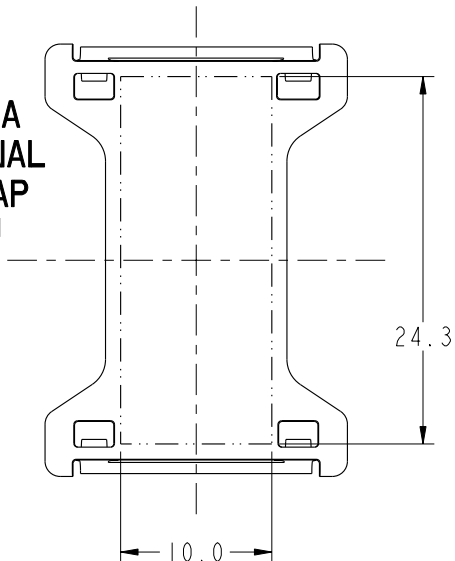

DIM "A" REF. MATED HEIGHT AFTER REFLOW SEE NOTE 3.

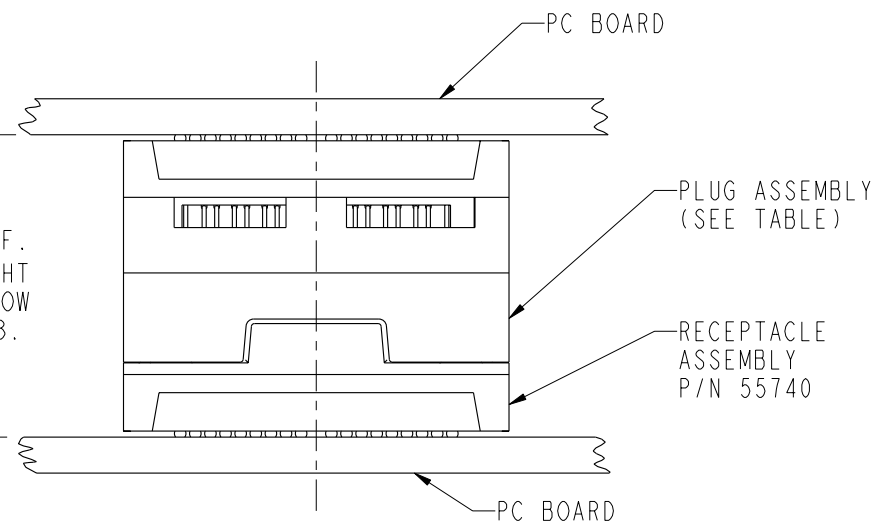

END VIEW OF MATED CONNECTORS
SCALE 2:1

DIM. "A"	PLUG ASSEMBLY P/N
15	55737
17	10026802
18	10030626
20	55738
25	55739

- 6. SPECIFIED POSITIONAL TOLERANCE DEFINES PAD TO PAD LOCATION WITHIN LAND PATTERN. POSITIONAL TOLERANCE OF LAND PATTERN TO FUDICIAL MARKS OR PCB DATUMS SHALL BE DEFINED BY CUSTOMER. FOR RECOMMENDED PRODUCT APPLICATION AND PCB DESIGN DETAILS, SEE DOC. NO. GS-20-016.
- 7. FOR PROPER APPLICATION FOLLOW FCI APPLICATION SPECIFICATION GS-20-033. LEAD FREE SOLDER BALLS WILL NOT SOLDER PROPERLY IN A LEADED SOLDER PROCESS DUE TO A HIGHER REFLOW TEMPERATURE. LEADFREE PRODUCT IS THEREFORE NOT BACKWARDS COMPATIBLE WITH LEADED OR SOME SOLDERING APPLICATIONS. REFERENCE FCI APPLICATION SPECIFICATION.
- 8. THIS PRODUCT MEETS THE EUROPEAN UNION DIRECTIVES AND OTHER COUNTRY REGULATIONS AS DESCRIBED IN GS-22-008. PRODUCT MEETING THIS DIRECTIVE IS IDENTIFIED IN THE CODE NUMBER MARKED ON EACH PART BY HAVING AN "X" IN THE SEVENTH CHARACTER POSITION.

mat'l code				SEE NOTE 1		tolerances unless otherwise specified		CUSTOMER		FCI www.fciconnect.com	
ltr	ecr no.	dr	date	linear	0.X ±0.3		COPY		projection	title	
E					0.XX ±0.10		MM			GIG-Array	
					0.XXX ±0.050		← MM →			5mm RECP. ASSY. 200 SIG. POS.	
				angles	0° ±2°		scale		product family		
				dr	R. JOHNSON	11/14/01	2:1		GIG-Array		
				engr	D. HARPER	11/10/01			code		
				chr	D. JOHNESCU	11/14/01			size		
				appd	D. JOHNESCU	11/14/01			dwg no		
sheet index		revision sheet						A		213	
								55740		sheet 4	



This document is the property of and embodies CONFIDENTIAL and PROPRIETARY information of FCI. No part of the information shown on this document may be used in any way or disclosed to others without the written consent of FCI. Copyright FCI.