

PRODUCT DATASHEET

75VA CHASSIS MOUNTED TRANSFORMER



- DE Designed, Manufactured and tested in accordance with **BS3535**, **EN60742***, **EN61558***, **EN60950**.
- DE Single 230V or Dual 115V Primaries.
- DE 4800V isolation between primary and secondary
- DE CE Marked.
- DE Comprehensive choice of Secondary Voltages.
- DE Flame Retardant materials to UL94-V0.
- DE Fully shrouded double section construction.
- DE Multiple fixing holes

Weight	1.48	Kg
Typical Regulation	8	%
Frequency	50/60	Hz
Max Ambient	25	°C
Bobbin Material	UL94-V0 Class "B" 130°C	

*requires additional over-current /over-temperature protection.

Please see sheet 2 for part numbers.



DAGNALL ELECTRONICS LIMITED

Shuttleworth Road, Elms Industrial Estate, Bedford. MK41 0EP UK
TEL +44(0)1234 330077 FAX +44(0)1234 330088
E-mail sales@dagnall-electronics.com

Iss 1 10/07/03

2 of 4

Part Numbers

Part No	Primary	Secondary	Recommended Secondary Fuse
D3056	230V	6+6V	6.3AT
D3057	230V	9+9V	4AT
D3058	230V	12+12V	3.15AT
D3059	230V	15+15V	2.5AT
D3060	230V	50+50V	0.8AT
D3061	115+115V	6+6V	6.3AT
D3062	115+115V	9+9V	4AT
D3063	115+115V	12+12V	3.15AT
D3064	115+115V	15+15V	2.5AT
D3065	115+115V	50+50V	0.8AT

Please see sheets 3 and 4 for dimensions, pin outs and connection information.

DAGNALL ELECTRONICS LIMITED

Shuttleworth Road, Elms Industrial Estate, Bedford. MK41 0EP UK

TEL +44(0)1234 330077 FAX +44(0)1234 330088

E-mail sales@dagnall-electronics.com

Issue 1. 10/07/03

3 of 4

PRODUCT DATASHEET

75VA CHASSIS MOUNTED TRANSFORMER

Outline Drawing

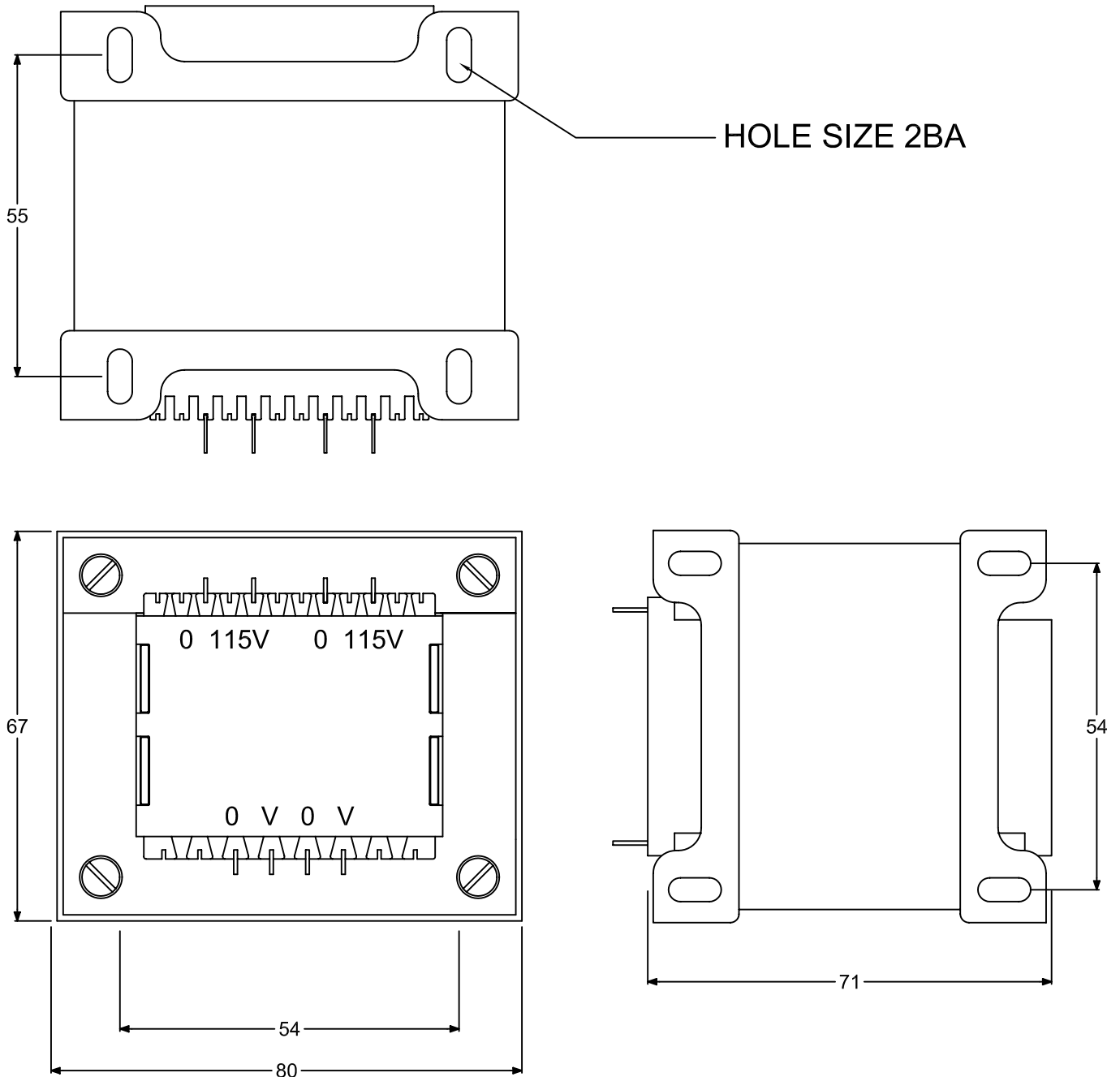

DAGNALL ELECTRONICS LIMITED

Shuttleworth Road, Elms Industrial Estate, Bedford. MK41 0EP UK

TEL +44(0)1234 330077 FAX +44(0)1234 330088

E-mail sales@dagnall-electronics.com

Issue 1. 16/06/03

4 of 4

PRODUCT DATASHEET

75VA CHASSIS MOUNTED TRANSFORMER

Connection Diagrams for D3056

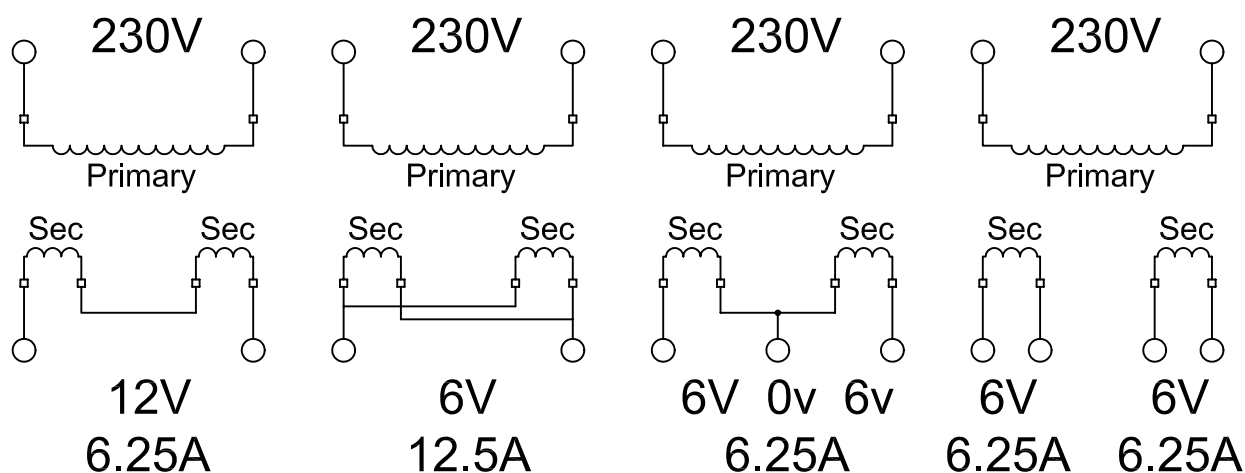

Connection Diagrams for D3061 - 115V supply

