

Form 1106-100618

Part Number	Description
SNAP-LCM4	SNAP Modular M4 Controller

Description

The SNAP-LCM4 is a powerful industrial controller that provides real-time control and communication to input/output (I/O) systems, serial devices, motion controllers, and networks.

Opto 22's fastest controller to date, the SNAP-LCM4 fits today's demanding, high-speed application requirements.

The SNAP-LCM4 modular controller features powerful communications capabilities, built-in diagnostics, a 32-bit processor, and a variety of expansion options. Opto 22 modular controllers are designed to take advantage of the Opto 22 intelligent distributed I/O architecture and provide a solid hardware foundation for the Opto 22 FactoryFloor® software suite.

The SNAP-LCM4 provides power and performance in a package that integrates seamlessly with other Opto 22 SNAP products. Designed specifically for industrial applications, the controller provides Ethernet, ARCNET, and serial communication options for

flexibility. Serial ports provide an interface with Opto 22 I/O and also with radio modems, cellular modems, and even satellite communications equipment, as well as any third-party serial device.

The SNAP-LCM4 handles program control and host communications with a 32-bit Motorola microprocessor. This processor board is combined with a 4-slot Opto 22 expansion bus (M4BUS). Standard on-board communication ports include the following:

- One dedicated Opto 22 remote I/O port (2-wire RS-485 with interrupt capability)
- Three RS-232 or RS-485 (2-wire or 4-wire) serial ports, with baud rates up to 115.2 kBd.

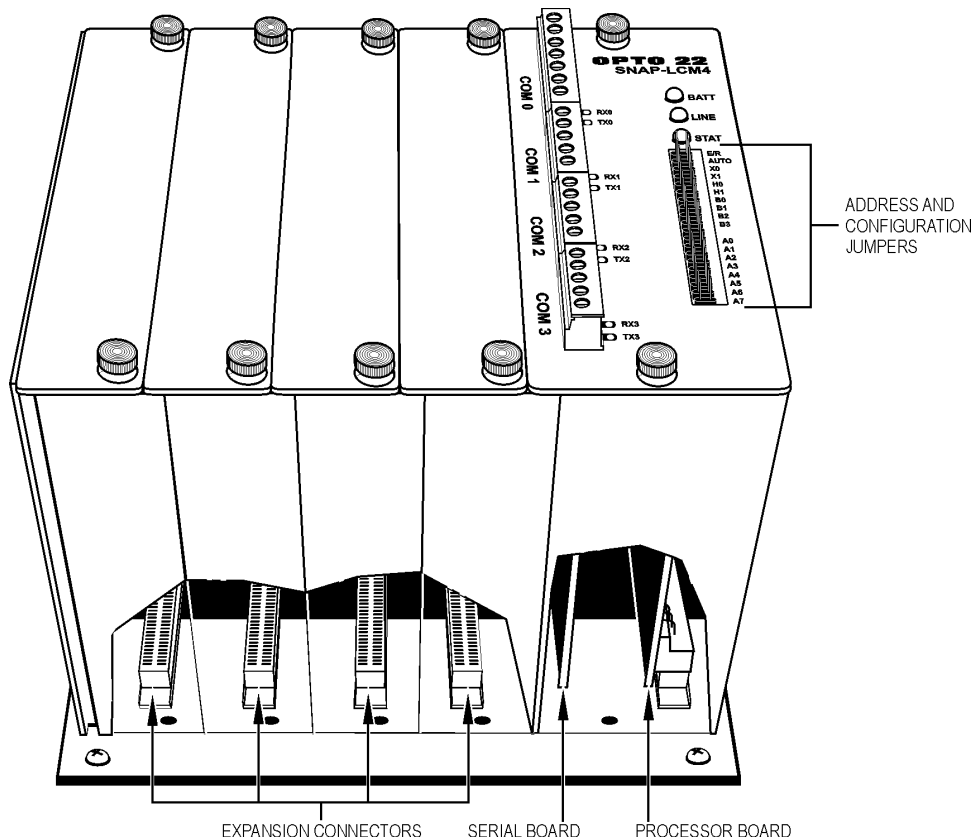

Form 1106-100618

Description (continued)

Software

The SNAP-LCM4 is designed to work with FactoryFloor, Opto 22's powerful suite of Microsoft® Windows® 32-bit software. FactoryFloor consists of four integrated components:

- OptoControl™, a graphical, flowchart-based development environment for machine control and process applications
- OptoDisplay™, an intuitive, shared database, human-machine interface (HMI) and trending package, including alarming
- OptoServer™, a robust, OPC-compliant data server that connects the controller network with the PC network
- OptoConnect™, a bidirectional link between the Opto 22 database in the controller and Microsoft's SQL Server and Access databases.

The SNAP-LCM4 is configured using OptoControl on a PC workstation. OptoControl is an easy to use, self-documenting control environment that uses a plain English command set and a long tagname database that is shared by all FactoryFloor components.

The SNAP-LCM4 controller also works with Opto 22's Classic 16-bit software: Cyrano®, Mistic™ MMI, and Mistic Data Server (MDS).

Interface Options (M4BUS Expansion Cards)

The M4BUS has four expansion slots to accommodate a variety of communication interface cards. The following modular interface cards provide I/O or network connectivity:

Interface Adapter Card	Use	Current Draw
M4SARC	High-performance coaxial ARCNET	200 mA
M4DUALARC	Dual twisted-pair ARCNET (for HA brains)	150 mA
M4SARCF	Fiber Optic ARCNET	250 mA
M4SARCFR	Fiber Optic ARCNET with repeater	350 mA
M4SENET-100	10/100 Mbps Ethernet (Category 5 UTP)	1.00 A

NOTE: Only one Ethernet card per controller is supported at this time. The Ethernet card currently accommodates 128 sessions, including FactoryFloor, Ethernet brains, and other Ethernet devices.

SNAP-LCM4 Top Cover

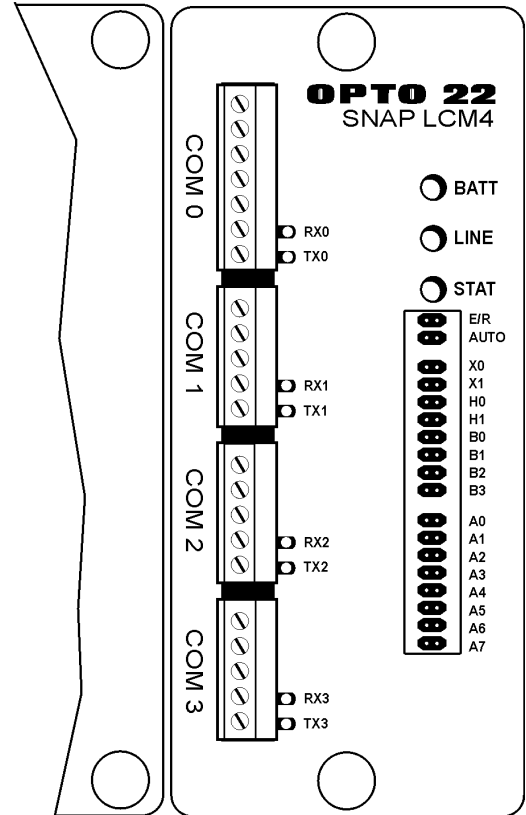

Form 1106-100618

*Description (continued)**I/O Connectivity*

Any of the built-in RS-485/422 ports can be used as a serial link to communicate with Opto 22 remote digital and analog I/O units. Up to 4,096 I/O points can be connected to each port.

Power Requirements

The SNAP-LCM4 requires only 5 VDC power, which can be supplied by the Opto 22 SNAP-PS5 power supply. The amount of current required depends upon the M4BUS expansion cards installed (see page 2); the controller itself requires 1.0 amp.

Memory

The RAM is used to store a user's control strategy (program) and data. The flash memory (EEPROM) stores the operating system firmware (kernel) and can also be used to store a control strategy. Memory is not expandable.

RAM: 4 MB (not expandable)

Flash EEPROM: 2 MB (not expandable)

Mounting

For DIN-rail mounting, also order a DIN clip package, part number SNAP-LCM4DIN.

Specifications

Item	Specification
CPU	32-bit Motorola processor IEEE floating-point math co-processor
Memory RAM Flash EEPROM	4 MB with battery backup (user programs and data), not expandable 2 MB (controller firmware and user programs), not expandable
RAM/clock battery	3.6-volt lithium, non-rechargeable
Communication, base unit	Three RS-232 or RS-485 ports, one dedicated RS-485 remote I/O port with interrupt capability
Real-time clock	Clock/calendar, Epson 64613 with battery backup, Y2K compliant
Power requirements	5VDC \pm 0.1 VDC at 1 Amp (maximum) without expansion cards
Typical operating temperature	0° C to 60° C
Storage temperature	-40° C to 85° C
Humidity	5% to 95% relative humidity, non-condensing
Software	FactoryFloor (OptoControl, OptoDisplay, OptoServer, and OptoConnect) and Classic software (Cyrano, Mystic MMI, and MDS)
Hard system monitors (including watchdog timer and voltage monitor)	Detect main power supply operation and proper microprocessor operation
Soft system monitors	Program/data corruption Host and I/O communication

SNAP-LCM4 System Architecture

The SNAP-LCM4 provides a variety of communication options, shown in the diagrams on this and the following page.

Ethernet Network

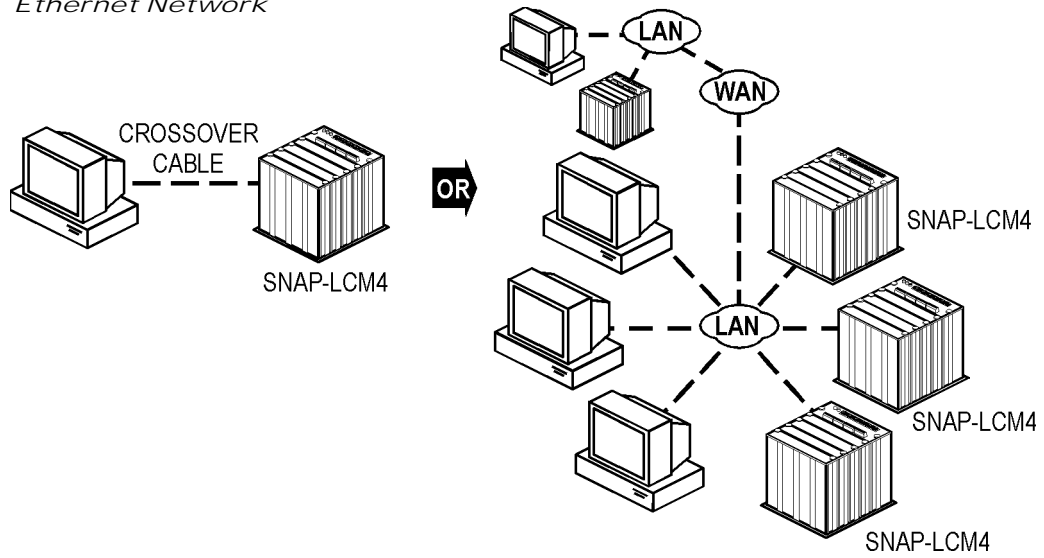

Serial Direct Connection

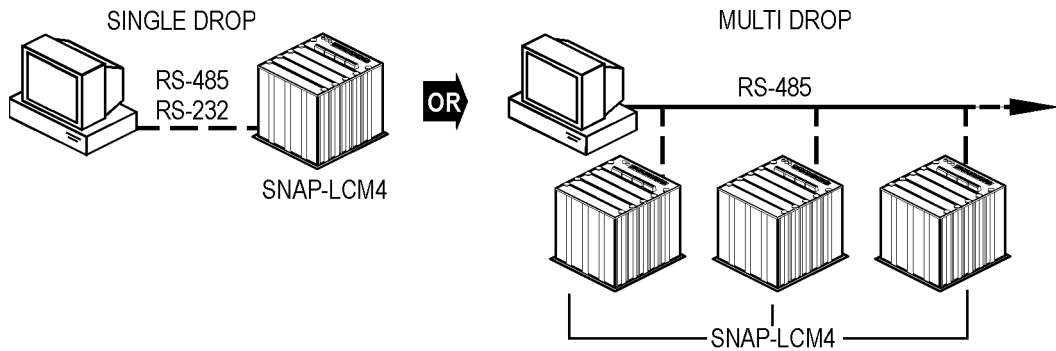

SNAP-LCM4 System Architecture (continued)

ARCNET Network

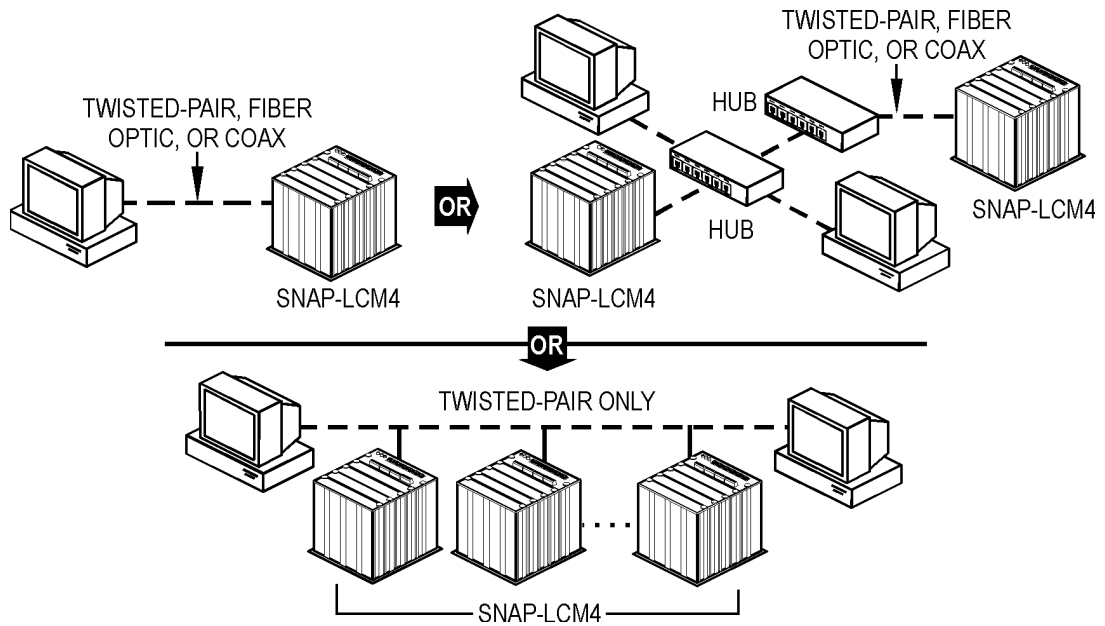

Remote Communication

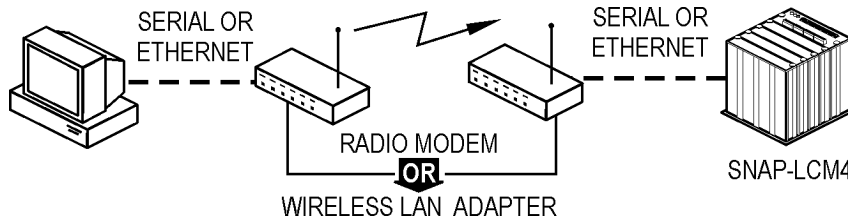

SNAP-LCM4 Dimensions (Panel Mounted)

For installation instructions, see Opto 22 Form 1122, *SNAP-LCM4 Installation Guide*.

Top View

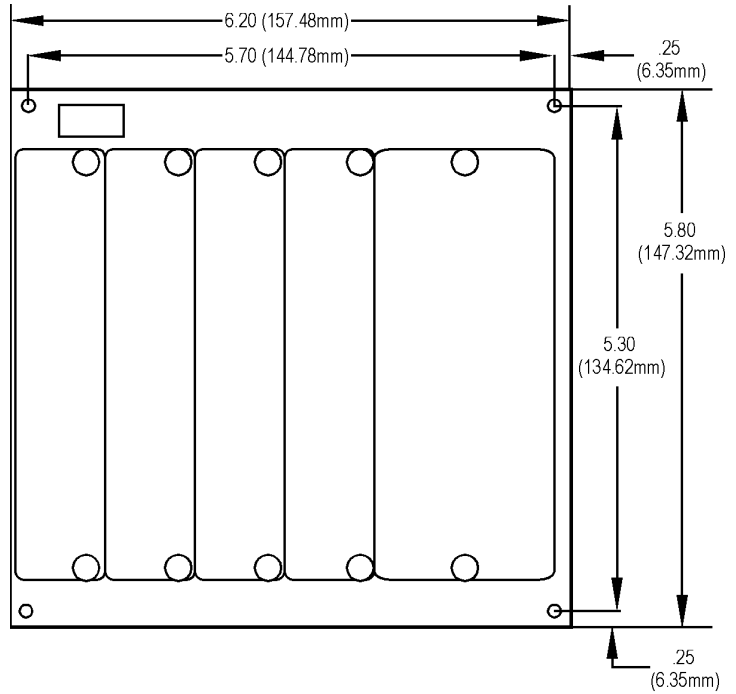

Side A View

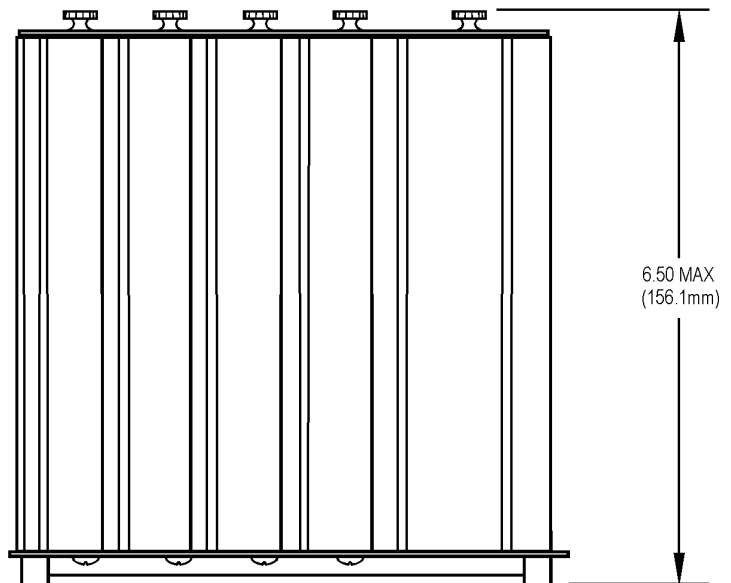

SNAP-LCM4 Dimensions (DIN-Rail Mounted)

Side B View

DIN-rail mounting requires a DIN clip package, part number SNAP-LCM4DIN (not included). For installation instructions, see Opto 22 Form 1122, *SNAP-LCM4 Installation Guide*.

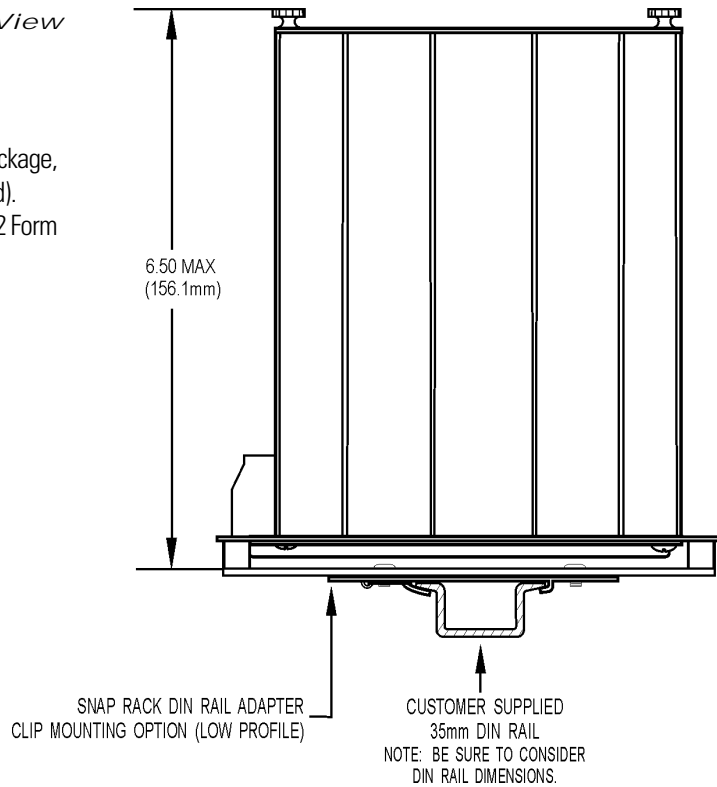

More About Opto 22

Products

Opto 22 develops and manufactures reliable, flexible, easy-to-use hardware and software products for industrial automation, remote monitoring, and data acquisition applications.

SNAP PAC System

Designed to simplify the typically complex process of understanding, selecting, buying, and applying an automation system, the SNAP PAC System consists of four integrated components:

- SNAP PAC controllers
- PAC Project™ Software Suite
- SNAP PAC brains
- SNAP I/O™

SNAP PAC Controllers

Programmable automation controllers (PACs) are multifunctional, multidomain, modular controllers based on open standards and providing an integrated development environment.

Opto 22 has been manufacturing PACs for many years. The latest models include the standalone SNAP PAC S-series and the rack-mounted SNAP PAC R-series. Both handle a wide range of digital, analog, and serial functions and are equally suited to data collection, remote monitoring, process control, and discrete and hybrid manufacturing.

SNAP PACs are based on open Ethernet and Internet Protocol (IP) standards, so you can build or extend a system without the expense and limitations of proprietary networks and protocols.

PAC Project Software Suite

Opto 22's PAC Project Software Suite provides full-featured and cost-effective control programming, HMI (human machine interface) development and runtime, OPC server, and database connectivity software to power your SNAP PAC System.

These fully integrated software applications share a single tagname database, so the data points you configure in PAC Control™ are immediately available for use in PAC Display™, OptoOPCServer™, and OptoDataLink™. Commands are in plain English; variables and I/O point names are fully descriptive.

PAC Project Basic offers control and HMI tools and is free for download on our website, www.opto22.com. PAC Project Professional, available for separate purchase, adds OptoOPCServer, OptoDataLink, options for Ethernet link redundancy or segmented networking, and support for legacy Opto 22 serial *mistic*™ I/O units.

SNAP PAC Brains

While SNAP PAC controllers provide central control and data distribution, SNAP PAC brains provide distributed intelligence for I/O processing and communications. Brains offer analog, digital, and serial functions, including thermocouple linearization; PID loop control; and optional high-speed digital counting (up to 20 kHz), quadrature counting, TPO, and pulse generation and measurement.

SNAP I/O

I/O provides the local connection to sensors and equipment. Opto 22 SNAP I/O offers 1 to 32 points of reliable I/O per module, depending on the type of module and your needs. Analog, digital, serial, and special-purpose modules are all mixed on the same mounting rack and controlled by the same processor (SNAP PAC brain or rack-mounted controller).

Quality

Founded in 1974 and with over 85 million devices sold, Opto 22 has established a worldwide reputation for high-quality products. All are made in the U.S.A. at our manufacturing facility in Temecula, California. Because we do no statistical testing and each part is tested twice before leaving our factory, we can guarantee most solid-state relays and optically isolated I/O modules for life.

Free Product Support

Opto 22's Product Support Group offers free, comprehensive technical support for Opto 22 products. Our staff of support engineers represents decades of training and experience. Product support is available in English and Spanish, by phone or email, Monday through Friday, 7 a.m. to 5 p.m. PST.

Free Customer Training

Hands-on training classes for the SNAP PAC System are offered at our headquarters in Temecula, California. Each student has his or her own learning station; classes are limited to nine students. Registration for the free training class is on a first-come, first-served basis. See our website, www.opto22.com, for more information or email training@opto22.com.

Purchasing Opto 22 Products

Opto 22 products are sold directly and through a worldwide network of distributors, partners, and system integrators. For more information, contact Opto 22 headquarters at 800-321-6786 or 951-695-3000, or visit our website at www.opto22.com.

www.opto22.com