



PART NO.

BC2 Series

REVISIONS

| ECN # | REV | DESCRIPTION | DRAWN | DATE    | CHECKD | DATE    | APPRVD | DATE    |
|-------|-----|-------------|-------|---------|--------|---------|--------|---------|
| -     | A   | RELEASED    | Veena | 31/5/05 | Shashi | 31/5/05 | NK     | 14/6/05 |

Features:

- Hand Held Case with Battery Compartment and Battery Clip/Pocket Clip Option.
- Moulded in high-impact Black, White or Grey ABS with integral PP3 battery - compartment accessible by a separate removable cover.
- Clip-in battery terminals are supplied as standard.
- Textured finish.
- No visible fixing screws for excellent final product appearance.
- The pocket clip, if required, can be easily fixed to the case by the two self-tapping screws supplied.
- The two main halves of the case are held together by the two self-tapping screws which are concealed by the battery cover.
- Four integral location pegs and sockets will hold a PCB in place without any further fixing.
- The overall finish of the case is matt with highlighted feature panels making it ideal for personalised products.

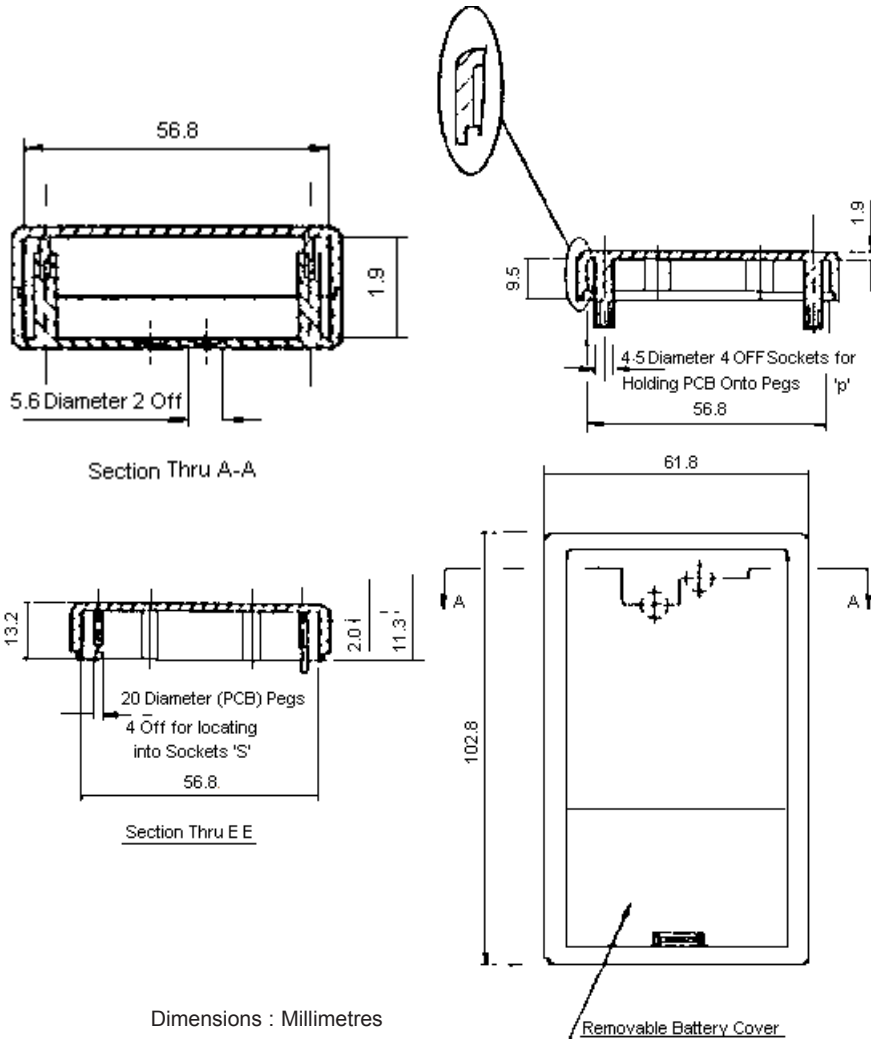

This data sheet and its contents (the "Information") belong to the Premier Farnell Group (the "Group") or are licensed to it. No licence is granted for the use of it other than for information purposes in connection with the products to which it relates. No licence of any intellectual property rights is granted. The Information is subject to change without notice and replaces all data sheets previously supplied. The Information supplied is believed to be accurate but the Group assumes no responsibility for its accuracy or completeness, any error in or omission from it or for any use made of it. Users of this data sheet should check for themselves the Information and the suitability of the products for their purpose and not make any assumptions based on information included or omitted. Liability for loss or damage resulting from any reliance on the Information or use of it (including liability resulting from negligence or where the Group was aware of the possibility of such loss or damage arising) is excluded. This will not operate to limit or restrict the Group's liability for death or personal injury resulting from its negligence. MULTICOMP is the registered trademark of the Group. © Premier Farnell plc 2004.

TOLERANCES:

UNLESS OTHERWISE SPECIFIED, DIMENSIONS ARE FOR REFERENCE PURPOSES ONLY.

|              |          |
|--------------|----------|
| DRAWN BY:    | DATE:    |
| Veena        | 31/05/05 |
| CHECKED BY:  | DATE:    |
| Shashi       | 31/05/05 |
| APPROVED BY: | DATE:    |
| NK           | 14/06/05 |

DRAWING TITLE:

BC2 Series - Miniature, Case

|            |             |                 |     |
|------------|-------------|-----------------|-----|
| SIZE       | DWG NO.     | ELECTRONIC FILE | REV |
| A          | M1000000138 | 23408_DWG       |     |
| SCALE: NTS | U.O.M.: mm  | SHEET: 1 OF 4   |     |



PART NO.

BC2 Series

REVISIONS

| ECN # | REV | DESCRIPTION | DRAWN | DATE    | CHECKD | DATE    | APPRVD | DATE    |
|-------|-----|-------------|-------|---------|--------|---------|--------|---------|
| -     | A   | RELEASED    | Veena | 31/5/05 | Shashi | 31/5/05 | NK     | 14/6/05 |

**ABS Polymers Specification  
Acrylonitrile-Butadiene-Styrene**

| Properties  | Test Method               | Unit              | Impact Resistant Grades |
|---|---------------------------|-------------------|-------------------------|
|   |                           |                   | 103                     |
| Izod Impact Strength +23°C<br>-20°C                   | ISO 180/3A<br>ASTM D256/A | kJ/m <sup>2</sup> | 17<br>11                |
| Tensile Strength at Yield                             | ISO R527<br>ASTM D638     | N/mm <sup>2</sup> | 50                      |
| Elongation at Yield                                   | ISO R527<br>ASTM D638     | %                 | 6                       |
| Flexural Strength                                     | ISO 178<br>ASTM D790      | N/mm <sup>2</sup> | 87                      |
| Rockwell Hardness                                     | ISO 2039/2<br>ASTM D785   | R scale           | 112                     |
| Heat Deflection Temperature<br>Unannealed<br>Annealed | ISO 75/A<br>ASTM D648     | °C                | 90<br>97                |
| Vicat Softening Temperature                           | ISO 306/B<br>ASTM D1525   | °C                | 97                      |
| Density   | ISO R1183<br>ASTM D792/A  | kg/m <sup>3</sup> | 1,050                   |
| Melt Flow Index                                       | ISO 1133<br>ASTM D1238    | dg/min            | 13                      |

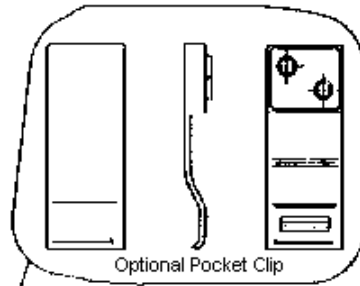

Optional Pocket Clip

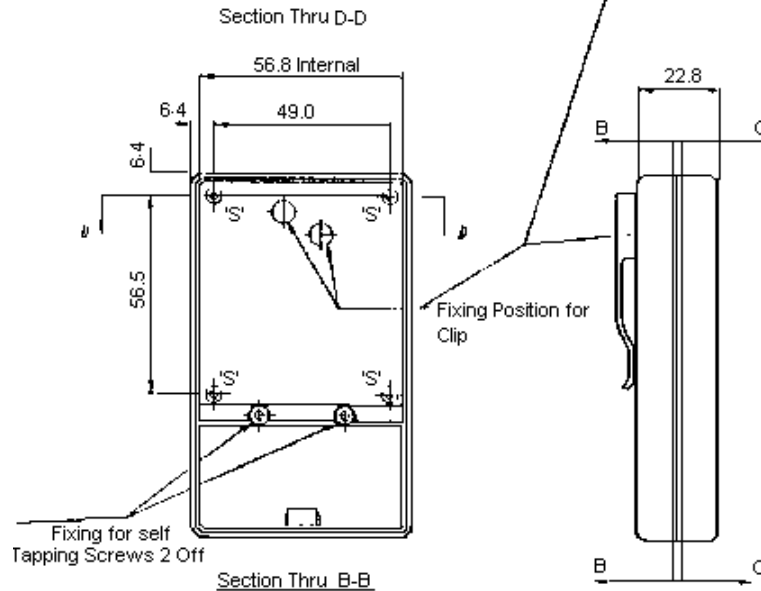

Dimensions : Millimetres

This data sheet and its contents (the "Information") belong to the Premier Farnell Group (the "Group") or are licensed to it. No licence is granted for the use of it other than for information purposes in connection with the products to which it relates. No licence of any intellectual property rights is granted. The Information is subject to change without notice and replaces all data sheets previously supplied. The Information supplied is believed to be accurate but the Group assumes no responsibility for its accuracy or completeness, any error in or omission from it or for any use made of it. Users of this data sheet should check for themselves the Information and the suitability of the products for their purpose and not make any assumptions based on information included or omitted. Liability for loss or damage resulting from any reliance on the Information or use of it (including liability resulting from negligence or where the Group was aware of the possibility of such loss or damage arising) is excluded. This will not operate to limit or restrict the Group's liability for death or personal injury resulting from its negligence. MULTICOMP is the registered trademark of the Group. © Premier Farnell plc 2004.

**TOLERANCES:**

**UNLESS OTHERWISE SPECIFIED, DIMENSIONS ARE FOR REFERENCE PURPOSES ONLY.**

|                     |              |
|---------------------|--------------|
| <b>DRAWN BY:</b>    | <b>DATE:</b> |
| Veena               | 31/05/05     |
| <b>CHECKED BY:</b>  | <b>DATE:</b> |
| Shashi              | 31/05/05     |
| <b>APPROVED BY:</b> | <b>DATE:</b> |
| NK                  | 14/06/05     |

**DRAWING TITLE:**

**BC2 Series - Miniature, Case**

|                   |                               |                                     |            |
|-------------------|-------------------------------|-------------------------------------|------------|
| <b>SIZE</b><br>A  | <b>DWG NO.</b><br>M1000000138 | <b>ELECTRONIC FILE</b><br>23408_DWG | <b>REV</b> |
| <b>SCALE: NTS</b> | <b>U.O.M.: mm</b>             | <b>SHEET: 2 OF 4</b>                |            |



PART NO.

BC2 Series

REVISIONS

| ECN # | REV | DESCRIPTION | DRAWN | DATE    | CHECKD | DATE    | APPRVD | DATE    |
|-------|-----|-------------|-------|---------|--------|---------|--------|---------|
| -     | A   | RELEASED    | Veena | 31/5/05 | Shashi | 31/5/05 | NK     | 14/6/05 |

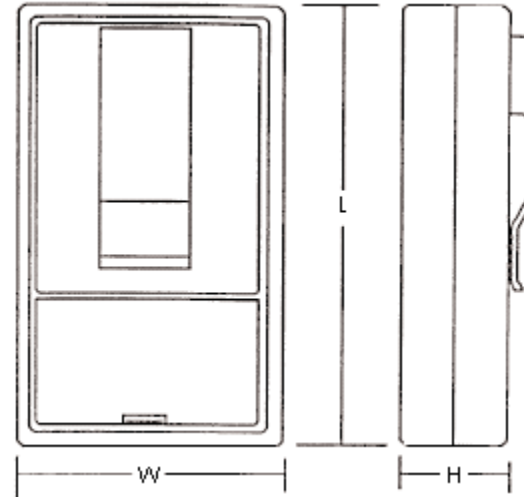
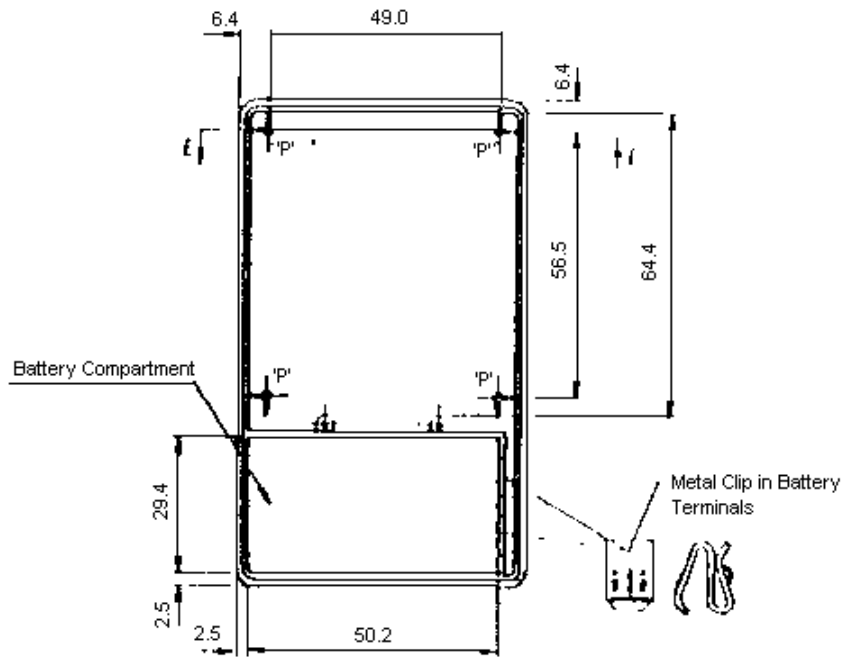

Section Thru C C

Dimensions : Millimetres

Part Number Table

| Colour         | External Dimensions |           |            |                  | Part Number |
|----------------|---------------------|-----------|------------|------------------|-------------|
|                | Length (L)          | Width (W) | Height (H) | Maximum PCB Size |             |
| Black          | 103                 | 62        | 23         | 64 x 56          | BC2         |
| Grey (RAL9002) |                     |           |            |                  | BC2LG       |
| White          |                     |           |            |                  | BC2W        |

Dimensions : Millimetres

This data sheet and its contents (the "Information") belong to the Premier Farnell Group (the "Group") or are licensed to it. No licence is granted for the use of it other than for information purposes in connection with the products to which it relates. No licence of any intellectual property rights is granted. The Information is subject to change without notice and replaces all data sheets previously supplied. The Information supplied is believed to be accurate but the Group assumes no responsibility for its accuracy or completeness, any error in or omission from it or for any use made of it. Users of this data sheet should check for themselves the information and the suitability of the products for their purpose and not make any assumptions based on information included or omitted. Liability for loss or damage resulting from any reliance on the Information or use of it (including liability resulting from negligence or where the Group was aware of the possibility of such loss or damage arising) is excluded. This will not operate to limit or restrict the Group's liability for death or personal injury resulting from its negligence. MULTICOMP is the registered trademark of the Group. © Premier Farnell plc 2004.

**TOLERANCES:**  
**UNLESS OTHERWISE SPECIFIED, DIMENSIONS ARE FOR REFERENCE PURPOSES ONLY.**

|                     |              |
|---------------------|--------------|
| <b>DRAWN BY:</b>    | <b>DATE:</b> |
| Veena               | 31/05/05     |
| <b>CHECKED BY:</b>  | <b>DATE:</b> |
| Shashi              | 31/05/05     |
| <b>APPROVED BY:</b> | <b>DATE:</b> |
| NK                  | 14/06/05     |

**DRAWING TITLE:**

**BC2 Series - Miniature, Case**

|                   |                               |                                     |                      |
|-------------------|-------------------------------|-------------------------------------|----------------------|
| <b>SIZE</b><br>A  | <b>DWG NO.</b><br>M1000000138 | <b>ELECTRONIC FILE</b><br>23408_DWG | <b>REV</b>           |
| <b>SCALE: NTS</b> |                               | <b>U.O.M.: mm</b>                   | <b>SHEET: 3 OF 4</b> |



PART NO.

BC2 Series

REVISIONS

| ECN # | REV | DESCRIPTION | DRAWN | DATE    | CHECKD | DATE    | APPRVD | DATE    |
|-------|-----|-------------|-------|---------|--------|---------|--------|---------|
| -     | A   | RELEASED    | Veena | 31/5/05 | Shashi | 31/5/05 | NK     | 14/6/05 |

Notes:

International Sales Offices:

- AUSTRALIA - Farnell InOne**  
Tel No: ++ 61 2 9645 8888  
Fax No: ++ 61 2 9644 7898
- AUSTRIA - Farnell InOne**  
Tel No: ++ 43 662 2180 680  
Fax No: ++ 43 662 2180 670
- BELGIUM - Farnell InOne**  
Tel No: ++ 32 3 475 2810  
Fax No: ++ 32 3 227 3648
- BRAZIL - Farnell-Newark InOne**  
Tel No: ++ 55 11 4066 9400  
Fax No: ++ 55 11 4066 9410
- CHINA - Farnell-Newark InOne**  
Tel No: ++86 10 6238 5152  
Fax No: ++86 10 6238 5022
- DENMARK - Farnell InOne**  
Tel No: ++ 45 44 53 66 44  
Fax No: ++ 45 44 53 66 06
- ESTONIA - Farnell InOne**  
Tel No: ++ 358 9 560 7780  
Fax No: ++ 358 9 345 5411
- FINLAND - Farnell InOne**  
Tel No: ++ 358 9 560 7780  
Fax No: ++ 358 9 345 5411
- FRANCE - Farnell InOne**  
Tel No: ++ 33 474 68 99 99  
Fax No: ++ 33 474 68 99 90
- GERMANY - Farnell InOne**  
Tel No: ++ 49 89 61 39 39 39  
Fax No: ++ 49 89 613 59 01
- HONG KONG - Farnell-Newark InOne**  
Tel No: ++ 852 2268 9888  
Fax No: ++ 852 2268 9899
- IRELAND - Farnell InOne**  
Tel No: ++ 353 1 830 9277  
Fax No: ++ 353 1 830 9016
- ITALY - Farnell InOne**  
Tel No: ++ 39 02 93 995 200  
Fax No: ++ 39 02 93 995 300
- MALAYSIA - Farnell-Newark InOne**  
Tel No: ++ 60 3 7873 8000  
Fax No: ++ 60 3 7873 7000
- NETHERLANDS - Farnell InOne**  
Tel No: ++ 31 30 241 7373  
Fax No: ++ 31 30 241 7333
- NORWAY - Farnell InOne**  
Tel No: ++ 45 44 53 66 66  
Fax No: ++ 45 44 53 66 02
- PORTUGAL - Farnell InOne**  
Tel No: ++ 34 93 475 8804  
Fax No: ++ 34 93 474 5288
- SINGAPORE - Farnell-Newark InOne**  
Tel No: ++ 65 6788 0200  
Fax No: ++ 65 6788 0300
- SPAIN - Farnell InOne**  
Tel No: ++ 34 93 475 8805  
Fax No: ++ 34 93 474 5107
- SWEDEN - Farnell InOne**  
Tel No: ++ 46 8 730 50 00  
Fax No: ++ 46 8 83 52 62
- SWITZERLAND - Farnell InOne**  
Tel No: ++ 41 1 204 64 64  
Fax No: ++ 41 1 204 64 54
- UK - Farnell InOne**  
Tel No: ++ 44 8701 200 200  
Fax No: ++ 44 8701 200 201
- UK - BuckHickman InOne**  
++ 44 8450 510 150  
++ 44 8450 510 130
- UK - CPC**  
++ 44 8701 202 530  
++ 44 8701 202 531

**export** EXPORT - Farnell InOne  
Tel No: ++ 44 8701 200 208  
Fax No: ++ 44 8701 200 209  
For enquiries from all other markets

- <http://www.farnellinone.com>
- <http://www.buckhickmaninone.com>
- <http://www.cpc.co.uk>

This data sheet and its contents (the "Information") belong to the Premier Farnell Group (the "Group") or are licensed to it. No licence is granted for the use of it other than for information purposes in connection with the products to which it relates. No licence of any intellectual property rights is granted. The Information is subject to change without notice and replaces all data sheets previously supplied. The Information supplied is believed to be accurate but the Group assumes no responsibility for its accuracy or completeness, any error in or omission from it or for any use made of it. Users of this data sheet should check for themselves the Information and the suitability of the products for their purpose and not make any assumptions based on information included or omitted. Liability for loss or damage resulting from any reliance on the Information or use of it (including liability resulting from negligence or where the Group was aware of the possibility of such loss or damage arising) is excluded. This will not operate to limit or restrict the Group's liability for death or personal injury resulting from its negligence. MULTICOMP is the registered trademark of the Group. © Premier Farnell plc 2004.

**TOLERANCES:**  
**UNLESS OTHERWISE SPECIFIED, DIMENSIONS ARE FOR REFERENCE PURPOSES ONLY.**

|                     |              |
|---------------------|--------------|
| <b>DRAWN BY:</b>    | <b>DATE:</b> |
| Veena               | 31/05/05     |
| <b>CHECKED BY:</b>  | <b>DATE:</b> |
| Shashi              | 31/05/05     |
| <b>APPROVED BY:</b> | <b>DATE:</b> |
| NK                  | 14/06/05     |

|                                     |                    |                        |                      |
|-------------------------------------|--------------------|------------------------|----------------------|
| <b>DRAWING TITLE:</b>               |                    |                        |                      |
| <b>BC2 Series - Miniature, Case</b> |                    |                        |                      |
| <b>SIZE</b>                         | <b>DWG NO.</b>     | <b>ELECTRONIC FILE</b> | <b>REV</b>           |
| <b>A</b>                            | <b>M1000000138</b> | <b>23408_DWG</b>       |                      |
| <b>SCALE: NTS</b>                   |                    | <b>U.O.M.: mm</b>      | <b>SHEET: 4 OF 4</b> |