

Emergency Lighting Systems and Battery Powered Fluorescent Lighting

High Current TO92 Switching Transistors Provide 87% DC-AC Conversion Efficiency

David Bradbury
Neil Chadderton

Introduction

Emergency lighting systems are frequently employed as a required safety feature within business premises. These systems comprise essentially of a control circuit, a battery pack, a trickle charging circuit, and either an in-built incandescent lamp, or an inverter that will allow the battery supply to drive the existing fluorescent tubes. It is the latter version, and the requisite DC-AC inverter that are addressed within this application note.

Figure 1 presents a block diagram of a typical emergency lighting system. The control circuit monitors the mains supply, and if all is well, allows the charger to trickle charge the battery pack. In the event of the mains voltage failing, the controller then enables the inverter which provides sufficient power to a fluorescent tube to provide illumination.

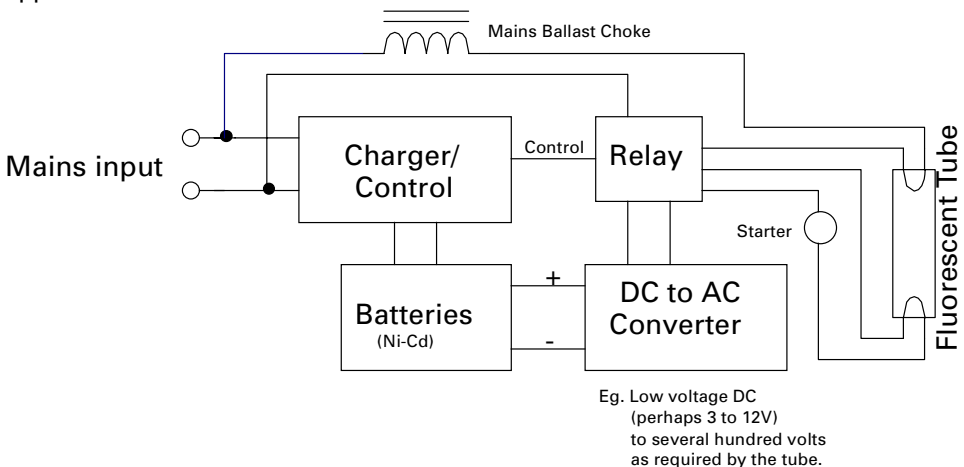

Figure 1
Typical Emergency Lighting System Schematic.

It should be noted that this tube is quite often a standard ceiling tube that would be otherwise powered by the mains supply.

Closely allied to this application, and indeed where similar circuits are employed, are illumination signs for entrance, exits and walkways.

Fluorescent tubes are employed in these applications because they are many times more efficient at converting electrical energy into light than conventional incandescent bulbs. This efficiency translates directly into extended battery life.

The number of series connected cells used in an emergency lighting system is kept to a minimum to optimise storage efficiency, reliability and cost. The resultant low output voltage of the battery pack does however make it more difficult to design high efficiency converters.

Battery powered fluorescent lighting is an important application area that significantly benefits from the very low saturation voltage exhibited by the ZTX688B, ZTX689B and ZTX869 transistors developed by Zetex. Housed in the E-Line (TO92 style) package, these transistors replace the TO126 and TO220 types commonly used in this application, giving savings in cost and size whilst providing improvements in efficiency too. All three types use a variant of the Zetex pioneered Matrix geometry and exhibit very high current gain due to a Super- β emitter process, which allows power savings in the base drive required.



Figure 2
Current vs Voltage Characteristics for 8W
Linear Fluorescent Tube.

Fluorescent Tube Characteristics

Figure 2 shows the V-I characteristics of an 8W fluorescent tube before and after striking. (An 8W tube being a common unit in illuminated door signs for example). Note that during striking the tube requires a peak voltage of approximately 200-300V before conducting, yet once struck and warm the tube blocks around 50V at normal operating current. Using a single output voltage converter to both initiate tube striking and to supply the tube subsequently, a loss-less dropper must be employed to absorb the large change in operating voltage. In 50Hz main lamps an inductor is used, but if the AC supply is generated at a high frequency then a capacitor makes a smaller and cheaper alternative. Operating the lamp at a high frequency also gives efficiency benefits. Tubes working at 25kHz can give up to 15% more light output for the same input energy .

The striking voltage of the tube increases both with age and decreasing temperature - so the open circuit output voltage of the converter needs to be set to around 500V (or higher, dependent on tube dimensions and characteristics) for reliable operation. The ballast capacitor value must be set to source about 120mA to supply the full tube power. In many emergency lighting systems, the output power of the inverter (and therefore the light output of the tube) is limited so to provide a longer operating time from the available energy source.

The circuits presented in this note however have been designed to operate at an output power of 8W. This serves to demonstrate the capability of the transistors and the basic topology, and can be used as a starting point for development of lighting inverters for a customer's specific application.

High Efficiency DC-AC Converters

The high voltage AC supply required by the fluorescent tube is generated using

a push pull switching converter forced to run in synchronised mode by the inclusion of a supply inductor. This converter topology is also known as a resonant version of the popular push-pull power inverter developed by George Royer, and so is often termed a "Royer" Converter.

The following describes two fluorescent lamp circuits, both for 8W output, but designed for different input voltage ranges. Both circuits enable very high conversion efficiency. Each is designed to operate from just two series connected cells, either lead acid types providing 4V nominal or Ni-Cd/Ni-MH types at 2.4V. The same basic circuit is used for both voltage variants, but the component and transformer details are adjusted accordingly.

The circuit shown in Figure 3 can be used for the 2.4V or 4V supplies by selecting the appropriate component values from Table 1, or modified for any other supply voltage by consideration of the required transformer turns ratio.

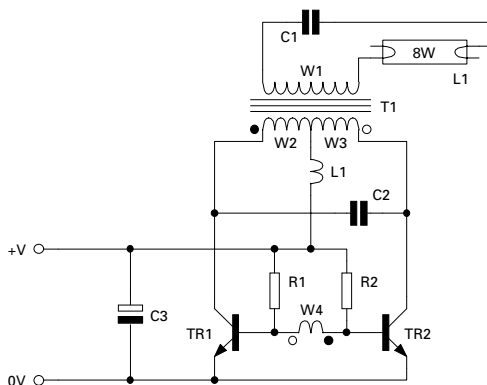

Figure 3
Resonant Push-pull Inverter for Low DC to High AC Voltage Inversion.

+V	2.4 Volts	4 Volts
R1	120Ω 0.5W	120Ω 0.5W
R2	120Ω 0.5W	120Ω 0.5W
TR1	ZTX869	ZTX689B or ZTX869
TR2	ZTX869	ZTX689B or ZTX869
C1	2.2nF 1000V Polypropylene	2.2nF 1000V Polypropylene
C2	0.47μF 100V Polyester	0.15μF 100V Polyester
C3	100μF 6.3V Electrolytic	100μF 6.3V Electrolytic
L1	25μH (25T, 1mm copper wire on 9mm dia 25mm long ferrite rod.)	60μH (35T, 0.71mm copper wire on 9mm dia 25mm long ferrite rod.)
T1	FX3440 cores with 0.55 spacer or FX 3670 cores with 0.65mm spacer. DT2484 coil former	FX3440 cores with 0.34 spacer or FX 3670 cores with 0.45mm spacer. DT2484 coil former
W1	500T 0.18mm neatly wound (first winding)	400T 0.18mm neatly wound (first winding)
W2 & W3	3T each, 0.5mm Bifilar wound (second and third windings)	4T each, 0.5mm Bifilar wound (second and third windings)
W4	3T 0.31mm (fourth winding)	3T 0.31mm (fourth winding)

NOTE: Use insulating tape between W1 and other windings. Core spacer must be made from a non-conducting material.

Table1
Component values for 2.4V and 4V Nominal Supply Fluorescent lamp Inverters.

The output voltage of the inverters has been set to approximately 560V peak, to provide the capability of striking tubes for low input voltage supplies. The 4V design for example, will strike tubes down to a 2.2V input, and once struck the lamp will continue to work for supplies down to 1.5V. During normal running, the operating frequency of 25kHz is set by the output capacitor C1 and the inductance of the transformer secondary winding W1. Before striking, or in the event of the tube being broken or removed, capacitor C2 and the

transformer primary windings W2 & W3 set the oscillation frequency to a safe 120kHz where the circuit can run indefinitely without harm.

The voltage across each switching transistor when driven off (by the feedback winding) is a half wave sinusoid with a peak value of $\pi \times V_s$. The collector current when the device is on is fairly square with a ripple at twice the frequency of oscillation, controlled by the value of the series inductor L1. Figures 4 and 5 show these waveforms.

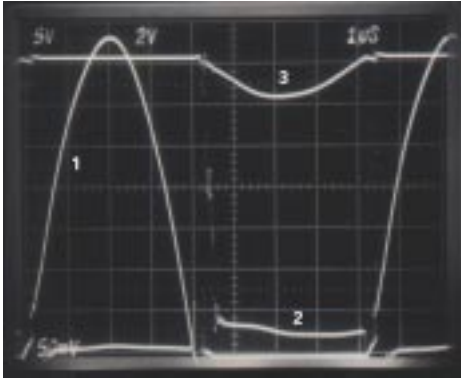

Figure 4
Inverter Operating waveforms for No Load
1. V_{CE} , 2. I_E , and 3. V_{BE} ,
2V/div, 0.5A/div and 5V/div respectively.
 $F_{op} \approx 120\text{kHz}$.

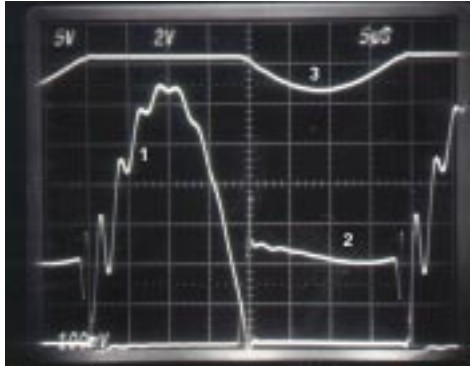

Figure 5
Inverter Operating waveforms for 8W
Fluorescent Tube Load
1. V_{CE} , 2. I_E , and 3. V_{BE} .
2V/div, 1A/div and 5V/div respectively.
 $F_{op} \approx 30\text{kHz}$.

As the supply voltage is so small, low saturation voltage is critical in achieving good efficiency from the converter.

The designs have been optimised to meet the following key factors:-

1. Cost The designs operate from just two series connected Ni-Cd/Ni-MH or lead-acid cells - the less cells that are used in a battery pack, the cheaper and more volume efficient it will be. Also, replacing the TO220 type transistors normally used with E-Line ZTX689B or ZTX869 transistors reduces component and board size.

2. Battery Life The ZTX689B and ZTX869 transistors give by far the lowest saturation voltage of devices in their class. This translates directly to

improved circuit efficiency and extended battery life. With most of the remaining losses occurring in the wound components, the efficiency of the 4V design is around 87% and the 2.4V design a very creditable 82%.

3. Supply Operating Range The 4V design will work for battery voltages in the range of 1.5V up to 8V. The 2.4V design from 0.95V to 6V. These wide operating ranges means that the circuits will withstand the high supply voltage that can occur with rapid charging, yet are capable of wringing the last ounce of charge from failing battery packs.

4. Reliability The designs give an enhanced reliability in several areas. The low power losses of the ZTX689B & ZTX869 transistors minimise

temperature rises in the converter - important in reliability terms. Eliminating the bulk of TO126 or TO220 type transistors removes potential susceptibility to vibration. Also the circuits will withstand reverse battery connection and indefinite operation without a fluorescent tube - important in un-attended applications.

The designs operate at a frequency of around 100kHz during striking, falling to 25kHz once struck. The circuits give an instant start characteristic as no heater warm up time is required.

If necessary, the circuit can be adapted to operate from a single 2V cell. Other possible variants will drive higher wattage tubes at reduced power levels - giving emergency back-up of normally mains powered tubes.

Appendix

Partial Characterisation of ZTX688B. Full details available in the Through Hole Components Semiconductor Data Book available from your local ZETEX agent.

PARAMETER	SYMBOL	MIN.	TYP.	MAX.	UNIT	CONDITIONS.
Collector-Base Breakdown Voltage	$V_{(BR)CBO}$	12			V	$I_C=100\mu A$
Collector-Emitter Breakdown Voltage	$V_{(BR)CEO}$	12			V	$I_C=10mA^*$
Emitter-Base Breakdown Voltage	$V_{(BR)EBO}$	5			V	$I_E=100\mu A$
Collector Cut-Off Current	I_{CBO}			0.1	μA	$V_{CB}=10V$
Emitter Cut-Off Current	I_{EBO}			0.1	μA	$V_{EB}=4V$
Collector-Emitter Saturation Voltage	$V_{CE(sat)}$			0.04 0.06 0.18 0.35	V V V V	$I_C=0.1A, I_B=1mA$ $I_C=0.1A, I_B=0.5mA^*$ $I_C=1A, I_B=50mA^*$ $I_C=3A, I_B=20mA^*$
Base-Emitter Saturation Voltage	$V_{BE(sat)}$			1.1	V	$I_C=3A, I_B=20mA^*$
Base-Emitter Turn-On Voltage	$V_{BE(on)}$			1	V	$I_C=3A, V_{CE}=2V^*$
Static Forward Current Transfer Ratio	h_{FE}	500 400 100				$I_C=0.1A, V_{CE}=2V^*$ $I_C=3A, V_{CE}=2V^*$ $I_C=10A, V_{CE}=2V^*$
Transition Frequency	f_T	150			MHz	$I_C=50mA, V_{CE}=5V$ $f=50MHz$
Input Capacitance	C_{ibo}		200		pF	$V_{EB}=0.5V, f=1MHz$
Output Capacitance	C_{obo}		40		pF	$V_{CB}=10V, f=1MHz$

*Measured under pulsed conditions. Pulse width=300 μs . Duty cycle $\leq 2\%$