

## FEATURES

- Operating Power-Supply Voltage Range of 1.65 V to 5.5 V
- Allows Bidirectional Voltage-Level Translation and GPIO Expansion Between
  - 1.8-V SCL/SDA and 1.8-V, 2.5-V, 3.3-V, or 5-V P Port
  - 2.5-V SCL/SDA and 1.8-V, 2.5-V, 3.3-V, or 5-V P Port
  - 3.3-V SCL/SDA and 1.8-V, 2.5-V, 3.3-V, or 5-V P Port
  - 5-V SCL/SDA and 1.8-V, 2.5-V, 3.3-V, or 5-V P Port
- I<sup>2</sup>C to Parallel Port Expander
- Low Standby Current Consumption of 1  $\mu$ A
- Schmitt-Trigger Action Allows Slow Input Transition and Better Switching Noise Immunity at the SCL and SDA Inputs
  - $V_{hys} = 0.18$  V Typ at 1.8 V
  - $V_{hys} = 0.25$  V Typ at 2.5 V
  - $V_{hys} = 0.33$  V Typ at 3.3 V
  - $V_{hys} = 0.5$  V Typ at 5 V
- 5-V Tolerant I/O Ports
- Active-Low Reset Input ( $\overline{RESET}$ )
- Open-Drain Active-Low Interrupt Output ( $\overline{INT}$ )
- 400-kHz Fast I<sup>2</sup>C Bus
- Input/Output Configuration Register
- Polarity Inversion Register
- Internal Power-On Reset
- Power-Up With All Channels Configured as Inputs
- No Glitch On Power-Up
- Noise Filter on SCL/SDA Inputs
- Latched Outputs With High-Current Drive Maximum Capability for Directly Driving LEDs
- Latch-Up Performance Exceeds 100 mA Per JESD 78, Class II
- ESD Protection Exceeds JESD 22
  - 2000-V Human-Body Model (A114-A)
  - 200-V Machine Model (A115-A)
  - 1000-V Charged-Device Model (C101)

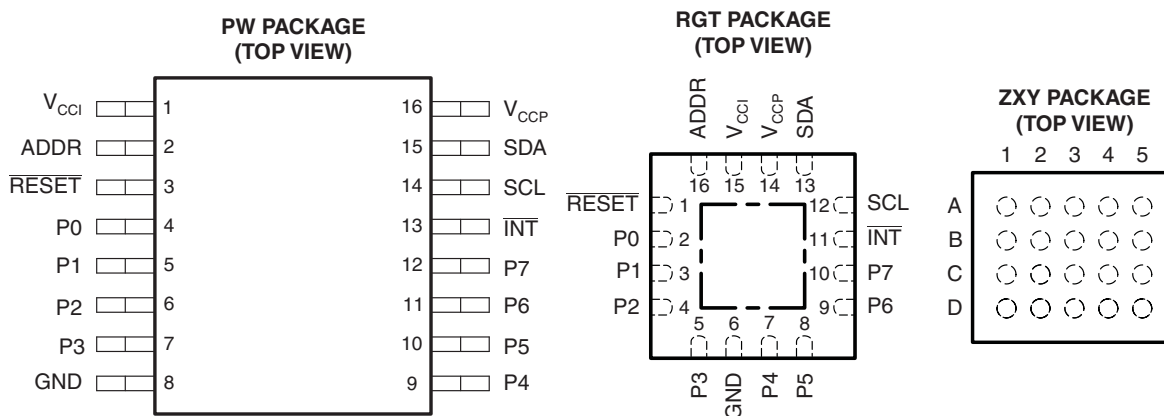

## DESCRIPTION/ORDERING INFORMATION

This 8-bit I/O expander for the two-line bidirectional bus (I<sup>2</sup>C) is designed to provide general-purpose remote I/O expansion for most microcontroller families via the I<sup>2</sup>C interface [serial clock (SCL) and serial data (SDA)].



Please be aware that an important notice concerning availability, standard warranty, and use in critical applications of Texas Instruments semiconductor products and disclaimers thereto appears at the end of this data sheet.

# TCA6408

## LOW-VOLTAGE 8-BIT I<sup>2</sup>C AND SMBus I/O EXPANDER WITH INTERRUPT OUTPUT, RESET, AND CONFIGURATION REGISTERS

SCPS151C—FEBRUARY 2007—REVISED JUNE 2007

### ORDERING INFORMATION

T <sub>A</sub>	PACKAGE <sup>(1)</sup>		ORDERABLE PART NUMBER	TOP-SIDE MARKING
-40°C to 85°C	QFN – RGT	Reel of 3000	TCA6408RGTR	ZWP
	BGA – ZXY (Pb-free)	Reel of 2500	TCA6408ZXYR	PH408
	TSSOP – PW	Tube of 70	TCA6408PW	PH408
		Reel of 2000	TCA6408PWR	

(1) For the most current package and ordering information, see the Package Option Addendum at the end of this document, or see the TI website at [www.ti.com](http://www.ti.com).

The major benefit of this device is its wide V<sub>CC</sub> range. It can operate from 1.65-V to 5.5-V on the P port side and on the SDA/SCL side. This allows the TCA6408 to interface with next-generation microprocessors and microcontrollers on the SDA/SCL side, where supply levels are dropping down to conserve power. In contrast to the dropping power supplies of microprocessors and microcontrollers, some PCB components such as LEDs remain at a 5-V power supply.

The bidirectional voltage level translation in the TCA6408 is provided through V<sub>CCI</sub>. V<sub>CCI</sub> should be connected to the V<sub>CC</sub> of the external SCL/SDA lines. This indicates the V<sub>CC</sub> level of the I<sup>2</sup>C bus to the TCA6408. The voltage level on the P port of the TCA6408 is determined by V<sub>CCP</sub>.

The TCA6408 consists of one 8-bit configuration (input or output selection), input, output, and polarity inversion (active high) register. At power on, the I/Os are configured as inputs. However, the system master can enable the I/Os as either inputs or outputs by writing to the I/O configuration bits. The data for each input or output is kept in the corresponding input or output register. The polarity of the input port register can be inverted with the polarity inversion register. All registers can be read by the system master.

The system master can reset the TCA6408 in the event of a timeout or other improper operation by asserting a low in the  $\overline{\text{RESET}}$  input. The power-on reset puts the registers in their default state and initializes the I<sup>2</sup>C/SMBus state machine. The  $\overline{\text{RESET}}$  pin causes the same reset/initialization to occur without depowering the part.

The TCA6408 open-drain interrupt ( $\overline{\text{INT}}$ ) output is activated when any input state differs from its corresponding input port register state and is used to indicate to the system master that an input state has changed.

$\overline{\text{INT}}$  can be connected to the interrupt input of a microcontroller. By sending an interrupt signal on this line, the remote I/O can inform the microcontroller if there is incoming data on its ports without having to communicate via the I<sup>2</sup>C bus. Thus, the TCA6408 can remain a simple slave device.

The device P port outputs have high-current sink capabilities for directly driving LEDs while consuming low device current.

One hardware pin (ADDR) can be used to program and vary the fixed I<sup>2</sup>C address and allow up to two devices to share the same I<sup>2</sup>C bus or SMBus.

### ZXY Terminal Assignments

	1	2	3	4	5
<b>A</b>	P3	P2	P1	$\overline{\text{RESET}}$	ADDR
<b>B</b>	GND	N.C. <sup>(1)</sup>	P0	N.C. <sup>(1)</sup>	V <sub>CCI</sub>
<b>C</b>	P4	N.C. <sup>(1)</sup>	$\overline{\text{INT}}$	N.C. <sup>(1)</sup>	V <sub>CCP</sub>
<b>D</b>	P5	P6	P7	SCL	SDA

(1) N.C. – No internal connection

### TERMINAL FUNCTIONS

PIN NUMBER			NAME	DESCRIPTION
TSSOP (PW)	QFN (RGT)	BGA (ZXY)		
1	15	B5	V <sub>CCI</sub>	Supply voltage of I <sup>2</sup> C bus. Connect directly to the V <sub>CC</sub> of the external I <sup>2</sup> C master. Provides voltage level translation.
2	16	A5	ADDR	Address input. Connect directly to V <sub>CCP</sub> or ground.
3	1	A4	$\overline{\text{RESET}}$	Active-low reset input. Connect to V <sub>CCP</sub> through a pullup resistor, if no active connection is used.
4	2	B3	P0	P port input/output (push-pull design structure). At power on, P0 is configured as an input.
5	3	A3	P1	P port input/output (push-pull design structure). At power on, P1 is configured as an input.
6	4	A2	P2	P port input/output (push-pull design structure). At power on, P2 is configured as an input.
7	5	A1	P3	P port input/output (push-pull design structure). At power on, P3 is configured as an input.
8	6	B1	GND	Ground
9	7	C1	P4	P port input/output (push-pull design structure). At power on, P4 is configured as an input.
10	8	D1	P5	P port input/output (push-pull design structure). At power on, P5 is configured as an input.
11	9	D2	P6	P port input/output (push-pull design structure). At power on, P6 is configured as an input.
12	10	D3	P7	P port input/output (push-pull design structure). At power on, P7 is configured as an input.
13	11	C3	$\overline{\text{INT}}$	Interrupt output. Connect to V <sub>CCI</sub> through a pullup resistor.
14	12	D4	SCL	Serial clock bus. Connect to V <sub>CCI</sub> through a pullup resistor.
15	13	D5	SDA	Serial data bus. Connect to V <sub>CCI</sub> through a pullup resistor.
16	14	C5	V <sub>CCP</sub>	Supply voltage of TCA6408 for P port.

# TCA6408 LOW-VOLTAGE 8-BIT I<sup>2</sup>C AND SMBus I/O EXPANDER WITH INTERRUPT OUTPUT, RESET, AND CONFIGURATION REGISTERS

SCPS151C—FEBRUARY 2007—REVISED JUNE 2007

## Voltage Translation

Table 1 shows how to set up  $V_{CC}$  levels for the necessary voltage translation between the I<sup>2</sup>C bus and the TCA6408.

Table 1. Voltage Translation

$V_{CC1}$ (SCL and SDA of I <sup>2</sup> C master) (V)	$V_{CCP}$ (P Port) (V)
1.8	1.8
1.8	2.5
1.8	3.3
1.8	5
2.5	1.8
2.5	2.5
2.5	3.3
2.5	5
3.3	1.8
3.3	2.5
3.3	3.3
3.3	5
5	1.8
5	2.5
5	3.3
5	5

**LOGIC DIAGRAM (POSITIVE LOGIC)**

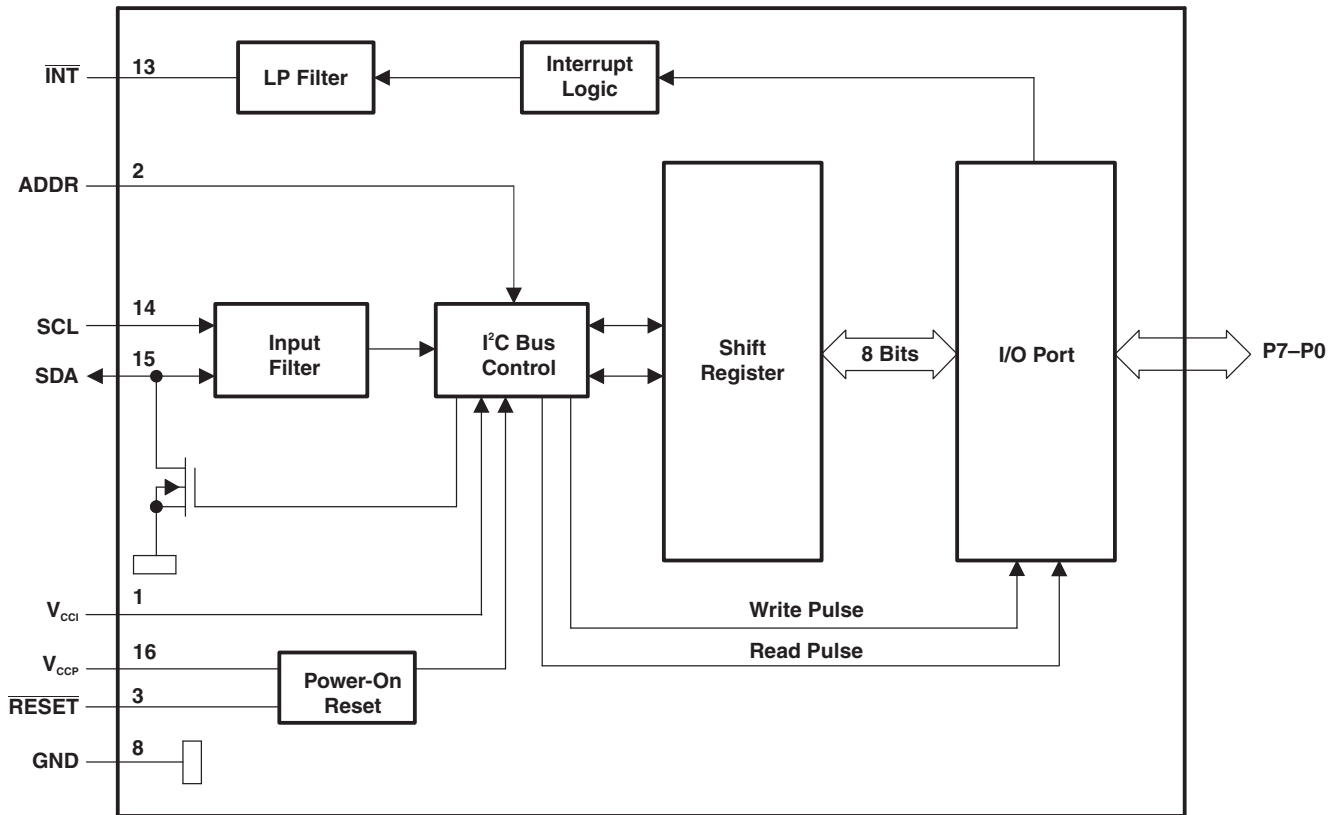

- A. All pin numbers shown are for the PW package.
- B. All I/Os are set to inputs at reset.

**Simplified Schematic of P0 to P7**

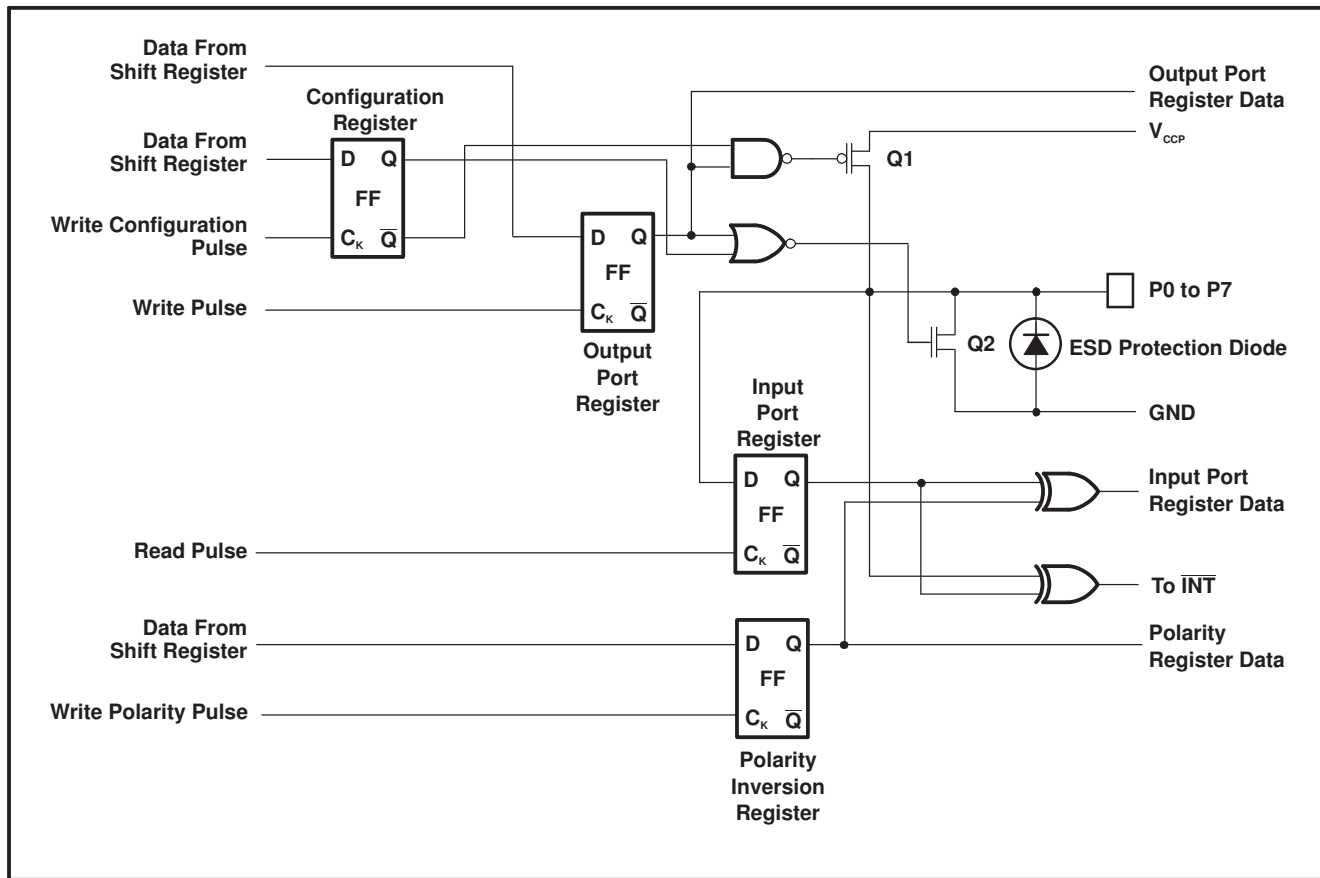

A. On power up or reset, all registers return to default values.

## I/O Port

When an I/O is configured as an input, FETs Q1 and Q2 are off, which creates a high-impedance input. The input voltage may be raised above V<sub>CC</sub> to a maximum of 5.5 V.

If the I/O is configured as an output, Q1 or Q2 is enabled depending on the state of the output port register. In this case, there are low impedance paths between the I/O pin and either V<sub>CC</sub> or GND. The external voltage applied to this I/O pin should not exceed the recommended levels for proper operation.

## I<sup>2</sup>C Interface

The bidirectional I<sup>2</sup>C bus consists of the serial clock (SCL) and serial data (SDA) lines. Both lines must be connected to a positive supply through a pullup resistor when connected to the output stages of a device. Data transfer may be initiated only when the bus is not busy.

I<sup>2</sup>C communication with this device is initiated by a master sending a start condition, a high-to-low transition on the SDA input/output, while the SCL input is high (see Figure 1). After the start condition, the device address byte is sent, MSB first, including the data direction bit (R/W).

After receiving the valid address byte, this device responds with an acknowledge (ACK), a low on the SDA input/output during the high of the ACK-related clock pulse. The address input (ADDR) of the slave device must not be changed between the start and the stop conditions.

On the I<sup>2</sup>C bus, only one data bit is transferred during each clock pulse. The data on the SDA line must remain stable during the high pulse of the clock period, as changes in the data line at this time are interpreted as control commands (start or stop) (see Figure 2).

A stop condition, a low-to-high transition on the SDA input/output while the SCL input is high, is sent by the master (see Figure 1).

Any number of data bytes can be transferred from the transmitter to receiver between the start and the stop conditions. Each byte of eight bits is followed by one ACK bit. The transmitter must release the SDA line before the receiver can send an ACK bit. The device that acknowledges must pull down the SDA line during the ACK clock pulse, so that the SDA line is stable low during the high pulse of the ACK-related clock period (see Figure 3). When a slave receiver is addressed, it must generate an ACK after each byte is received. Similarly, the master must generate an ACK after each byte that it receives from the slave transmitter. Setup and hold times must be met to ensure proper operation.

A master receiver signals an end of data to the slave transmitter by not generating an acknowledge (NACK) after the last byte has been clocked out of the slave. This is done by the master receiver by holding the SDA line high. In this event, the transmitter must release the data line to enable the master to generate a stop condition.

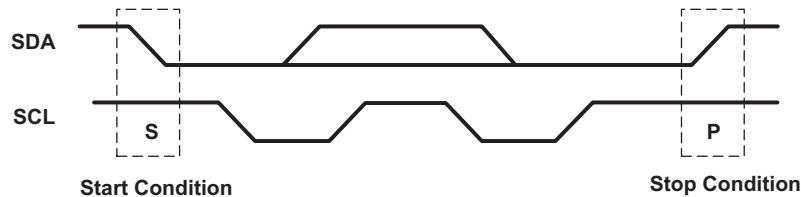

Figure 1. Definition of Start and Stop Conditions

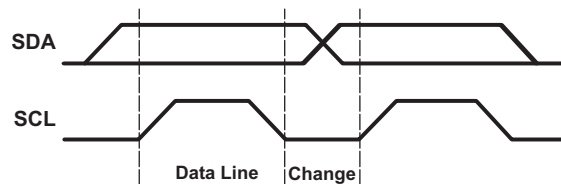

Figure 2. Bit Transfer

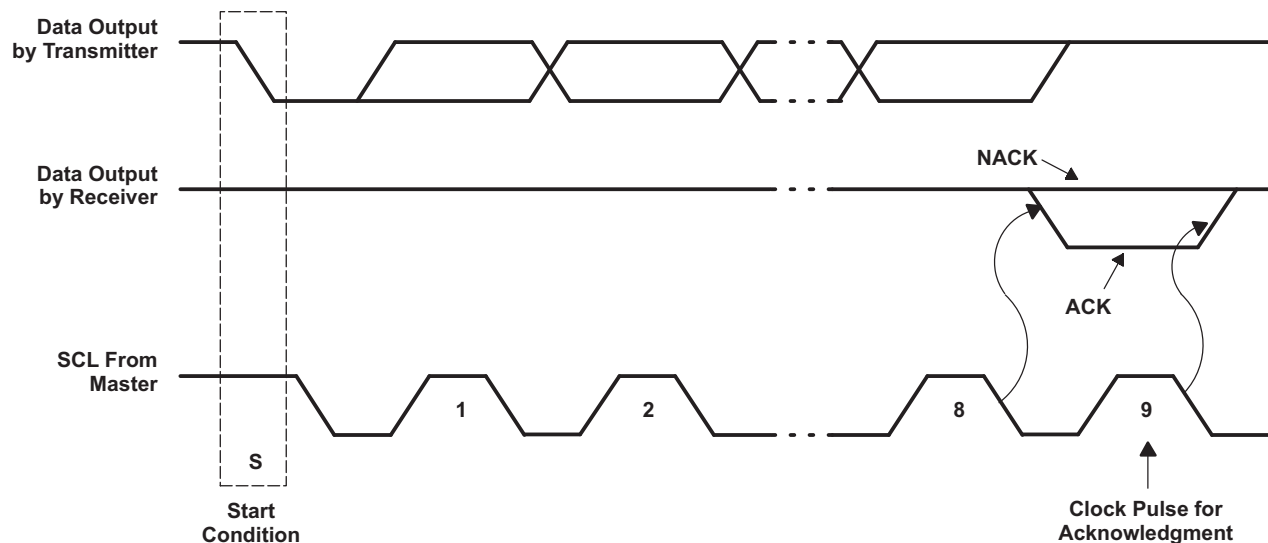

Figure 3. Acknowledgment on the I<sup>2</sup>C Bus

# TCA6408

## LOW-VOLTAGE 8-BIT I<sup>2</sup>C AND SMBus I/O EXPANDER

### WITH INTERRUPT OUTPUT, RESET, AND CONFIGURATION REGISTERS

SCPS151C—FEBRUARY 2007—REVISED JUNE 2007

#### Interface Definition

BYTE	BIT							
	7 (MSB)	6	5	4	3	2	1	0 (LSB)
I <sup>2</sup> C slave address	L	H	L	L	L	L	ADDR	R/W
I/O data bus	P7	P6	P5	P4	P3	P2	P1	P0

#### Device Address

The address of the TCA6408 is shown in Figure 4.

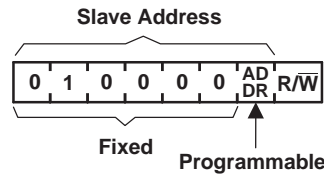

Figure 4. TCA6408 Address

#### Address Reference

ADDR	I <sup>2</sup> C BUS SLAVE ADDRESS
L	32 (decimal), 20 (hexadecimal)
H	33 (decimal), 21 (hexadecimal)

The last bit of the slave address defines the operation (read or write) to be performed. A high (1) selects a read operation, while a low (0) selects a write operation.

#### Control Register and Command Byte

Following the successful acknowledgement of the address byte, the bus master sends a command byte, which is stored in the control register in the TCA6408. Two bits of this data byte state the operation (read or write) and the internal registers (input, output, polarity inversion or configuration) that will be affected. This register can be written or read through the I<sup>2</sup>C bus. The command byte is sent only during a write transmission.

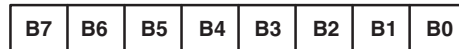

Figure 5. Control Register Bits

#### Command Byte

CONTROL REGISTER BITS								COMMAND BYTE (HEX)	REGISTER	PROTOCOL	POWER-UP DEFAULT
B7	B6	B5	B4	B3	B2	B1	B0				
0	0	0	0	0	0	0	0	00	Input Port	Read byte	xxxx xxxx <sup>(1)</sup>
0	0	0	0	0	0	0	1	01	Output Port	Read/write byte	1111 1111
0	0	0	0	0	0	1	0	02	Polarity Inversion	Read/write byte	0000 0000
0	0	0	0	0	0	1	1	03	Configuration	Read/write byte	1111 1111

(1) Undefined



### Register Descriptions

The input port register (register 0) reflects the incoming logic levels of the pins, regardless of whether the pin is defined as an input or an output by the configuration register. They act only on read operation. Writes to this register have no effect. The default value (X) is determined by the externally applied logic level. Before a read operation, a write transmission is sent with the command byte to indicate to the I<sup>2</sup>C device that the input port register will be accessed next.

#### Register 0 (Input Port Register)

BIT	I-7	I-6	I-5	I-4	I-3	I-2	I-1	I-0
DEFAULT	X	X	X	X	X	X	X	X

The output port register (register 1) shows the outgoing logic levels of the pins defined as outputs by the Configuration register. Bit values in this register have no effect on pins defined as inputs. In turn, reads from this register reflect the value that is in the flip-flop controlling the output selection, not the actual pin value.

#### Register 1 (Output Port Register)

BIT	O-7	O-6	O-5	O-4	O-3	O-2	O-1	O-0
DEFAULT	1	1	1	1	1	1	1	1

The polarity inversion register (register 2) allows polarity inversion of pins defined as inputs by the configuration register. If a bit in this register is set (written with 1), the corresponding port pin's polarity is inverted. If a bit in this register is cleared (written with a 0), the corresponding port pin's original polarity is retained.

#### Register 2 (Polarity Inversion Register)

BIT	N-7	N-6	N-5	N-4	N-3	N-2	N-1	N-0
DEFAULT	0	0	0	0	0	0	0	0

The configuration register (register 3) configures the direction of the I/O pins. If a bit in this register is set to 1, the corresponding port pin is enabled as an input with a high-impedance output driver. If a bit in this register is cleared to 0, the corresponding port pin is enabled as an output.

#### Register 3 (Configuration Register)

BIT	C-7	C-6	C-5	C-4	C-3	C-2	C-1	C-0
DEFAULT	1	1	1	1	1	1	1	1

### Power-On Reset

When power (from 0 V) is applied to  $V_{CCP}$ , an internal power-on reset holds the TCA6408 in a reset condition until  $V_{CCP}$  has reached  $V_{POR}$ . At that time, the reset condition is released, and the TCA6408 registers and I<sup>2</sup>C/SMBus state machine initialize to their default states. After that,  $V_{CCP}$  must be lowered to below 0.2 V and back up to the operating voltage for a power-reset cycle.

### Reset Input ( $\overline{RESET}$ )

The  $\overline{RESET}$  input can be asserted to initialize the system while keeping  $V_{CCP}$  at its operating level. A reset can be accomplished by holding the  $\overline{RESET}$  pin low for a minimum of  $t_w$ . The TCA6408 registers and I<sup>2</sup>C/SMBus state machine are changed to their default state once  $\overline{RESET}$  is low (0). When  $\overline{RESET}$  is high (1), the I/O levels at the P port can be changed externally or through the master. This input requires a pullup resistor to  $V_{CCP}$ , if no active connection is used.

### Interrupt Output ( $\overline{\text{INT}}$ )

An interrupt is generated by any rising or falling edge of the port inputs in the input mode. After time  $t_{IV}$ , the signal  $\overline{\text{INT}}$  is valid. Resetting the interrupt circuit is achieved when data on the port is changed to the original setting, data is read from the port that generated the interrupt or in a stop event. Resetting occurs in the read mode at the acknowledge (ACK) or not acknowledge (NACK) bit after the rising edge of the SCL signal. In a stop event,  $\overline{\text{INT}}$  is cleared after the rising edge of SDA. Interrupts that occur during the ACK or NACK clock pulse can be lost (or be very short) due to the resetting of the interrupt during this pulse. Each change of the I/Os after resetting is detected and is transmitted as  $\overline{\text{INT}}$ .

Reading from or writing to another device does not affect the interrupt circuit, and a pin configured as an output cannot cause an interrupt. Changing an I/O from an output to an input may cause a false interrupt to occur, if the state of the pin does not match the contents of the input port register.

The  $\overline{\text{INT}}$  output has an open-drain structure and requires a pullup resistor to  $V_{CCP}$  or  $V_{CCI}$  depending on the application. If the  $\overline{\text{INT}}$  signal is connected back to the processor that provides the SCL signal to the TCA6408, then the  $\overline{\text{INT}}$  pin has to be connected to  $V_{CCI}$ . If not, the INT pin can be connected to  $V_{CCP}$ .

### Bus Transactions

Data is exchanged between the master and TCA6408 through write and read commands.

#### Writes

Data is transmitted to the TCA6408 by sending the device address and setting the least-significant bit to a logic 0 (see Figure 4 for device address). The command byte is sent after the address and determines which register receives the data that follows the command byte. There is no limitation on the number of data bytes sent in one write transmission.

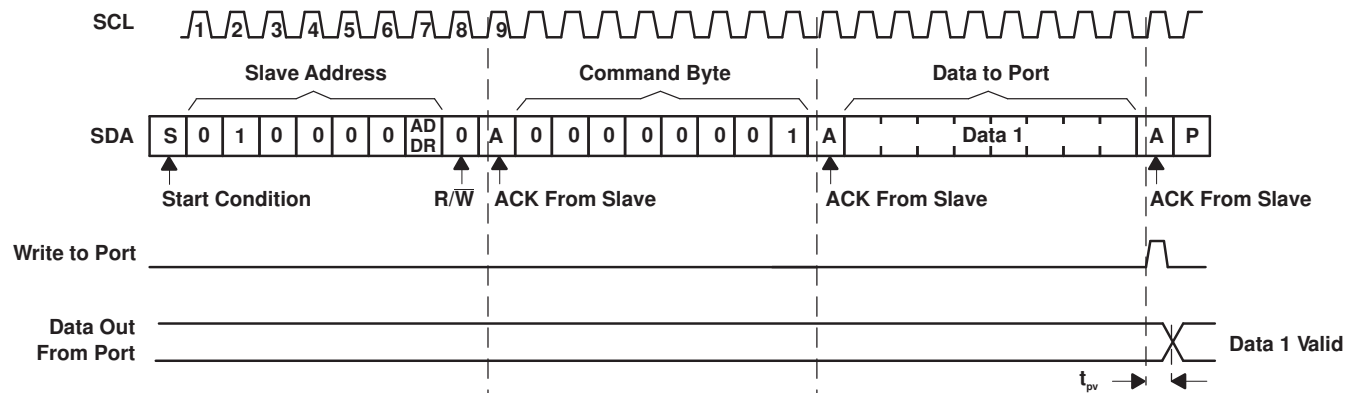

**Figure 6. Write to Output Port Register**

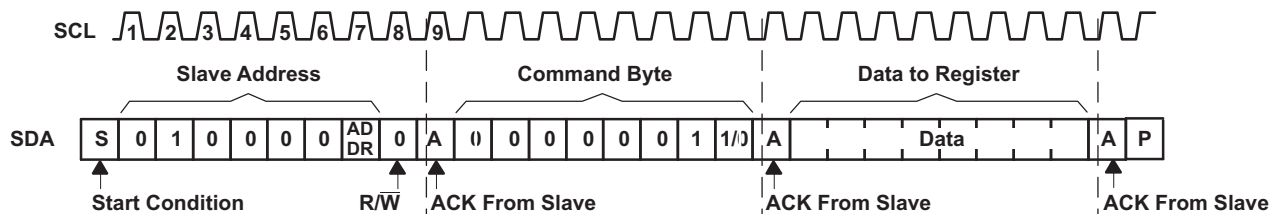

**Figure 7. Write to Configuration or Polarity Inversion Registers**

## Reads

The bus master first must send the TCA6408 address with the least-significant bit set to a logic 0 (see Figure 4 for device address). The command byte is sent after the address and determines which register is accessed.

After a restart, the device address is sent again but, this time, the least-significant bit is set to a logic 1. Data from the register defined by the command byte then is sent by the TCA6408 (see Figure 8 and Figure 9).

Data is clocked into the register on the rising edge of the ACK clock pulse.

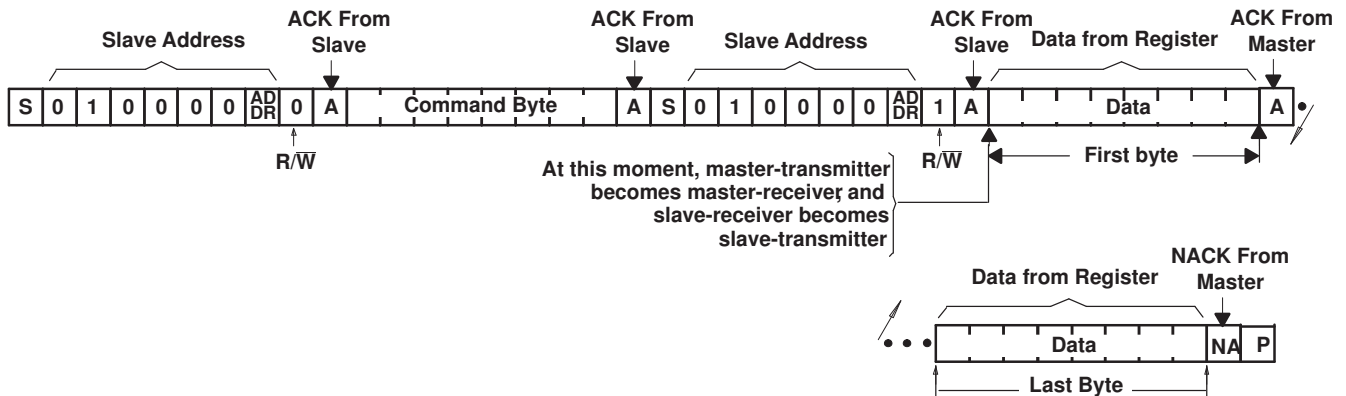
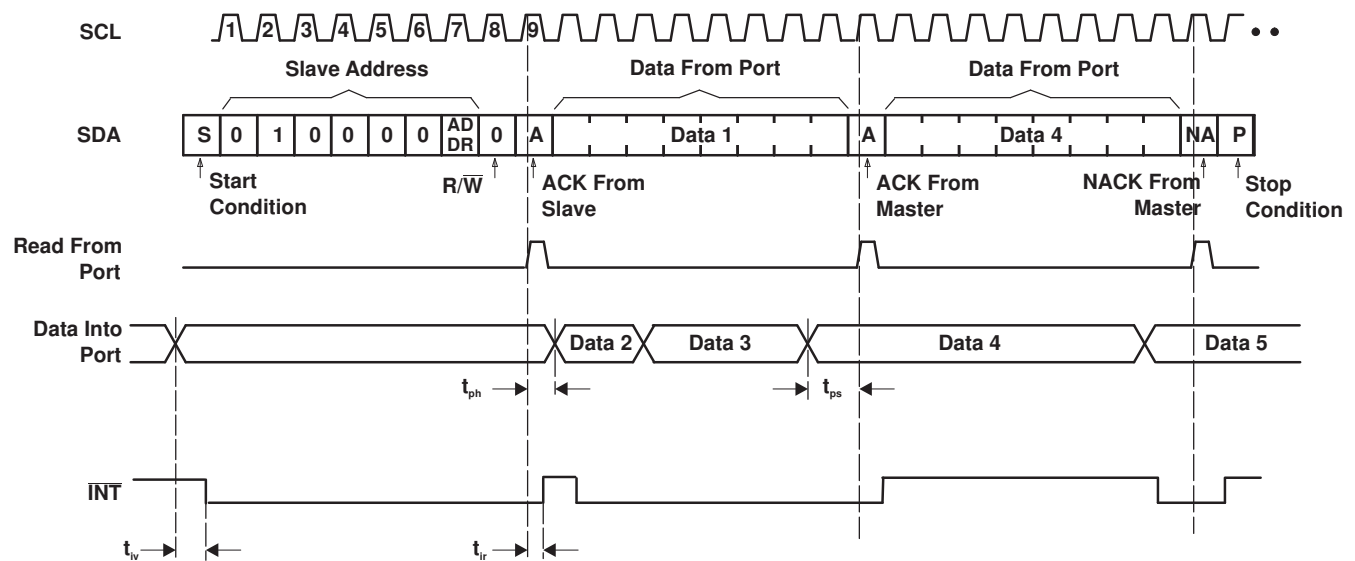

Figure 8. Read From Register



- Transfer of data can be stopped at any time by a stop condition. When this occurs, data present at the latest acknowledge phase is valid (output mode). It is assumed that the command byte previously has been set to 00 (read input port register).
- This figure eliminates the command byte transfer, a restart, and slave address call between the initial slave address call and actual data transfer from P port (see Figure 8).

Figure 9. Read Input Port Register

# TCA6408

## LOW-VOLTAGE 8-BIT I<sup>2</sup>C AND SMBus I/O EXPANDER WITH INTERRUPT OUTPUT, RESET, AND CONFIGURATION REGISTERS

SCPS151C—FEBRUARY 2007—REVISED JUNE 2007

### Absolute Maximum Ratings<sup>(1)</sup>

over operating free-air temperature range (unless otherwise noted)

				MIN	MAX	UNIT	
V <sub>CCI</sub>	Supply voltage range			-0.5	6.5	V	
V <sub>CCP</sub>	Supply voltage range			-0.5	6.5	V	
V <sub>I</sub>	Input voltage range <sup>(2)</sup>			-0.5	6.5	V	
V <sub>O</sub>	Output voltage range <sup>(2)</sup>			-0.5	6.5	V	
I <sub>IK</sub>	Input clamp current	ADDR, $\overline{\text{RESET}}$ , SCL	V <sub>I</sub> < 0		±20	mA	
I <sub>OK</sub>	Output clamp current	$\overline{\text{INT}}$	V <sub>O</sub> < 0		±20	mA	
I <sub>IOK</sub>	Input/output clamp current	P Port	V <sub>O</sub> < 0 or V <sub>O</sub> > V <sub>CCP</sub>		±20	mA	
		SDA	V <sub>O</sub> < 0 or V <sub>O</sub> > V <sub>CCI</sub>		±20	mA	
I <sub>OL</sub>	Continuous output low current	P Port	V <sub>O</sub> = 0 to V <sub>CCP</sub>		50	mA	
	Continuous output low current	SDA, $\overline{\text{INT}}$	V <sub>O</sub> = 0 to V <sub>CCI</sub>		25	mA	
I <sub>OH</sub>	Continuous output high current	P Port	V <sub>O</sub> = 0 to V <sub>CCP</sub>		50	mA	
I <sub>CC</sub>	Continuous current through GND				200	mA	
	Continuous current through V <sub>CCP</sub>				160	mA	
	Continuous current through V <sub>CCI</sub>				10	mA	
θ <sub>JA</sub>	Package thermal impedance <sup>(3)</sup>		PW package		108	°C/W	
			RGT package		53		
			ZXY package		193		
T <sub>stg</sub>	Storage temperature range				-65	150	°C

(1) Stresses beyond those listed under “absolute maximum ratings” may cause permanent damage to the device. These are stress ratings only, and functional operation of the device at these or any other conditions beyond those indicated under “recommended operating conditions” is not implied. Exposure to absolute-maximum-rated conditions for extended periods may affect device reliability.

(2) The input negative-voltage and output voltage ratings may be exceeded if the input and output current ratings are observed.

(3) The package thermal impedance is calculated in accordance with JESD 51-7.

### Recommended Operating Conditions

				MIN	MAX	UNIT	
V <sub>CCI</sub>	Supply voltage			1.65	5.5	V	
V <sub>CCP</sub>	Supply voltage			1.65	5.5		
V <sub>IH</sub>	High-level input voltage	SCL, SDA	0.7 × V <sub>CCI</sub>	5.5	V		
		ADDR, P7–P0, $\overline{\text{RESET}}$	0.7 × V <sub>CCP</sub>	5.5			
V <sub>IL</sub>	Low-level input voltage	SCL, SDA	-0.5	0.3 × V <sub>CCI</sub>	V		
		ADDR, P7–P0, $\overline{\text{RESET}}$	-0.5	0.3 × V <sub>CCP</sub>			
I <sub>OH</sub>	High-level output current	P7–P0		10	mA		
I <sub>OL</sub>	Low-level output current	P7–P0		25	mA		
T <sub>A</sub>	Operating free-air temperature				-40	85	°C

### Electrical Characteristics

 over recommended operating free-air temperature range,  $V_{CCI} = 1.65\text{ V to }5.5\text{ V}$  (unless otherwise noted)

PARAMETER		TEST CONDITIONS	$V_{CCP}$	MIN	TYP <sup>(1)</sup>	MAX	UNIT
$V_{IK}$	Input diode clamp voltage	$I_I = -18\text{ mA}$	1.65 V to 5.5 V	-1.2			V
$V_{POR}$	Power-on reset voltage <sup>(2)</sup>	$V_I = V_{CCP}$ or GND, $I_O = 0$	1.65 V to 5.5 V		1	1.4	V
$V_{OH}$	P port high-level output voltage	$I_{OH} = -8\text{ mA}$	1.65 V	1.2			V
			2.3 V	1.8			
			3 V	2.6			
			4.5 V	4.1			
		$I_{OH} = -10\text{ mA}$	1.65 V	1.1			
			2.3 V	1.7			
			3 V	2.5			
			4.5 V	4.0			
$V_{OL}$	P port low-level output voltage	$I_{OL} = 8\text{ mA}$	1.65 V			0.45	V
			2.3 V			0.25	
			3 V			0.25	
			4.5 V			0.2	
		$I_{OL} = 10\text{ mA}$	1.65 V			0.6	
			2.3 V			0.3	
			3 V			0.25	
			4.5 V			0.2	
$I_{OL}$	SDA	$V_{OL} = 0.4\text{ V}$	1.65 V to 5.5 V	3			mA
	INT	$V_{OL} = 0.4\text{ V}$	1.65 V to 5.5 V	3	15		
$I_I$	SCL, SDA	$V_I = V_{CCI}$ or GND	1.65 V to 5.5 V			$\pm 0.1$	$\mu\text{A}$
	ADDR, RESET	$V_I = V_{CCP}$ or GND				$\pm 0.1$	
$I_{IH}$	P port	$V_I = V_{CCP}$	1.65 V to 5.5 V			1	$\mu\text{A}$
$I_{IL}$	P port	$V_I = \text{GND}$				1	$\mu\text{A}$
$I_{CC}$ ( $I_{CCI} + I_{CCP}$ )	Operating mode	SDA, P Port, ADDR, RESET	$V_I$ on SDA = $V_{CCI}$ or GND, $V_I$ on P port, ADDR and RESET = $V_{CCP}$ or GND, $I_O = 0$ , I/O = inputs, $f_{SCL} = 400\text{ kHz}$	3.6 V to 5.5 V	10	20	$\mu\text{A}$
			2.3 V to 3.6 V	6.5	15		
			1.65 V to 2.3 V	4	9		
	Operating mode	SDA, P Port, ADDR, RESET	$V_I$ on SDA = $V_{CCI}$ or GND, $V_I$ on P port, ADDR and RESET = $V_{CCP}$ or GND, $I_O = 0$ , I/O = inputs, $f_{SCL} = 100\text{ kHz}$	3.6 V to 5.5 V	2.5	5	
				2.3 V to 3.6 V	1.6	3.8	
				1.65 V to 2.3 V	1	2.3	
	Standby mode	SCL, SDA, P Port, ADDR, RESET	$V_I$ on SCL and SDA = $V_{CCI}$ or GND, $V_I$ on P Port, ADDR and RESET = $V_{CCP}$ or GND, $I_O = 0$ , I/O = inputs, $f_{SCL} = 0$	3.6 V to 5.5 V	0.2	1	
				2.3 V to 3.6 V	0.1	0.6	
				1.65 V to 2.3 V	0.1	0.4	
$\Delta I_{CCI}$	Additional current in Standby mode	SCL, SDA	One input at $V_{CCI} - 0.6\text{ V}$ , Other inputs at $V_{CCI}$ or GND	1.65 V to 5.5 V		25	$\mu\text{A}$
P Port, ADDR, RESET		One input at $V_{CCP} - 0.6\text{ V}$ , Other inputs at $V_{CCP}$ or GND	1.65 V to 5.5 V		60	$\mu\text{A}$	
$C_i$	SCL	$V_I = V_{CCI}$ or GND	1.65 V to 5.5 V		6	7	pF
$C_{io}$	SDA	$V_{IO} = V_{CCI}$ or GND	1.65 V to 5.5 V		7	8	pF
	P Port	$V_{IO} = V_{CCP}$ or GND			7.5	8.5	

 (1) All typical values are at nominal supply voltage (1.8-V, 2.5-V, 3.3-V, or 5-V  $V_{CC}$ ) and  $T_A = 25^\circ\text{C}$ .

 (2) When power (from 0 V) is applied to  $V_{CCP}$ , an internal power-on reset holds the TCA6408 in a reset condition until  $V_{CCP}$  has reached  $V_{POR}$ . At that time, the reset condition is released, and the TCA6408 registers and I<sup>2</sup>C/SMBus state machine initialize to their default states. After that,  $V_{CCP}$  must be lowered to below 0.2 V and back up to the operating voltage for a power-reset cycle.

# TCA6408

## LOW-VOLTAGE 8-BIT I<sup>2</sup>C AND SMBus I/O EXPANDER WITH INTERRUPT OUTPUT, RESET, AND CONFIGURATION REGISTERS

SCPS151C—FEBRUARY 2007—REVISED JUNE 2007

### I<sup>2</sup>C Interface Timing Requirements

over recommended operating free-air temperature range (unless otherwise noted) (see [Figure 10](#))

		STANDARD MODE I <sup>2</sup> C BUS		FAST MODE I <sup>2</sup> C BUS		UNIT
		MIN	MAX	MIN	MAX	
f <sub>scl</sub>	I <sup>2</sup> C clock frequency	0	100	0	400	kHz
t <sub>sch</sub>	I <sup>2</sup> C clock high time	4		0.6		μs
t <sub>scl</sub>	I <sup>2</sup> C clock low time	4.7		1.3		μs
t <sub>sp</sub>	I <sup>2</sup> C spike time	0	50	0	50	ns
t <sub>sds</sub>	I <sup>2</sup> C serial data setup time	250		100		ns
t <sub>sdh</sub>	I <sup>2</sup> C serial data hold time	0		0		ns
t <sub>icr</sub>	I <sup>2</sup> C input rise time		1000	20 + 0.1C <sub>b</sub> <sup>(1)</sup>	300	ns
t <sub>icf</sub>	I <sup>2</sup> C input fall time		300	20 + 0.1C <sub>b</sub> <sup>(1)</sup>	300	ns
t <sub>ocf</sub>	I <sup>2</sup> C output fall time; 10 pF to 400 pF bus		300	20 + 0.1C <sub>b</sub> <sup>(1)</sup>	300	μs
t <sub>buf</sub>	I <sup>2</sup> C bus free time between Stop and Start	4.7		1.3		μs
t <sub>sts</sub>	I <sup>2</sup> C Start or repeater Start condition setup time	4.7		0.6		μs
t <sub>sth</sub>	I <sup>2</sup> C Start or repeater Start condition hold time	4		0.6		μs
t <sub>sps</sub>	I <sup>2</sup> C Stop condition setup time	4		0.6		μs
t <sub>vd(data)</sub>	Valid data time; SCL low to SDA output valid		1		1	μs
t <sub>vd(ack)</sub>	Valid data time of ACK condition; ACK signal from SCL low to SDA (out) low		1		1	μs

(1) C<sub>b</sub> = total capacitance of one bus line in pF

### Reset Timing Requirements

over recommended operating free-air temperature range (unless otherwise noted) (see [Figure 13](#))

		STANDARD MODE I <sup>2</sup> C BUS		FAST MODE I <sup>2</sup> C BUS		UNIT
		MIN	MAX	MIN	MAX	
t <sub>w</sub>	Reset pulse duration	4		4		ns
t <sub>REC</sub>	Reset recovery time	0		0		ns
t <sub>RESET</sub>	Time to reset <sup>(1)</sup>	600		600		ns

(1) Minimum time for SDA to become high or minimum time to wait before doing a START

### Switching Characteristics

over recommended operating free-air temperature range, C<sub>L</sub> ≤ 100 pF (unless otherwise noted) (see [Figure 10](#))

PARAMETER	FROM	TO	STANDARD MODE I <sup>2</sup> C BUS		FAST MODE I <sup>2</sup> C BUS		UNIT
			MIN	MAX	MIN	MAX	
t <sub>iv</sub>	Interrupt valid time	P Port		4		4	μs
t <sub>ir</sub>	Interrupt reset delay time	SCL		4		4	μs
t <sub>pv</sub>	Output data valid	SCL		400		400	ns
t <sub>ps</sub>	Input data setup time	P Port	0		0		ns
t <sub>ph</sub>	Input data hold time	P Port	300		300		ns

TYPICAL CHARACTERISTICS

T<sub>A</sub> = 25°C (unless otherwise noted)

SUPPLY CURRENT  
vs  
TEMPERATURE

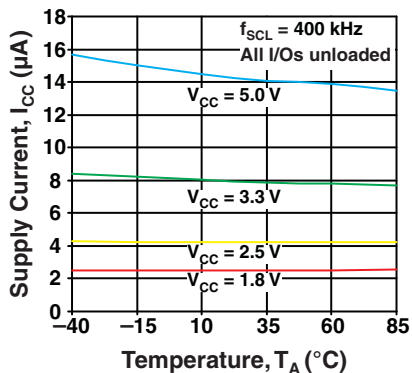

STANDBY SUPPLY CURRENT  
vs  
TEMPERATURE

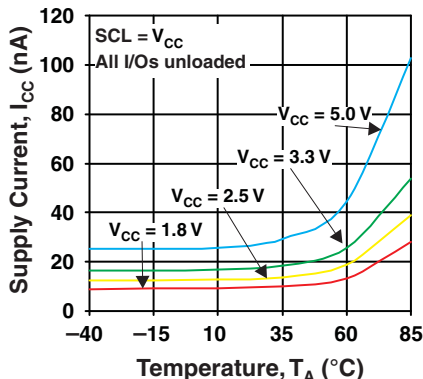

SUPPLY CURRENT  
vs  
SUPPLY VOLTAGE

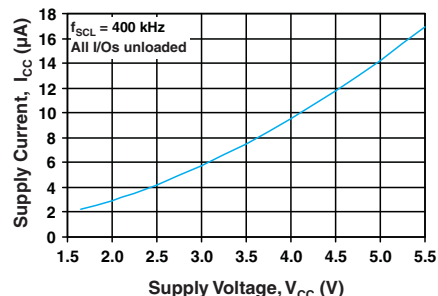

I/O SINK CURRENT  
vs  
OUTPUT LOW VOLTAGE

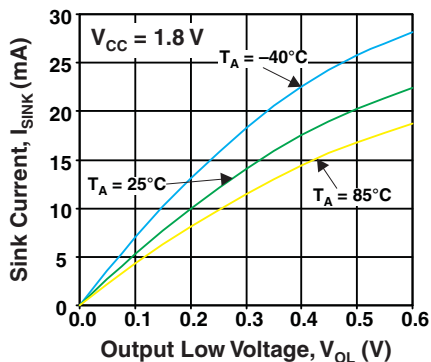

I/O SINK CURRENT  
vs  
OUTPUT LOW VOLTAGE

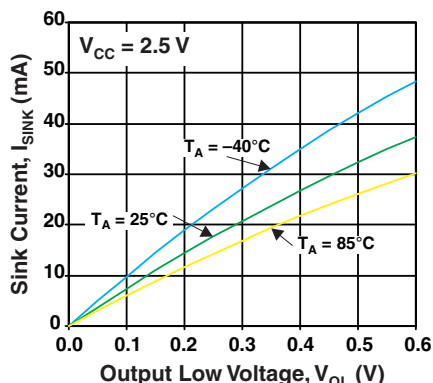

I/O SINK CURRENT  
vs  
OUTPUT LOW VOLTAGE

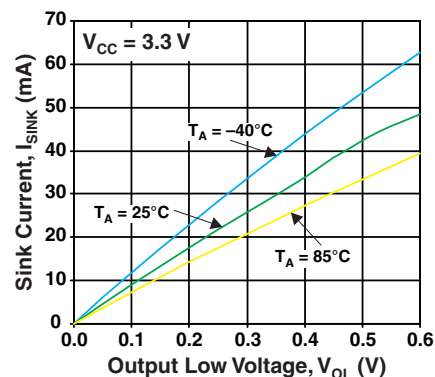

I/O SINK CURRENT  
vs  
OUTPUT LOW VOLTAGE

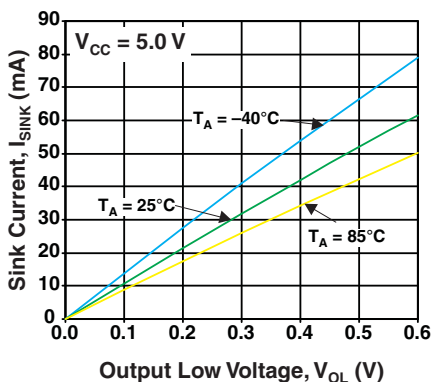

I/O LOW VOLTAGE  
vs  
TEMPERATURE

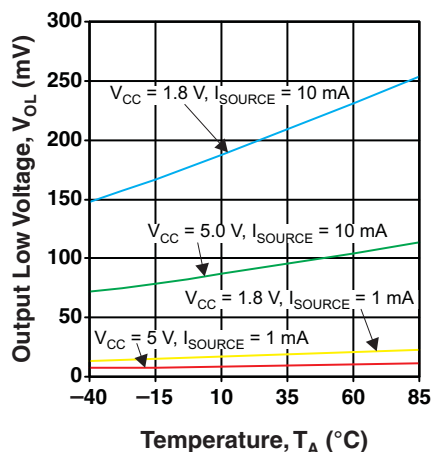

I/O SOURCE CURRENT  
vs  
OUTPUT HIGH VOLTAGE

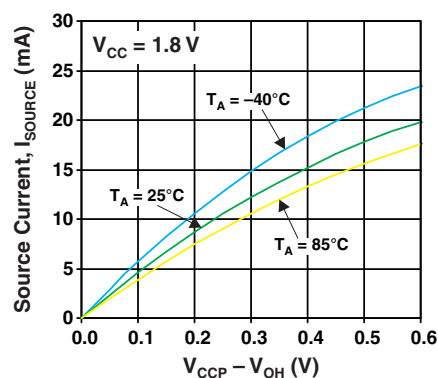

**TYPICAL CHARACTERISTICS (continued)**

T<sub>A</sub> = 25°C (unless otherwise noted)

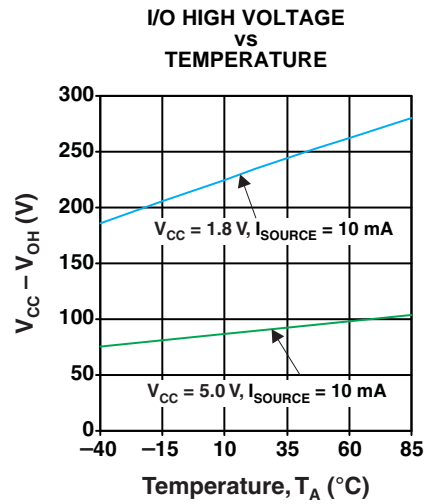
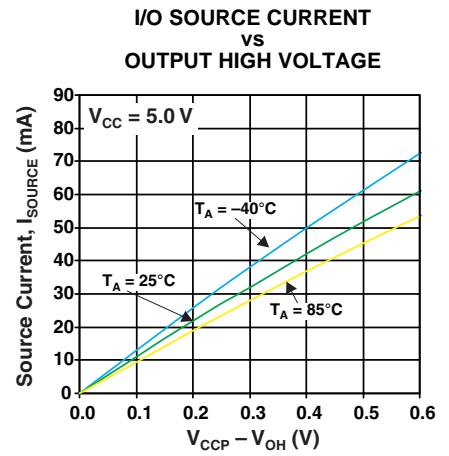
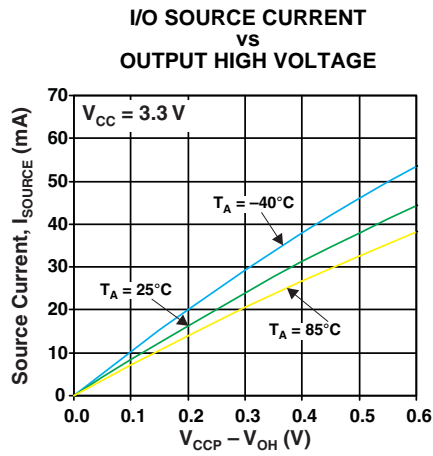
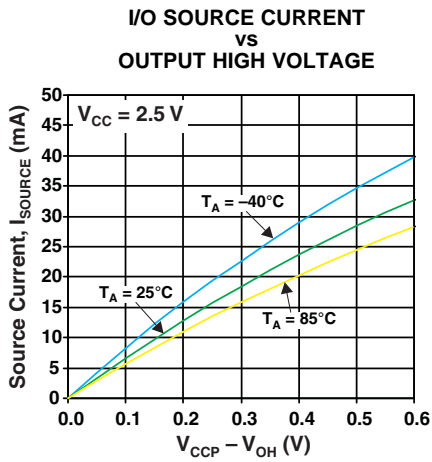



PARAMETER MEASUREMENT INFORMATION

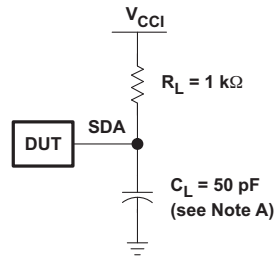

SDA LOAD CONFIGURATION

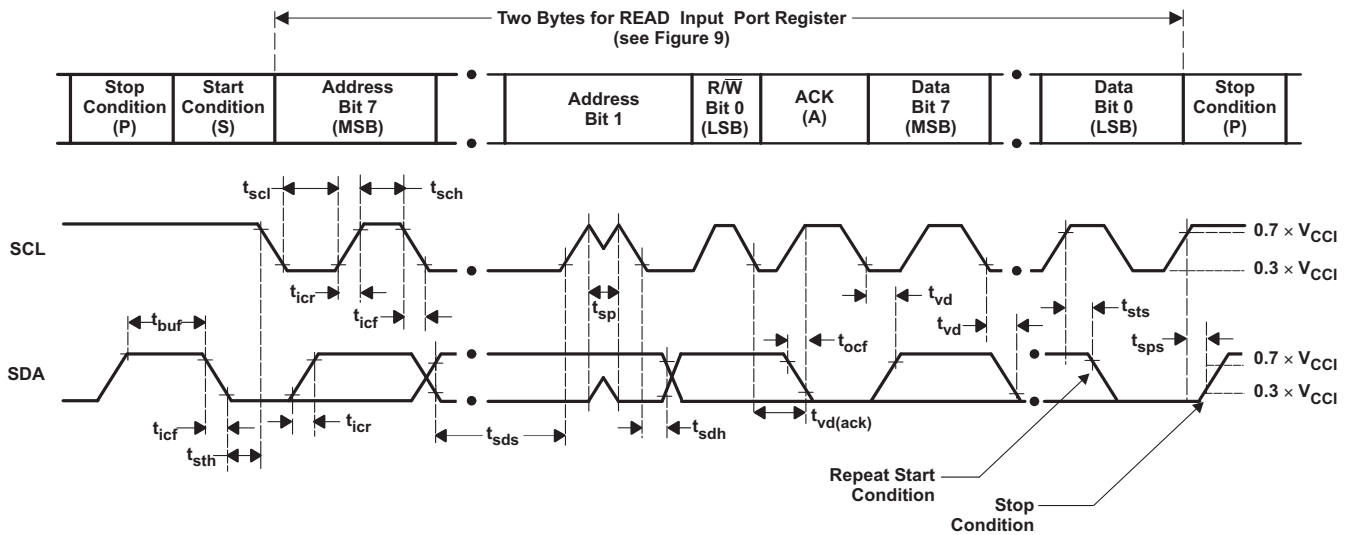

VOLTAGE WAVEFORMS

BYTE	DESCRIPTION
1	I <sup>2</sup> C address
2	Input register port data

- A.  $C_L$  includes probe and jig capacitance.  $t_{ocf}$  is measured with  $C_L$  of 10 pF or 400 pF.
- B. All inputs are supplied by generators having the following characteristics:  $PRR \leq 10$  MHz,  $Z_O = 50 \Omega$ ,  $t_r/t_f \leq 30$  ns.
- C. All parameters and waveforms are not applicable to all devices.

Figure 10. I<sup>2</sup>C Interface Load Circuit and Voltage Waveforms

PARAMETER MEASUREMENT INFORMATION (continued)

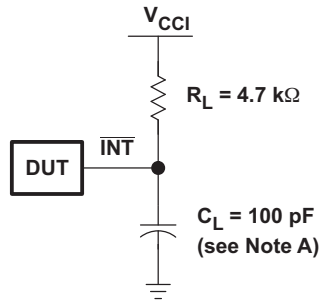

INTERRUPT LOAD CONFIGURATION

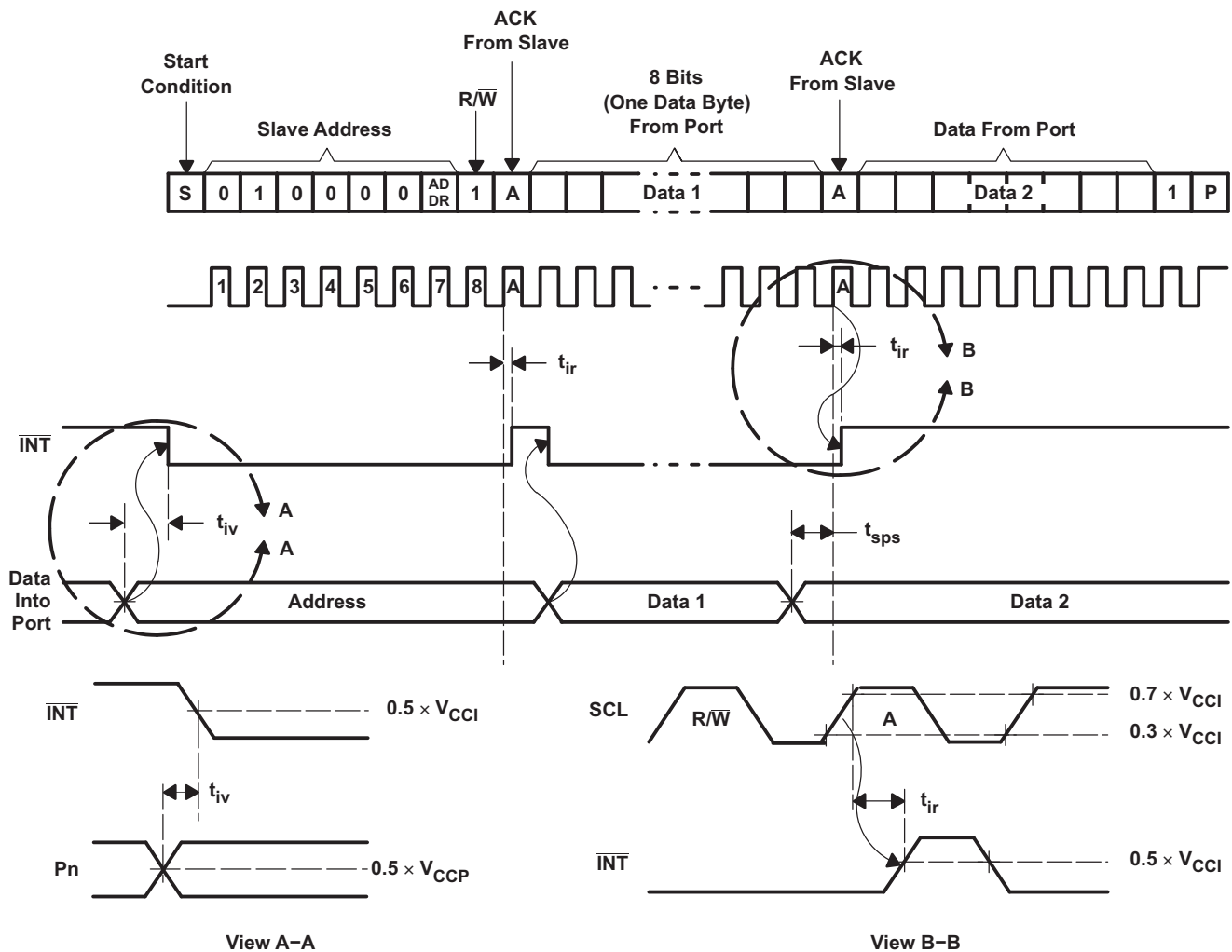

- A.  $C_L$  includes probe and jig capacitance.
- B. All inputs are supplied by generators having the following characteristics:  $PRR \leq 10$  MHz,  $Z_O = 50 \Omega$ ,  $t_r/t_f \leq 30$  ns.
- C. All parameters and waveforms are not applicable to all devices.

Figure 11. Interrupt Load Circuit and Voltage Waveforms

PARAMETER MEASUREMENT INFORMATION (continued)

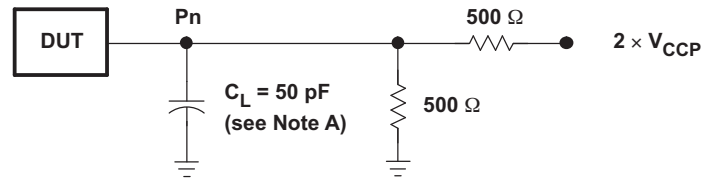

P PORT LOAD CONFIGURATION

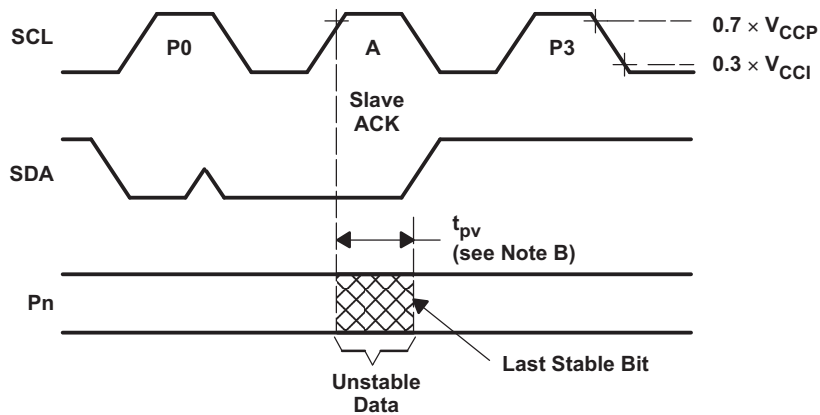

WRITE MODE ( $R/\bar{W} = 0$ )

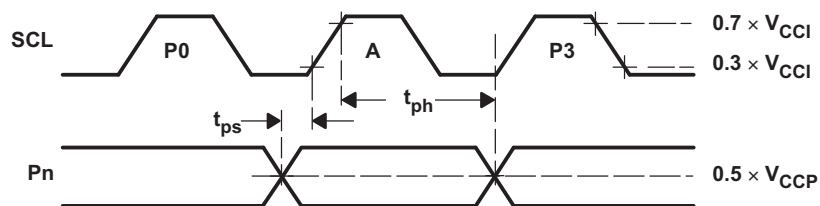

READ MODE ( $R/\bar{W} = 1$ )

- A.  $C_L$  includes probe and jig capacitance.
- B.  $t_{pv}$  is measured from  $0.7 \times V_{CC}$  on SCL to 50% I/O ( $P_n$ ) output.
- C. All inputs are supplied by generators having the following characteristics:  $PRR \leq 10$  MHz,  $Z_O = 50 \Omega$ ,  $t_r/t_f \leq 30$  ns.
- D. The outputs are measured one at a time, with one transition per measurement.
- E. All parameters and waveforms are not applicable to all devices.

Figure 12. P Port Load Circuit and Timing Waveforms

PARAMETER MEASUREMENT INFORMATION (continued)

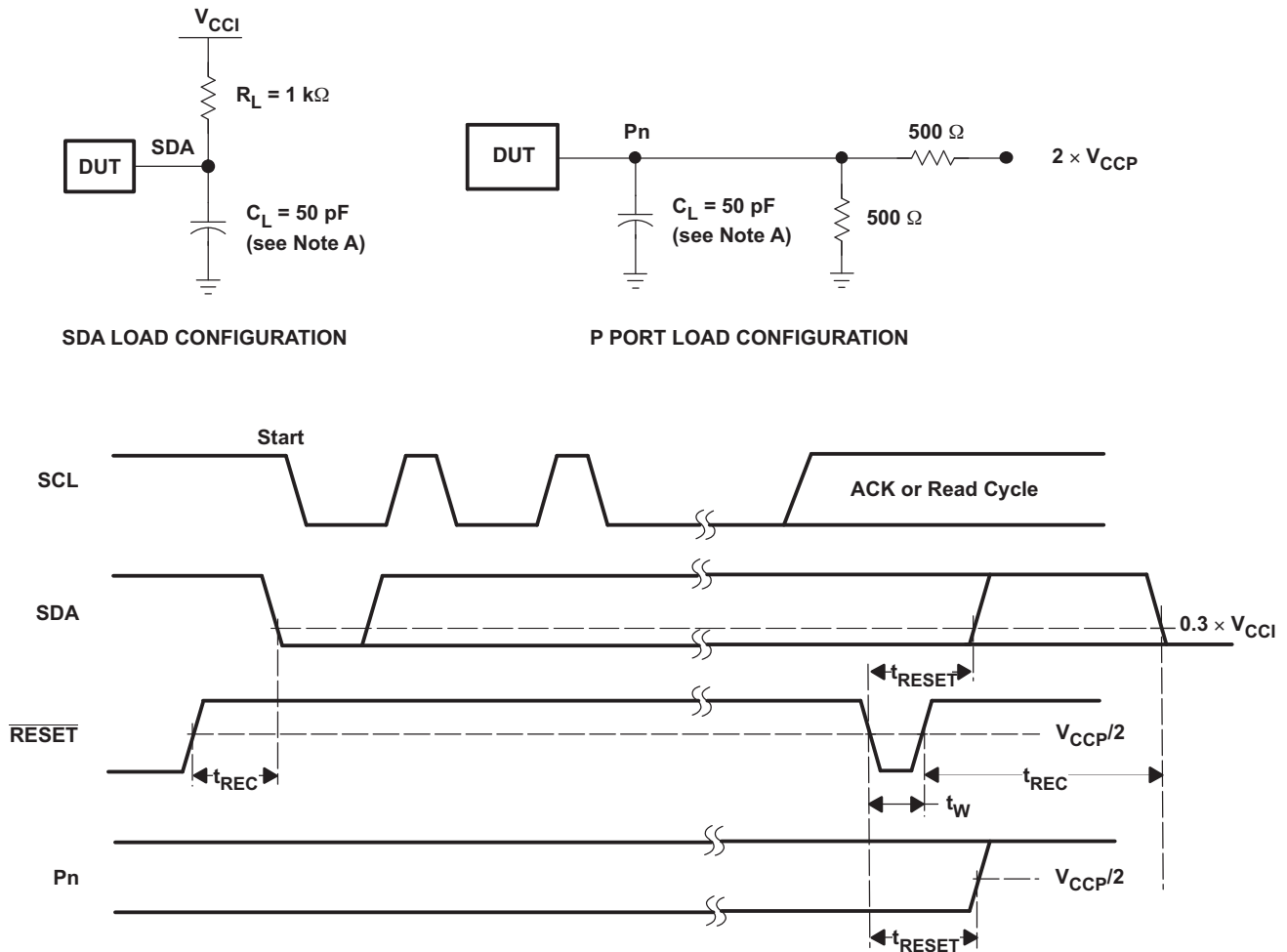

- A.  $C_L$  includes probe and jig capacitance.
- B. All inputs are supplied by generators having the following characteristics:  $PRR \leq 10$  MHz,  $Z_O = 50 \Omega$ ,  $t_r/t_f \leq 30$  ns.
- C. The outputs are measured one at a time, with one transition per measurement.
- D. I/Os are configured as inputs.
- E. All parameters and waveforms are not applicable to all devices.

Figure 13. Reset Load Circuits and Voltage Waveforms

### APPLICATION INFORMATION

Figure 14 shows an application in which the TCA6408 can be used.

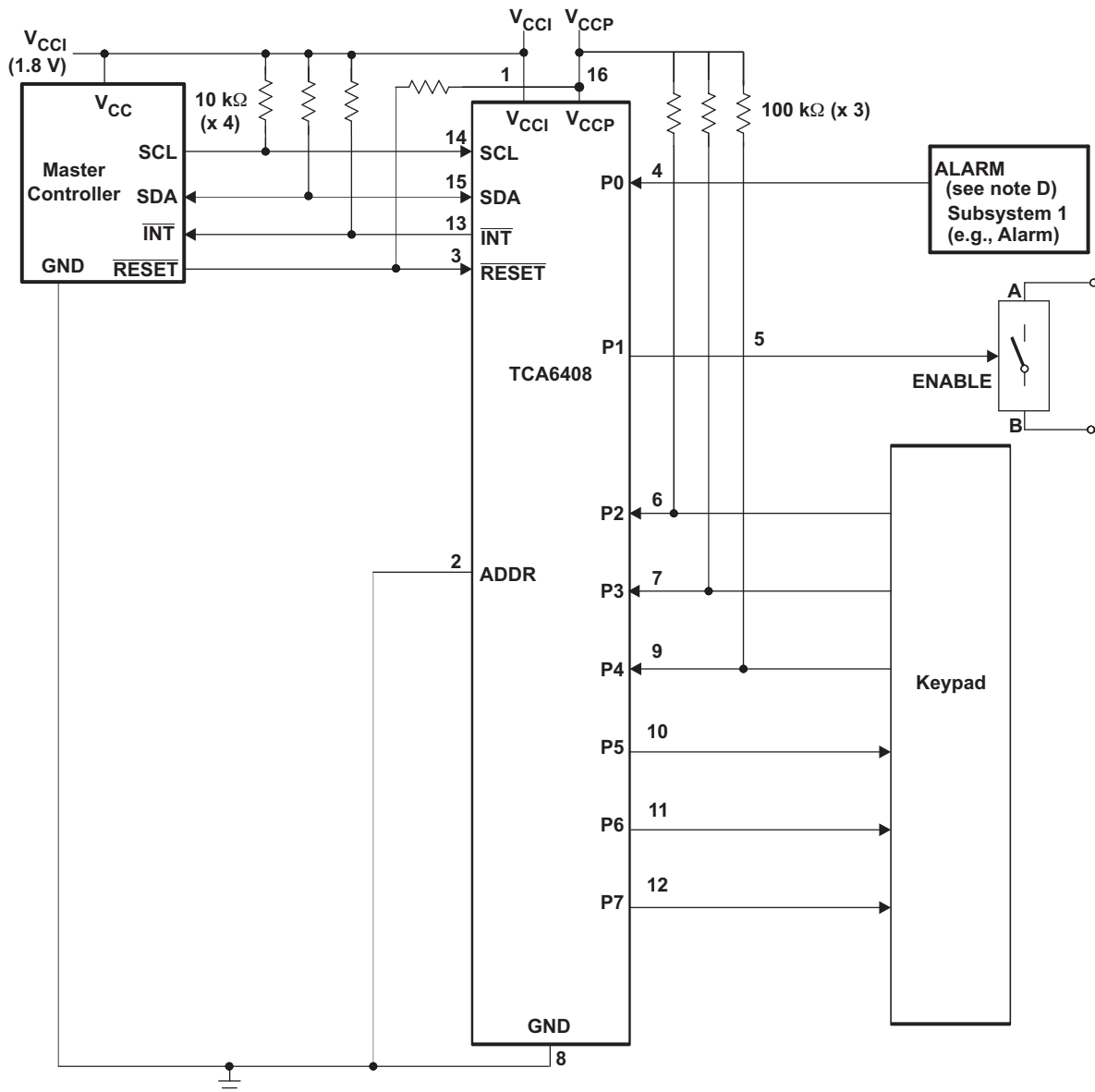

- A. Device address configured as 0100000 for this example.
- B. P0 and P2–P4 are configured as inputs.
- C. P1 and P5–P7 are configured as outputs.
- D. Resistors are required for inputs (on P port) that may float. If a driver to an input will never let the input float, a resistor is not needed. Outputs (in the P port) do not need pullup resistors.

**Figure 14. Typical Application**

### APPLICATION INFORMATION (continued)

#### Minimizing I<sub>CC</sub> When the I/O is Used to Control LEDs

When the I/Os are used to control LEDs, normally they are connected to V<sub>CC</sub> through a resistor as shown in Figure 14. The LED acts as a diode so when the LED is off the I/O V<sub>IN</sub> is about 1.2 V less than V<sub>CC</sub>. The ΔI<sub>CC</sub> parameter in "Electrical Characteristics" shows how I<sub>CC</sub> increases as V<sub>IN</sub> becomes lower than V<sub>CC</sub>. Designs needing to minimize current consumption, such as battery power applications, should consider maintaining the I/O pins greater than or equal to V<sub>CC</sub> when the LED is off.

Figure 15 shows a high-value resistor in parallel with the LED. Figure 16 shows V<sub>CC</sub> less than the LED supply voltage by at least 1.2 V. Both of these methods maintain the I/O V<sub>IN</sub> at or above V<sub>CC</sub> and prevent additional supply current consumption when the LED is off.

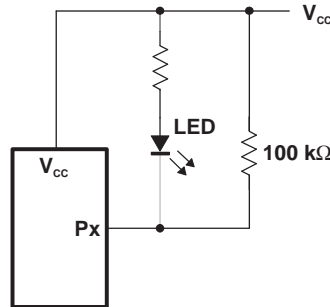

Figure 15. High-Value Resistor in Parallel With the LED

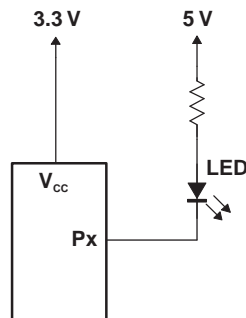

Figure 16. Device Supplied by a Low Voltage

**PACKAGING INFORMATION**

Orderable Device	Status <sup>(1)</sup>	Package Type	Package Drawing	Pins	Package Qty	Eco Plan <sup>(2)</sup>	Lead/Ball Finish	MSL Peak Temp <sup>(3)</sup>
TCA6408PW	ACTIVE	TSSOP	PW	16	90	Green (RoHS & no Sb/Br)	CU NIPDAU	Level-1-260C-UNLIM
TCA6408PWG4	ACTIVE	TSSOP	PW	16	90	Green (RoHS & no Sb/Br)	CU NIPDAU	Level-1-260C-UNLIM
TCA6408PWR	ACTIVE	TSSOP	PW	16	2000	Green (RoHS & no Sb/Br)	CU NIPDAU	Level-1-260C-UNLIM
TCA6408PWRG4	ACTIVE	TSSOP	PW	16	2000	Green (RoHS & no Sb/Br)	CU NIPDAU	Level-1-260C-UNLIM
TCA6408RGTR	ACTIVE	QFN	RGT	16	3000	Green (RoHS & no Sb/Br)	CU NIPDAU	Level-2-260C-1 YEAR
TCA6408RGTRG4	ACTIVE	QFN	RGT	16	3000	Green (RoHS & no Sb/Br)	CU NIPDAU	Level-2-260C-1 YEAR
TCA6408ZXYP	ACTIVE	BGA MI CROSTA R JUNI OR	ZXY	20	2500	Green (RoHS & no Sb/Br)	SNAGCU	Level-1-260C-UNLIM

<sup>(1)</sup> The marketing status values are defined as follows:

**ACTIVE:** Product device recommended for new designs.

**LIFEBUY:** TI has announced that the device will be discontinued, and a lifetime-buy period is in effect.

**NRND:** Not recommended for new designs. Device is in production to support existing customers, but TI does not recommend using this part in a new design.

**PREVIEW:** Device has been announced but is not in production. Samples may or may not be available.

**OBsolete:** TI has discontinued the production of the device.

<sup>(2)</sup> Eco Plan - The planned eco-friendly classification: Pb-Free (RoHS), Pb-Free (RoHS Exempt), or Green (RoHS & no Sb/Br) - please check <http://www.ti.com/productcontent> for the latest availability information and additional product content details.

**TBD:** The Pb-Free/Green conversion plan has not been defined.

**Pb-Free (RoHS):** TI's terms "Lead-Free" or "Pb-Free" mean semiconductor products that are compatible with the current RoHS requirements for all 6 substances, including the requirement that lead not exceed 0.1% by weight in homogeneous materials. Where designed to be soldered at high temperatures, TI Pb-Free products are suitable for use in specified lead-free processes.

**Pb-Free (RoHS Exempt):** This component has a RoHS exemption for either 1) lead-based flip-chip solder bumps used between the die and package, or 2) lead-based die adhesive used between the die and leadframe. The component is otherwise considered Pb-Free (RoHS compatible) as defined above.

**Green (RoHS & no Sb/Br):** TI defines "Green" to mean Pb-Free (RoHS compatible), and free of Bromine (Br) and Antimony (Sb) based flame retardants (Br or Sb do not exceed 0.1% by weight in homogeneous material)

<sup>(3)</sup> MSL, Peak Temp. -- The Moisture Sensitivity Level rating according to the JEDEC industry standard classifications, and peak solder temperature.

**Important Information and Disclaimer:** The information provided on this page represents TI's knowledge and belief as of the date that it is provided. TI bases its knowledge and belief on information provided by third parties, and makes no representation or warranty as to the accuracy of such information. Efforts are underway to better integrate information from third parties. TI has taken and continues to take reasonable steps to provide representative and accurate information but may not have conducted destructive testing or chemical analysis on incoming materials and chemicals. TI and TI suppliers consider certain information to be proprietary, and thus CAS numbers and other limited information may not be available for release.

In no event shall TI's liability arising out of such information exceed the total purchase price of the TI part(s) at issue in this document sold by TI to Customer on an annual basis.

**TAPE AND REEL INFORMATION**



**QUADRANT ASSIGNMENTS FOR PIN 1 ORIENTATION IN TAPE**



\*All dimensions are nominal

Device	Package Type	Package Drawing	Pins	SPQ	Reel Diameter (mm)	Reel Width W1 (mm)	A0 (mm)	B0 (mm)	K0 (mm)	P1 (mm)	W (mm)	Pin1 Quadrant
TCA6408PWR	TSSOP	PW	16	2000	330.0	12.4	7.0	5.6	1.6	8.0	12.0	Q1
TCA6408RGTR	QFN	RGT	16	3000	330.0	12.4	3.3	3.3	1.1	8.0	12.0	Q2
TCA6408ZXYR	BGA MICROSTAR JUNIOR	ZXY	20	2500	330.0	12.4	2.8	3.3	1.0	4.0	12.0	Q2



**TAPE AND REEL BOX DIMENSIONS**



\*All dimensions are nominal

Device	Package Type	Package Drawing	Pins	SPQ	Length (mm)	Width (mm)	Height (mm)
TCA6408PWR	TSSOP	PW	16	2000	346.0	346.0	29.0
TCA6408RGTR	QFN	RGT	16	3000	346.0	346.0	29.0
TCA6408ZXYR	BGA MICROSTAR JUNIOR	ZXY	20	2500	340.5	338.1	20.6

PW (R-PDSO-G\*\*)

PLASTIC SMALL-OUTLINE PACKAGE

14 PINS SHOWN



4040064/F 01/97

- NOTES: A. All linear dimensions are in millimeters.  
 B. This drawing is subject to change without notice.  
 C. Body dimensions do not include mold flash or protrusion not to exceed 0,15.  
 D. Falls within JEDEC MO-153

RGT (S-PQFP-N16)

PLASTIC QUAD FLATPACK

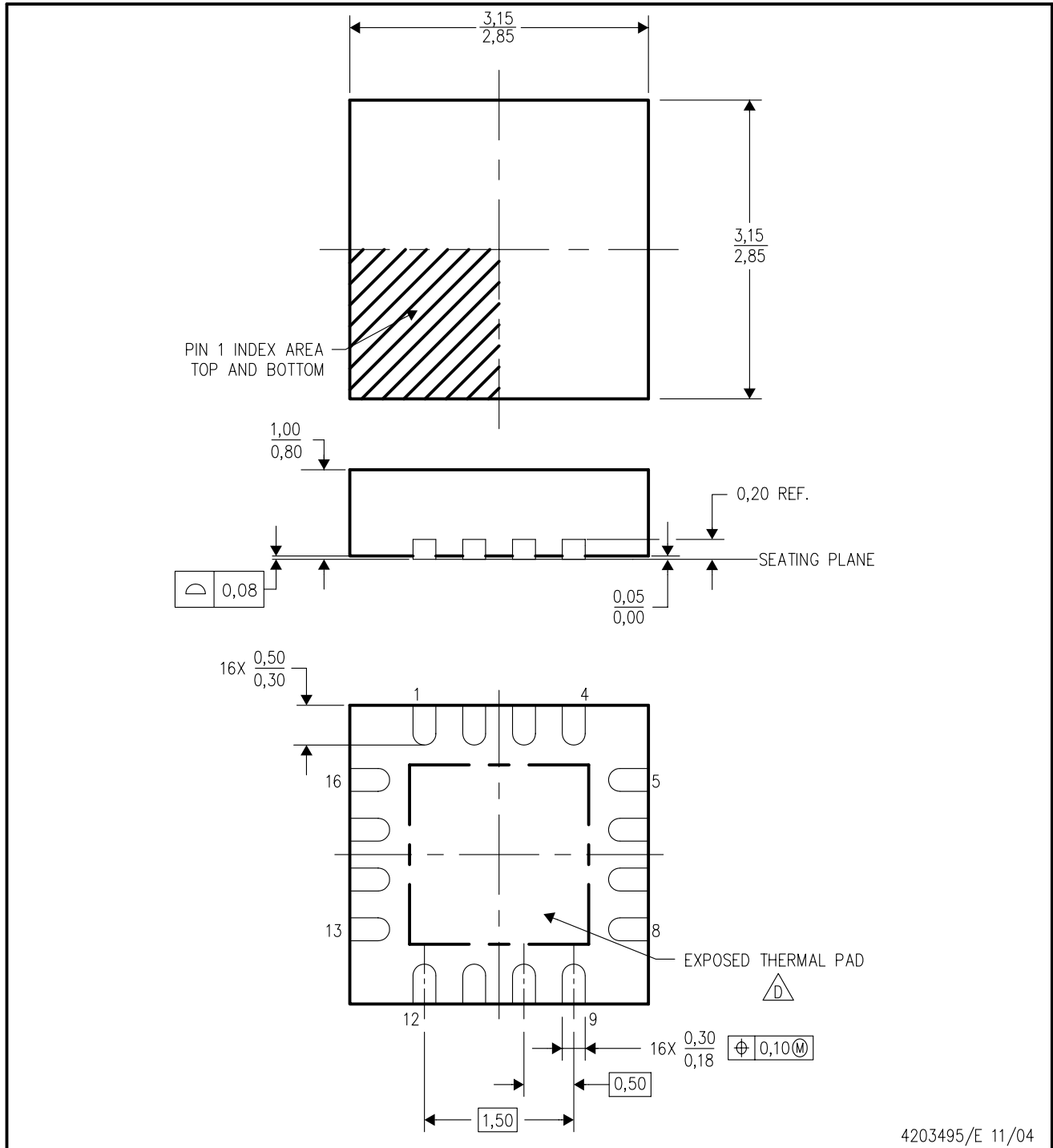

4203495/E 11/04

- NOTES:
- A. All linear dimensions are in millimeters. Dimensioning and tolerancing per ASME Y14.5M-1994.
  - B. This drawing is subject to change without notice.
  - C. Quad Flatpack, No-leads (QFN) package configuration.
  - $\triangle D$  The package thermal pad must be soldered to the board for thermal and mechanical performance. See the Product Data Sheet for details regarding the exposed thermal pad dimensions.
  - E. Falls within JEDEC MO-220.

**THERMAL INFORMATION**

This package incorporates an exposed thermal pad that is designed to be attached directly to an external heatsink. The thermal pad must be soldered directly to the printed circuit board (PCB). After soldering, the PCB can be used as a heatsink. In addition, through the use of thermal vias, the thermal pad can be attached directly to the appropriate copper plane shown in the electrical schematic for the device, or alternatively, can be attached to a special heatsink structure designed into the PCB. This design optimizes the heat transfer from the integrated circuit (IC).

For information on the Quad Flatpack No-Lead (QFN) package and its advantages, refer to Application Report, Quad Flatpack No-Lead Logic Packages, Texas Instruments Literature No. SCBA017. This document is available at [www.ti.com](http://www.ti.com).

The exposed thermal pad dimensions for this package are shown in the following illustration.

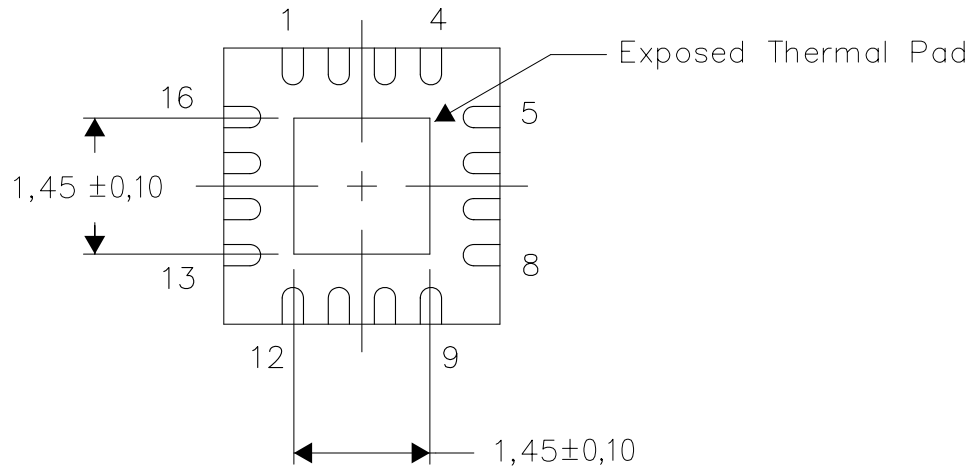

Bottom View

NOTE: All linear dimensions are in millimeters

Exposed Thermal Pad Dimensions

RGT (S-PQFP-N16)

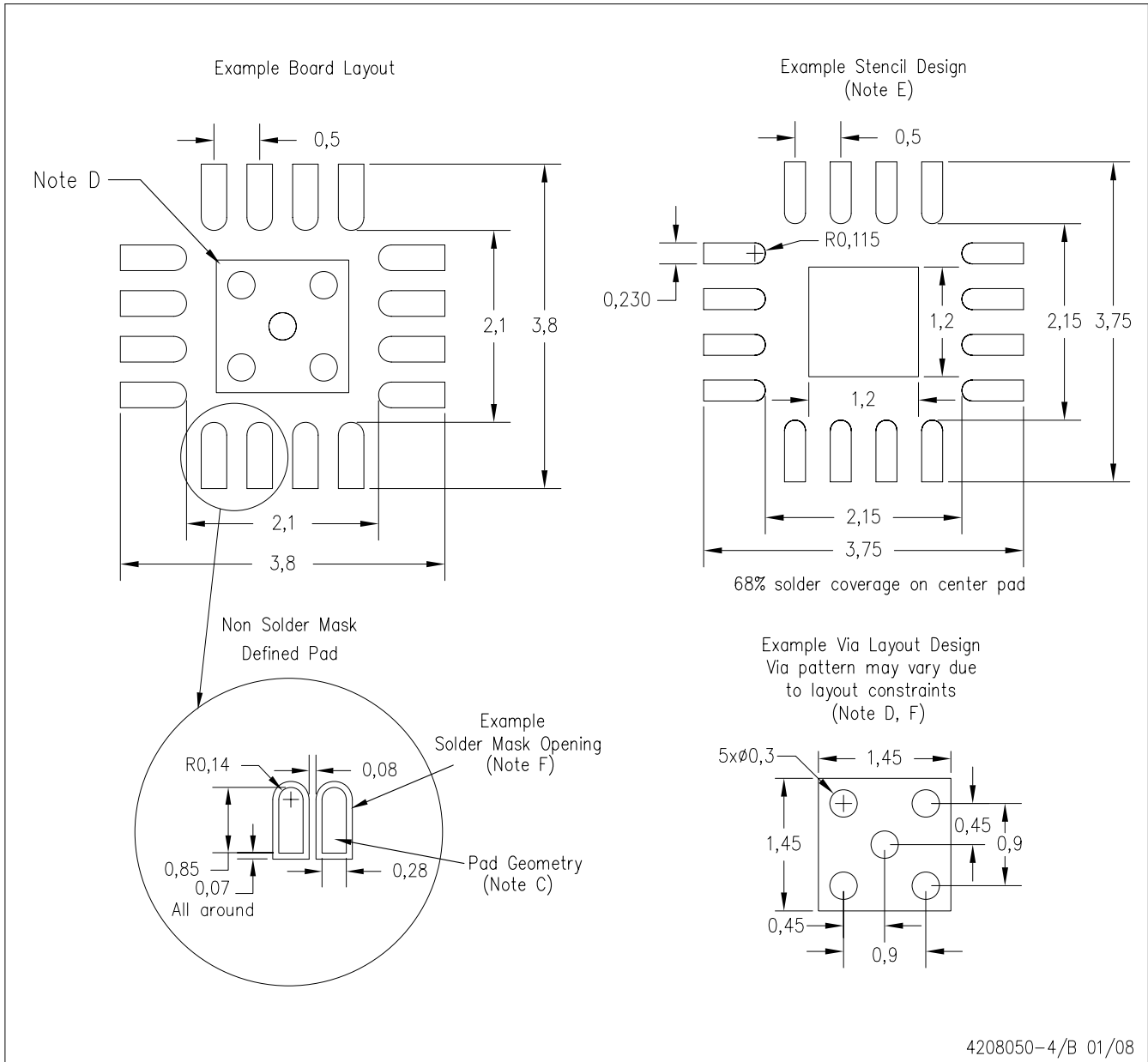

- NOTES:
- All linear dimensions are in millimeters.
  - This drawing is subject to change without notice.
  - Publication IPC-7351 is recommended for alternate designs.
  - This package is designed to be soldered to a thermal pad on the board. Refer to Application Note, Quad Flat-Pack Packages, Texas Instruments Literature No. SCBA017, SLUA271, and also the Product Data Sheets for specific thermal information, via requirements, and recommended board layout. These documents are available at [www.ti.com](http://www.ti.com) <<http://www.ti.com>>.
  - Laser cutting apertures with trapezoidal walls and also rounding corners will offer better paste release. Customers should contact their board assembly site for stencil design recommendations. Refer to IPC 7525 for stencil design considerations.
  - Customers should contact their board fabrication site for minimum solder mask web tolerances between signal pads.

ZXY (S-PBGA-N20)

PLASTIC BALL GRID ARRAY

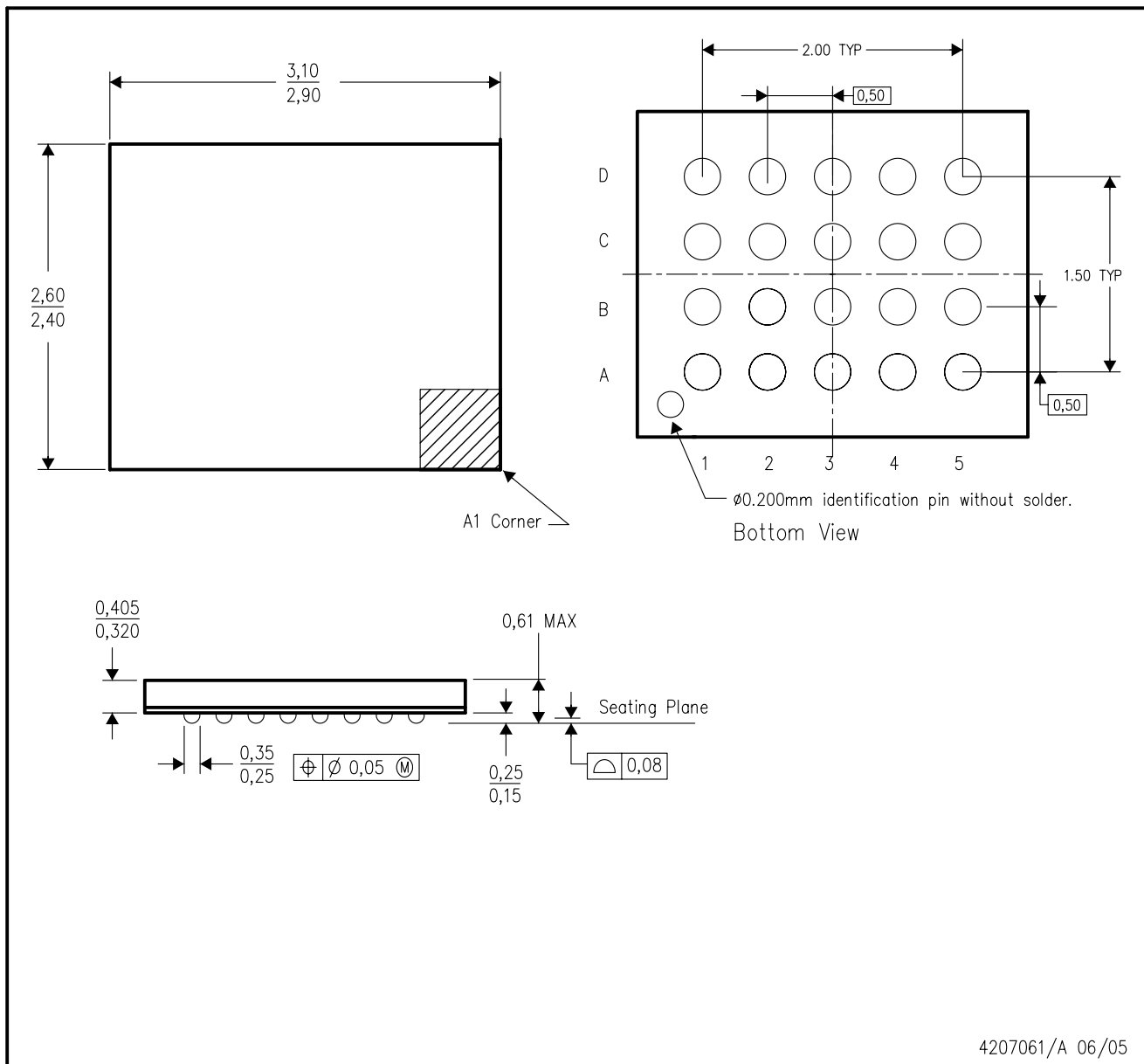

- NOTES:
- A. All linear dimensions are in millimeters.
  - B. This drawing is subject to change without notice.
  - C. This package is a lead-free solder ball design.

## IMPORTANT NOTICE

Texas Instruments Incorporated and its subsidiaries (TI) reserve the right to make corrections, modifications, enhancements, improvements, and other changes to its products and services at any time and to discontinue any product or service without notice. Customers should obtain the latest relevant information before placing orders and should verify that such information is current and complete. All products are sold subject to TI's terms and conditions of sale supplied at the time of order acknowledgment.

TI warrants performance of its hardware products to the specifications applicable at the time of sale in accordance with TI's standard warranty. Testing and other quality control techniques are used to the extent TI deems necessary to support this warranty. Except where mandated by government requirements, testing of all parameters of each product is not necessarily performed.

TI assumes no liability for applications assistance or customer product design. Customers are responsible for their products and applications using TI components. To minimize the risks associated with customer products and applications, customers should provide adequate design and operating safeguards.

TI does not warrant or represent that any license, either express or implied, is granted under any TI patent right, copyright, mask work right, or other TI intellectual property right relating to any combination, machine, or process in which TI products or services are used. Information published by TI regarding third-party products or services does not constitute a license from TI to use such products or services or a warranty or endorsement thereof. Use of such information may require a license from a third party under the patents or other intellectual property of the third party, or a license from TI under the patents or other intellectual property of TI.

Reproduction of TI information in TI data books or data sheets is permissible only if reproduction is without alteration and is accompanied by all associated warranties, conditions, limitations, and notices. Reproduction of this information with alteration is an unfair and deceptive business practice. TI is not responsible or liable for such altered documentation. Information of third parties may be subject to additional restrictions.

Resale of TI products or services with statements different from or beyond the parameters stated by TI for that product or service voids all express and any implied warranties for the associated TI product or service and is an unfair and deceptive business practice. TI is not responsible or liable for any such statements.

TI products are not authorized for use in safety-critical applications (such as life support) where a failure of the TI product would reasonably be expected to cause severe personal injury or death, unless officers of the parties have executed an agreement specifically governing such use. Buyers represent that they have all necessary expertise in the safety and regulatory ramifications of their applications, and acknowledge and agree that they are solely responsible for all legal, regulatory and safety-related requirements concerning their products and any use of TI products in such safety-critical applications, notwithstanding any applications-related information or support that may be provided by TI. Further, Buyers must fully indemnify TI and its representatives against any damages arising out of the use of TI products in such safety-critical applications.

TI products are neither designed nor intended for use in military/aerospace applications or environments unless the TI products are specifically designated by TI as military-grade or "enhanced plastic." Only products designated by TI as military-grade meet military specifications. Buyers acknowledge and agree that any such use of TI products which TI has not designated as military-grade is solely at the Buyer's risk, and that they are solely responsible for compliance with all legal and regulatory requirements in connection with such use.

TI products are neither designed nor intended for use in automotive applications or environments unless the specific TI products are designated by TI as compliant with ISO/TS 16949 requirements. Buyers acknowledge and agree that, if they use any non-designated products in automotive applications, TI will not be responsible for any failure to meet such requirements.

Following are URLs where you can obtain information on other Texas Instruments products and application solutions:

### Products

Amplifiers	<a href="http://amplifier.ti.com">amplifier.ti.com</a>
Data Converters	<a href="http://dataconverter.ti.com">dataconverter.ti.com</a>
DSP	<a href="http://dsp.ti.com">dsp.ti.com</a>
Clocks and Timers	<a href="http://www.ti.com/clocks">www.ti.com/clocks</a>
Interface	<a href="http://interface.ti.com">interface.ti.com</a>
Logic	<a href="http://logic.ti.com">logic.ti.com</a>
Power Mgmt	<a href="http://power.ti.com">power.ti.com</a>
Microcontrollers	<a href="http://microcontroller.ti.com">microcontroller.ti.com</a>
RFID	<a href="http://www.ti-rfid.com">www.ti-rfid.com</a>
RF/IF and ZigBee® Solutions	<a href="http://www.ti.com/lprf">www.ti.com/lprf</a>

### Applications

Audio	<a href="http://www.ti.com/audio">www.ti.com/audio</a>
Automotive	<a href="http://www.ti.com/automotive">www.ti.com/automotive</a>
Broadband	<a href="http://www.ti.com/broadband">www.ti.com/broadband</a>
Digital Control	<a href="http://www.ti.com/digitalcontrol">www.ti.com/digitalcontrol</a>
Medical	<a href="http://www.ti.com/medical">www.ti.com/medical</a>
Military	<a href="http://www.ti.com/military">www.ti.com/military</a>
Optical Networking	<a href="http://www.ti.com/opticalnetwork">www.ti.com/opticalnetwork</a>
Security	<a href="http://www.ti.com/security">www.ti.com/security</a>
Telephony	<a href="http://www.ti.com/telephony">www.ti.com/telephony</a>
Video & Imaging	<a href="http://www.ti.com/video">www.ti.com/video</a>
Wireless	<a href="http://www.ti.com/wireless">www.ti.com/wireless</a>

Mailing Address: Texas Instruments, Post Office Box 655303, Dallas, Texas 75265  
Copyright © 2008, Texas Instruments Incorporated