

Zener Diodes with Surge Current Specification

Features

- Glass passivated junction
- Hermetically sealed package
- Clamping time in picoseconds
- Lead (Pb)-free component
- Component in accordance to RoHS 2002/95/EC and WEEE 2002/96/EC

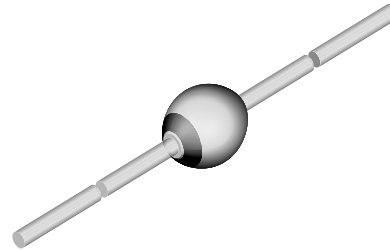

949539

Applications

Medium power voltage regulators and medium power transient suppression circuits

Mechanical Data

Case: SOD-57 Sintered glass case

Weight: approx. 369 mg

Packaging Codes/Options:

TAP / 5 k Ammopack (52 mm tape) / 25 k/box

TR / 5 k 10" reel

Absolute Maximum Ratings

$T_{amb} = 25\text{ }^{\circ}\text{C}$, unless otherwise specified

Parameter	Test condition	Symbol	Value	Unit
Power dissipation	$l = 10\text{ mm}, T_L = 25\text{ }^{\circ}\text{C}$	P_V	3.25	W
	$T_{amb} = 25\text{ }^{\circ}\text{C}$	P_V	1.3	W
Repetitive peak reverse power dissipation		P_{ZRM}	10	W
Non repetitive peak surge power dissipation	$t_p = 100\text{ }\mu\text{s}, T_j = 25\text{ }^{\circ}\text{C}$	P_{ZSM}	600	W
Junction temperature		T_j	175	$^{\circ}\text{C}$
Storage temperature range		T_{stg}	- 65 to + 175	$^{\circ}\text{C}$

Thermal Characteristics

$T_{amb} = 25\text{ }^{\circ}\text{C}$, unless otherwise specified

Parameter	Test condition	Symbol	Value	Unit
Junction ambient	$l = 10\text{ mm}, T_L = \text{constant}$	R_{thJA}	46	K/W
	on PC board with spacing 25 mm	R_{thJA}	100	K/W

Electrical Characteristics

$T_{amb} = 25\text{ }^{\circ}\text{C}$, unless otherwise specified

Parameter	Test condition	Symbol	Min	Typ.	Max	Unit
Forward voltage	$I_F = 0.5\text{ A}$	V_F			1.2	V

Electrical Characteristics

BZT03C...

Partnumber	Zener Voltage Range			Dynamic Resistance		Test Current	Temperature Coefficient of Zener Voltage		Reverse Leakage Current		Clamping		Stand-off	
	$V_Z @ I_{ZT}$			r_{zj} and $TK_{VZ} @ I_Z$		I_{ZT}	$TC_{VZ} @ I_{ZT}$		$I_R @ V_R$		$V_{(CL)R}^{1)} @ I_{RMS}$		$I_R @ V_R^{2)}$	
	V			Ω		mA	%K		μA	V	V	A	μA	V
	min	typ	max	typ	max		min	max	max		max		max	
BZT03C6V2	5.8	6.2	6.6	1	2	100	0	0.07	1500	4.7	9.3	34.0	3000	5.1
BZT03C6V8	6.4	6.8	7.2	1	2	100	0	0.07	1000	5.1	10.2	31.0	2000	5.6
BZT03C7V5	7	7.5	7.9	1	2	100	0	0.07	750	5.6	11.3	26.5	1500	6.2
BZT03C8V2	7.7	8.2	8.7	1	2	100	0.03	0.08	600	6.2	12.3	24.4	1200	6.8
BZT03C9V1	8.5	9.1	9.6	2	4	50	0.03	0.08	20	6.8	13.3	22.7	50	7.5
BZT03C10	9.4	10	10.6	2	4	50	0.05	0.09	10	7.5	14.8	20.3	20	8.2
BZT03C11	10.4	11	11.6	4	7	50	0.05	0.1	4	8.2	15.7	19.1	5	9.1
BZT03C12	11.4	12	12.7	4	7	50	0.05	0.1	3	9.1	17.0	17.7	5	10
BZT03C13	12.4	13	14.1	5	10	50	0.05	0.1	2	10	18.9	15.9	5	11
BZT03C15	13.8	15	15.6	5	10	50	0.05	0.1	1	11	20.9	14.4	5	12
BZT03C16	15.3	16	17.1	6	15	25	0.06	0.11	1	12	22.9	13.1	5	13
BZT03C18	16.8	18	19.1	6	15	25	0.06	0.11	1	13	25.6	11.7	5	15
BZT03C20	18.8	20	21.2	6	15	25	0.06	0.11	1	15	28.4	10.6	5	16
BZT03C22	20.8	22	23.3	6	15	25	0.06	0.11	1	16	31.0	9.7	5	18
BZT03C24	22.8	24	25.6	7	15	25	0.06	0.11	1	18	33.8	8.9	5	20
BZT03C27	25.1	27	28.9	7	15	25	0.06	0.11	1	20	38.1	7.9	5	22
BZT03C30	28	30	32	8	15	25	0.06	0.11	1	22	42.2	7.1	5	24
BZT03C33	31	33	35	8	15	25	0.06	0.11	1	24	46.2	6.5	5	27
BZT03C36	34	36	38	21	40	10	0.06	0.11	1	27	50.1	6.0	5	30
BZT03C39	37	39	41	21	40	10	0.06	0.11	1	30	54.1	5.5	5	33
BZT03C43	40	43	46	24	45	10	0.07	0.12	1	33	60.7	4.9	5	36
BZT03C47	44	47	50	24	45	10	0.07	0.12	1	36	65.5	4.6	5	39
BZT03C51	48	51	54	25	60	10	0.07	0.12	1	39	70.8	4.2	5	43
BZT03C56	52	56	60	25	60	10	0.07	0.12	1	43	78.6	3.8	5	47
BZT03C62	58	62	66	25	80	10	0.08	0.13	1	47	86.5	3.5	5	51
BZT03C68	64	68	72	25	80	10	0.08	0.13	1	51	94.4	3.2	5	56
BZT03C75	70	75	79	30	100	10	0.08	0.13	1	56	103.5	2.9	5	62
BZT03C82	77	82	87	30	100	10	0.08	0.13	1	62	114	2.6	5	68
BZT03C91	85	91	96	60	200	5	0.09	0.13	1	68	126	2.4	5	75
BZT03C100	94	100	106	60	200	5	0.09	0.13	1	75	139	2.2	5	82
BZT03C110	104	110	116	80	250	5	0.09	0.13	1	82	152	2.0	5	91
BZT03C120	114	120	127	80	250	5	0.09	0.13	1	91	167	1.8	5	100
BZT03C130	124	130	141	110	300	5	0.09	0.13	1	100	185	1.6	5	110
BZT03C150	138	150	156	130	300	5	0.09	0.13	1	110	204	1.5	5	120
BZT03C160	153	160	171	150	350	5	0.09	0.13	1	120	224	1.3	5	130
BZT03C180	168	180	191	180	400	5	0.09	0.13	1	130	249	1.2	5	150
BZT03C200	188	200	212	200	500	5	0.09	0.13	1	150	276	1.1	5	160
BZT03C220	208	220	233	350	750	2	0.09	0.13	1	160	305	1.0	5	180
BZT03C240	228	240	256	400	850	2	0.09	0.13	1	180	336	0.9	5	200
BZT03C270	251	270	289	450	1000	2	0.09	0.13	1	200	380	0.8	5	220
BZT03C300	280	300	320	450	1000	2	0.09	0.13	1	220	419	0.72	5	240

1) 10/1000 exp. falling pulse $t_p = 1000 \mu s$ down to 50 %

2) Stand-off voltage = recommended supply voltage



Electrical Characteristics

BZT03D...

Partnumber	Zener Voltage Range			Dynamic Resistance		Test Current	Temperature Coefficient of Zener Voltage		Reverse Leakage Current		Clamping		Stand-off	
	$V_Z @ I_{ZT}$			r_{zj} and $TK_{VZ} @ I_Z$		I_{ZT}	$TC_{VZ} @ I_{ZT}$		$I_R @ V_R$		$V_{(CL)R}^{(1)} @ I_{RMS}$		$I_R @ V_R^{(2)}$	
	V			Ω		mA	%/K		μA	V	V	A	μA	V
	min	typ	max	typ	max		min	max	max		max		max	
BZT03D6V2	5.6	6.2	6.8	1	2	100	0	0.07	1500	4.4	9.5	34.0	3000	4.8
BZT03D6V8	6.1	6.8	7.5	1	2	100	0	0.07	1000	4.8	10.5	31.0	2000	5.3
BZT03D7V5	6.75	7.5	8.25	1	2	100	0	0.07	750	5.3	11.6	26.5	1500	5.9
BZT03D8V2	7.4	8.2	9	1	2	100	0.03	0.08	600	5.9	12.6	24.4	1200	6.5
BZT03D9V1	8.2	9.1	10	2	4	50	0.03	0.08	20	6.5	13.7	22.7	50	7.1
BZT03D10	9	10	11	2	4	50	0.05	0.09	10	7.1	15.2	20.3	20	7.9
BZT03D11	9.9	11	12.1	4	7	50	0.05	0.1	4	7.9	16.2	19.1	5	8.6
BZT03D12	10.8	12	13.2	4	7	50	0.05	0.1	3	8.6	17.5	17.7	5	9.3
BZT03D13	11.7	13	14.3	5	10	50	0.05	0.1	2	9.3	19.1	15.9	5	10.6
BZT03D15	13.5	15	16.5	5	10	50	0.05	0.1	1	10.6	21.8	14.4	5	11.6
BZT03D16	14.4	16	17.6	6	15	25	0.06	0.11	1	11.6	23.4	13.1	5	12.6
BZT03D18	16.2	18	19.8	6	15	25	0.06	0.11	1	12.6	26.3	11.7	5	14.4
BZT03D20	18	20	22	6	15	25	0.06	0.11	1	14.4	29.2	10.6	5	15.8
BZT03D22	29.8	22	24.2	6	15	25	0.06	0.11	1	15.8	31.9	9.7	5	17.2
BZT03D24	21.6	24	26.4	7	15	25	0.06	0.11	1	17.2	34.6	8.9	5	19.4
BZT03D27	24.3	27	29.7	7	15	25	0.06	0.11	1	19.4	39	7.9	5	21.5
BZT03D30	27	30	33	8	15	25	0.06	0.11	1	21.5	43.5	7.1	5	23.5
BZT03D33	29.7	33	36.3	8	15	25	0.06	0.11	1	23.5	47.5	6.5	5	25.8
BZT03D36	32.4	36	39.6	21	40	10	0.06	0.11	1	25.8	51.5	6.0	5	28
BZT03D39	35.1	39	42.9	21	40	10	0.06	0.11	1	28	56	5.5	5	31
BZT03D43	38.7	43	47.3	24	45	10	0.07	0.12	1	31	62	4.9	5	33.5
BZT03D47	42.3	47	51.7	24	45	10	0.07	0.12	1	33.5	67.5	4.6	5	36.5
BZT03D51	45.9	51	56.1	25	60	10	0.07	0.12	1	36.5	73	4.2	5	40
BZT03D56	50.4	56	61.6	25	60	10	0.07	0.12	1	40	81	3.8	5	44.5
BZT03D62	55.8	62	68.2	25	80	10	0.08	0.13	1	44.5	89	3.5	5	49
BZT03D68	61.2	68	74.8	25	80	10	0.08	0.13	1	49	97	3.2	5	54
BZT03D75	67.5	75	82.5	30	100	10	0.08	0.13	1	54	107	2.9	5	59
BZT03D82	73.8	82	90.2	30	100	10	0.08	0.13	1	59	117	2.6	5	65
BZT03D91	81.9	91	100	60	200	5	0.09	0.13	1	65	130	2.4	5	71
BZT03D100	90	100	110	60	200	5	0.09	0.13	1	71	143	2.2	5	79
BZT03D110	99	110	121	80	250	5	0.09	0.13	1	79	157	2.0	5	86
BZT03D120	108	120	132	80	250	5	0.09	0.13	1	86	172	1.8	5	93
BZT03D130	117	130	143	110	300	5	0.09	0.13	1	93	187	1.6	5	106
BZT03D150	135	150	165	130	300	5	0.09	0.13	1	106	213	1.5	5	116
BZT03D160	144	160	176	150	350	5	0.09	0.13	1	116	229	1.3	5	126
BZT03D180	162	180	198	180	400	5	0.09	0.13	1	126	256	1.2	5	144
BZT03D200	180	200	220	200	500	5	0.09	0.13	1	144	284	1.1	5	158
BZT03D220	198	220	242	350	750	2	0.09	0.13	1	158	314	1.0	5	172
BZT03D240	216	240	264	400	850	2	0.09	0.13	1	172	364	0.9	5	194
BZT03D270	243	270	297	450	1000	2	0.09	0.13	1	194	388	0.8	5	215

¹⁾ 10/1000 exp. falling pulse tp = 1000 μs down to 50 %

²⁾ Stand-off voltage = recommended supply voltage

Typical Characteristics (T_{amb} = 25 °C unless otherwise specified)

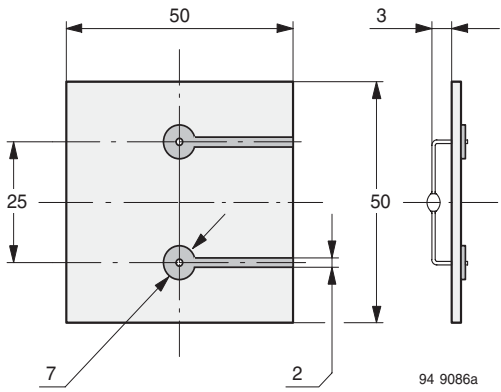

Figure 1. Epoxy Glass Hard Tissue, Board Thickness 1.5 mm, $R_{thJA} \leq 100$ K/W

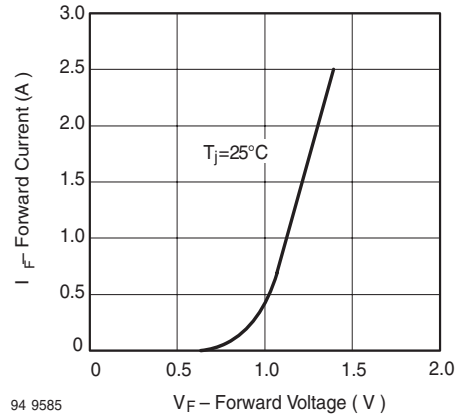

Figure 3. Forward Current vs. Forward Voltage

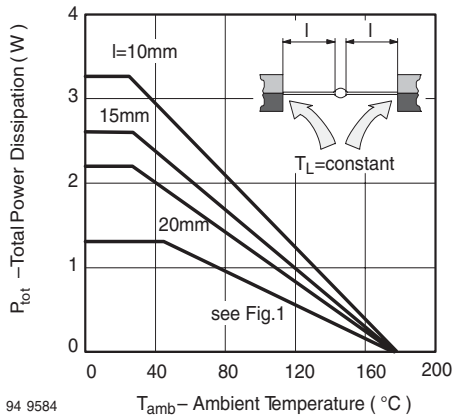

Figure 2. Total Power Dissipation vs. Ambient Temperature

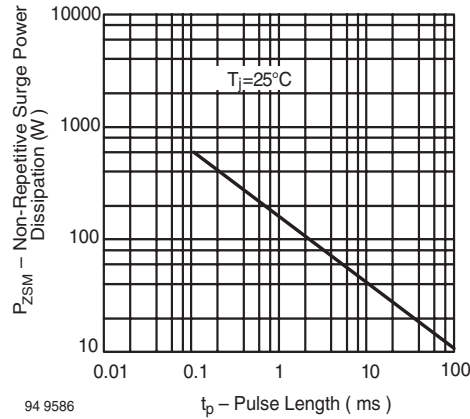
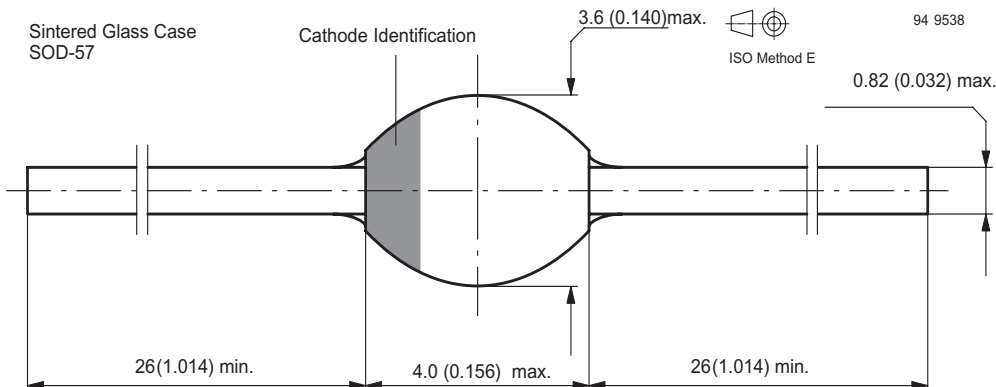

Figure 4. Non Repetitive Surge Power Dissipation vs. Pulse Length

Package Dimensions in mm (Inches)





Ozone Depleting Substances Policy Statement

It is the policy of Vishay Semiconductor GmbH to

1. Meet all present and future national and international statutory requirements.
2. Regularly and continuously improve the performance of our products, processes, distribution and operating systems with respect to their impact on the health and safety of our employees and the public, as well as their impact on the environment.

It is particular concern to control or eliminate releases of those substances into the atmosphere which are known as ozone depleting substances (ODSs).

The Montreal Protocol (1987) and its London Amendments (1990) intend to severely restrict the use of ODSs and forbid their use within the next ten years. Various national and international initiatives are pressing for an earlier ban on these substances.

Vishay Semiconductor GmbH has been able to use its policy of continuous improvements to eliminate the use of ODSs listed in the following documents.

1. Annex A, B and list of transitional substances of the Montreal Protocol and the London Amendments respectively
2. Class I and II ozone depleting substances in the Clean Air Act Amendments of 1990 by the Environmental Protection Agency (EPA) in the USA
3. Council Decision 88/540/EEC and 91/690/EEC Annex A, B and C (transitional substances) respectively.

Vishay Semiconductor GmbH can certify that our semiconductors are not manufactured with ozone depleting substances and do not contain such substances.

We reserve the right to make changes to improve technical design and may do so without further notice.

Parameters can vary in different applications. All operating parameters must be validated for each customer application by the customer. Should the buyer use Vishay Semiconductors products for any unintended or unauthorized application, the buyer shall indemnify Vishay Semiconductors against all claims, costs, damages, and expenses, arising out of, directly or indirectly, any claim of personal damage, injury or death associated with such unintended or unauthorized use.

Vishay Semiconductor GmbH, P.O.B. 3535, D-74025 Heilbronn, Germany



Notice

Specifications of the products displayed herein are subject to change without notice. Vishay Intertechnology, Inc., or anyone on its behalf, assumes no responsibility or liability for any errors or inaccuracies.

Information contained herein is intended to provide a product description only. No license, express or implied, by estoppel or otherwise, to any intellectual property rights is granted by this document. Except as provided in Vishay's terms and conditions of sale for such products, Vishay assumes no liability whatsoever, and disclaims any express or implied warranty, relating to sale and/or use of Vishay products including liability or warranties relating to fitness for a particular purpose, merchantability, or infringement of any patent, copyright, or other intellectual property right.

The products shown herein are not designed for use in medical, life-saving, or life-sustaining applications. Customers using or selling these products for use in such applications do so at their own risk and agree to fully indemnify Vishay for any damages resulting from such improper use or sale.