

MODEL 39
 15 mm Single-Turn Trimmer
 Dust Proof
 Carbon Element
 RoHS Compliant

New Product



STYLES AVAILABLE

Top Adjust	39P
Side Adjust	39W

ELECTRICAL¹

Resistance Range	100 to 1,000,000 Ohms
Standard Resistance Tolerance	± 30%, (±20% and ±10% available)
Input Voltage, Maximum	250 Vdc
Power rating, Watts	Linear :0.25W, others : 0.15W, at 50°C
End Resistance, Maximum	< 500K - 2 ohms and ≥ 500K - 1%
Actual Electrical Travel	250° ±20°
Insulation Resistance, Minimum	100 Megohms
Resolution	Essentially infinite
Contact Resistance Variation	5% Max.

MECHANICAL

Torque, Maximum	2 in. oz.
Weight, Approx.	0.01 oz.
Wiper Position	Approx. 50%

ENVIRONMENTAL

Operating Temperature Range	-25°C to +70°C
Rotational Life, 500 Cycles	±3% ΔR
Load Life, 0.25W, 1000 Hours, 50°C	±5% ΔR
Resistance to Solder Heat	260°C for 3 sec.
Aqueous cleaning not recommended	

¹ Specifications subject to change without notice.

MODEL 39

ORDERING INFORMATION²

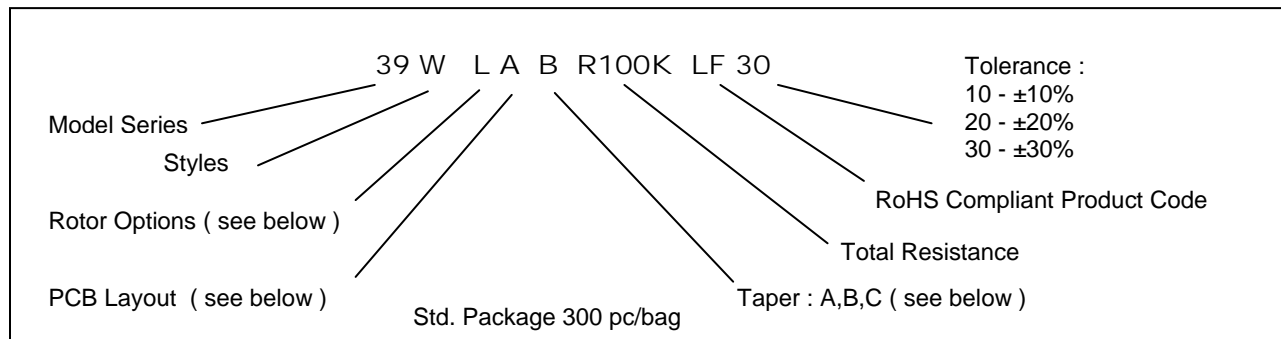

Rotor Options

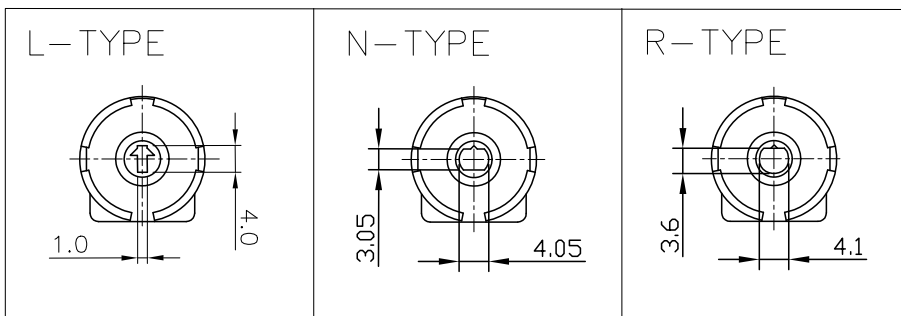

PCB Layout Options (39P)

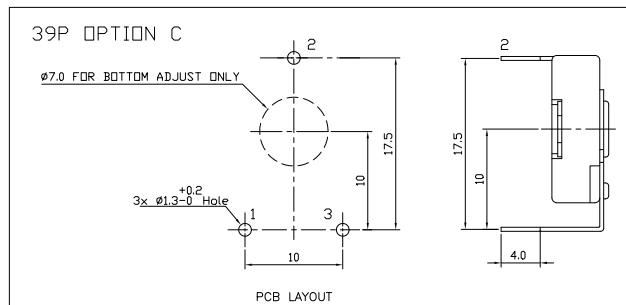
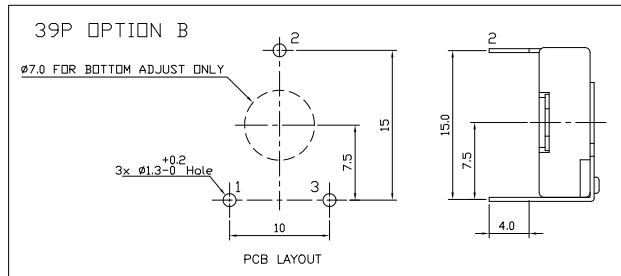
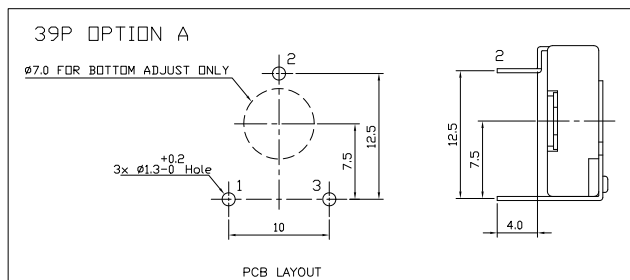

² Contact our customer service for custom designs and features.

MODEL 39

PCB Layout Options (39W)

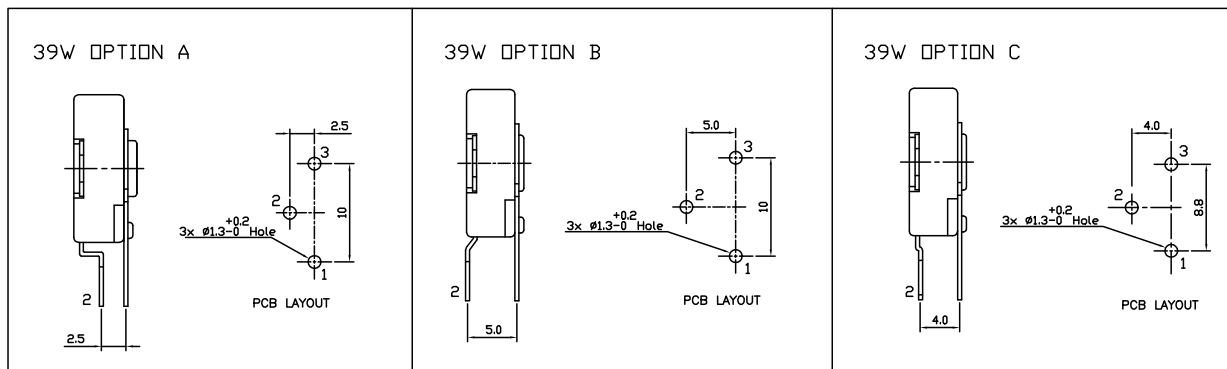

Taper Options

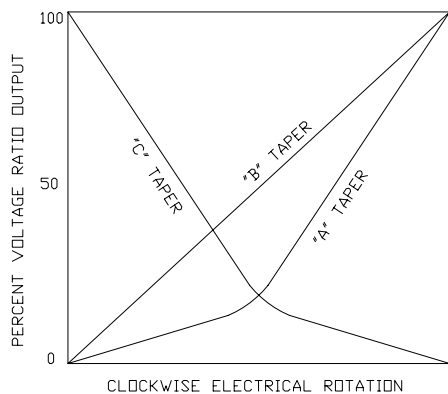

CIRCUIT DIAGRAM

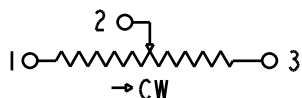

STANDARD RESISTANCE VALUES AND MARKING

100 500 1K 2K 5K 10K 20K 50K 100K 200K 500K 1MEG

MODEL 39

OUTLINE DRAWING³

Model 39P (Top Adjust)

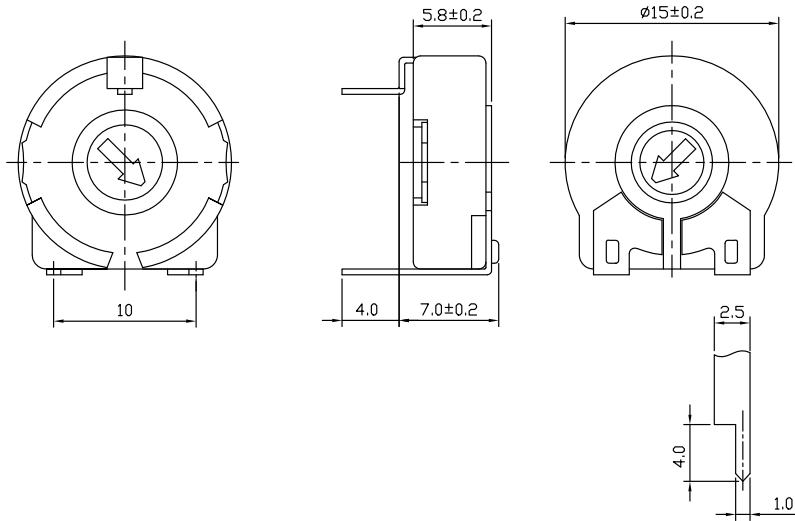

Model 39W (Side Adjust)

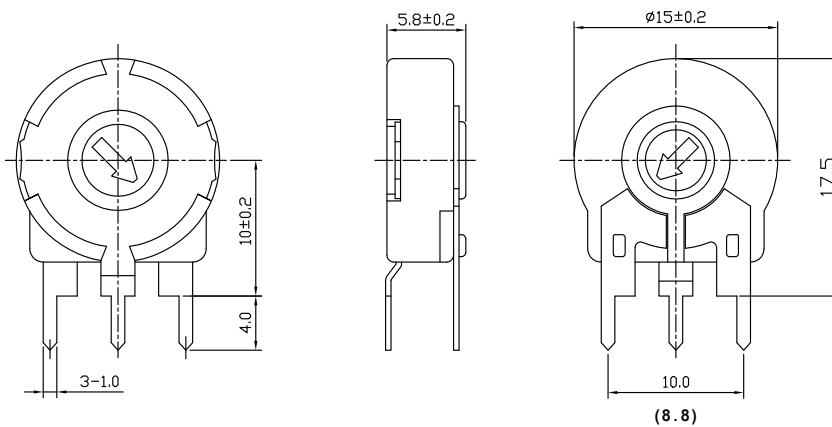

³ Dimensions are in millimeters, Tolerances are ±.025 mm unless otherwise stated.