

Delivery address: Mackenrodtstraße 14,
36039 Fulda, Germany
Postal address: 36035 Fulda, Germany
Phone: +49 661 6003-0
Fax: +49 661 6003-607
E-mail: mail@jumo.net
Internet: www.jumo.net

JUMO House
Temple Bank, Riverway
Harlow, Essex CM 20 2TT, UK
Phone: +44 1279 635533
Fax: +44 1279 635262
E-mail: sales@jumo.co.uk
Internet: www.jumo.co.uk

885 Fox Chase, Suite 103
Coatesville PA 19320, USA
Phone: 610-380-8002
1-800-554-JUMO
Fax: 610-380-8009
E-mail: info@JumoUSA.com
Internet: www.JumoUSA.com



LOGOPRINT® 500 / 500 junior



Printing recorder with text printing and 24-character LED dot-matrix display

Brief description

The LOGOPRINT recorder family consists of two printing recorders, the LOGOPRINT 500 and the LOGOPRINT 500 junior.

LOGOPRINT 500 (Type 954012)

The printing recorder is equipped with 3 or (optionally) 6 measurement inputs, which are electrically isolated from one another. The evaluation of the measurement traces of the printing recorder can be assisted by extensive text printing. The recorder can be programmed either by using the 8 keys on the front of the instrument or through a PC setup program.

Thermocouples, resistance thermometers, resistance transmitters, potentiometers, voltages or currents (standard signals) are possible as input signals. The appropriate linearizations are carried out automatically, but can also be adapted to customer-specific linearizations with the help of the PC setup program.

Further outstanding features of the LOGOPRINT 500, which are already included in the basic version, are four open-collector outputs for signaling infringements of limits and faults, eight event traces, as well as peak value recording.

The color assignments (measurement traces and texts) are freely programmable via the PC setup program, which is available as an accessory.

LOGOPRINT 500 junior (Type 954013)

This recorder is equipped with 6 measurement inputs, which are electrically isolated from one another. It can also support the evaluation of the measurement traces with printed text (limited). Programming is only possible via the keys. Voltages and currents (standard signals) are possible as input signals. There are no open-collector outputs, no event traces, no peak value recording and no extra codes.

Overview of functions

	Type 954012	Type 954013
Analog inputs (configurable and isolated)	3 or 6 inputs for: - thermocouples - resistance thermometers - resistance transmitters - potentiometers - voltage and current	6 inputs for: - voltage - current
8 logic inputs	available as extra code	not available
Outputs	- 4 open-collector outputs available as extra code: - interface for 8 relay outputs - supply for 2-wire transmitter	not available
Recording	- measurement traces - text printing - event traces	- measurement traces - text printing (limited)
Setup interface	for configuration and parameter setting via PC	not available
RS422/RS485 interface	extra code for the data transfer from and to the recorder	not available
Supply voltage	110 — 240V AC +10/-15% 48 — 63Hz 20 — 53V AC/DC ±0% 48 — 63Hz	110 — 240V AC +10/-15% 48 — 63Hz 20 — 53V AC/DC ±0% 48 — 63Hz

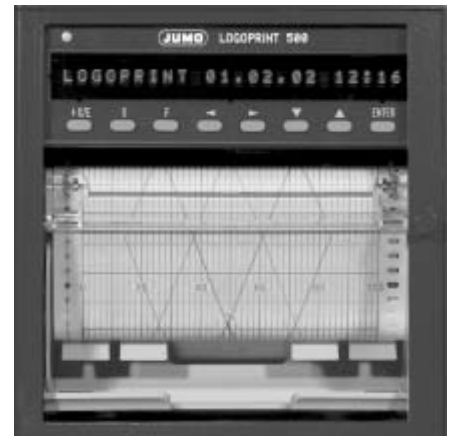

Type 954012

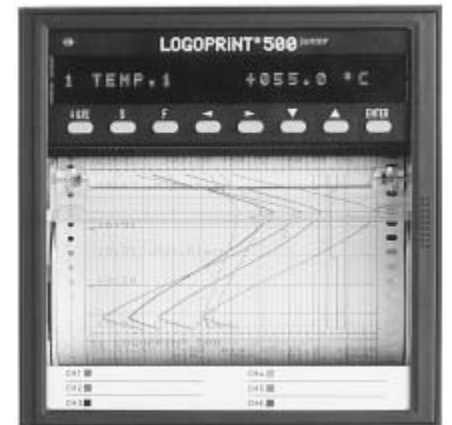

Type 954013

Features of the Type 954012

- Limit monitoring
- Event traces
- Four open-collector outputs
- Peak value recording
- Extensive text printing
- Statistics (report) with minimum, maximum and mean values
- Event- and time-controlled chart speed
- Math and logic module (PC setup program is required)
- Universal chart cassette

Technical data

Thermocouple input (Type 954012)

Designation	Range	Linearisation accuracy ¹
Fe-Con L DIN 43 710 ²	-200 to + 900°C	±0.2%
Fe-Con J EN 60 584	-210 to +1200°C	±0.2% above -200°C
Cu-Con U DIN 43 710 ²	-200 to + 600°C	±0.3%
Cu-Con T EN 60 584	-270 to + 400°C	±0.5% above -200°C
NiCr-Ni K EN 60 584	-270 to +1372°C	±0.2% above -150°C
NiCr-Con E EN 60 584	-270 to +1000°C	±0.2% above -200°C
NiCrSi-NiSi N EN 60 584	-270 to +1300°C	±0.2% above -150°C
Pt10Rh-Pt S EN 60 584	-50 to +1768°C	±0.5% above 0°C
Pt13Rh-Pt R EN 60 584	-50 to +1768°C	±0.5% above 0°C
Pt30Rh-Pt6Rh B EN 60 584	0 — 1820°C	±0.5% above 500°C
Shortest span	Types L, J, U, T, K, E, N: Types S, R, B:	100°C 500°C
Range start/end	freely programmable within the limits in 0.1°C steps	
Cold junction	Pt 100 internal or thermostat as external constant	
Cold junction accuracy (internal)	± 1°C	
Cold junction temperature (external)	-50 to +100°C, adjustable through setup software	
Measurement time	for 3 channels < 2sec; for 6 channels < 4sec	
Input filter	2nd order digital filter; filter constant adjustable from 0 — 50.0sec	
Features	also programmable in °F; customer-specific linearizations	

1. The linearization accuracy refers to the maximum span.
The linearization accuracy is reduced for shorter spans.

2.) invalid DIN since 1995

Resistance thermometer input (Type 954012)

	Connection	Range	Linearisation accuracy	Meas. current
Pt 100 EN 60 751	2/3-wire	-200 to +250°C	±0.6°C	500µA
	2/3-wire	-200 to +850°C	±1.0°C	250µA
	4-wire	-200 to +250°C	±0.5°C	500µA
	4-wire	-200 to +850°C	±0.8°C	250µA
Pt 100 JIS	2/3-wire	-200 to +260°C	±0.6°C	500µA
	2/3-wire	-200 to +649°C	±1.0°C	250µA
	4-wire	-200 to +260°C	±0.5°C	500µA
	4-wire	-200 to +649°C	±0.8°C	250µA
Pt 500 DIN	2/3-wire	-200 to +150°C	±0.6°C	250µA
	2/3-wire	-200 to +850°C	±1.0°C	250µA
	4-wire	-200 to +150°C	±0.5°C	250µA
	4-wire	-200 to +850°C	±0.8°C	250µA
Pt 1000 DIN	2/3-wire	-200 to +250°C	±0.6°C	500µA
	2/3-wire	-200 to +850°C	±1.0°C	250µA
	4-wire	-200 to +250°C	±0.5°C	500µA
	4-wire	-200 to +850°C	±0.8°C	250µA
Ni 100	2/3-wire	-60 to +125°C	±0.6°C	500µA
	2/3-wire	-60 to +180°C	±1.0°C	250µA
	4-wire	-60 to +125°C	±0.5°C	500µA
	4-wire	-60 to +180°C	±0.8°C	250µA
Connection type	2-, 3- or 4-wire circuit			
Shortest span	15°C			
Probe lead resistance	max. 30Ω per core for 4-wire circuit max. 20Ω per core for 2- and 3-wire circuit for Pt 100 up to 260°C max. 10Ω per core in 2-wire and 3-wire circuit			
Range start/end	freely programmable within the limits in 0.1°C steps			
Measurement time	for 3 channels < 2sec; for 6 channels < 4sec			
Input filter	2nd order digital filter; filter constant adjustable from 0 — 50sec			
Features	also programmable in °F; customer-specific linearizations			

Resistance transmitter and potentiometer input (Type 954012)

Range	Accuracy	Measuring current
up to 200Ω	±300mΩ	500μA
up to 400Ω	±600mΩ	250μA
up to 800Ω	±1Ω	250μA
up to 2000Ω	±2Ω	500μA
up to 4000Ω	±3Ω	250μA
Connection type	resistance transmitter: 3-wire circuit potentiometer: 2-, 3- or 4-wire circuit	
Shortest span	6Ω	
Probe lead resistance	max. 30Ω per core in 4-wire circuit max. 20Ω per core in 2- and 3-wire circuit up to 200Ω range: max. 10Ω per core in 2- and 3-wire circuit	
Resistance values	freely programmable within the limits in 0.1Ω steps	
Measurement time	for 3 channels < 2sec; for 6 channels < 4sec	
Input filter	2nd order digital filter; filter constant adjustable from 0 — 50.0sec	

Input for DC voltage or DC current (Type 954012 and Type 954013)

Basic range	Range	Accuracy	Input resistance
1V	-25 to +75mV	±100μV	R _E > 10 MΩ
1V	0 — 100mV	±100μV	R _E > 10 MΩ
1V	-100 to +100mV	±150μV	R _E > 10 MΩ
1V	0 — 200mV	±150μV	R _E > 10 MΩ
1V	-500 to +500mV	±1mV	R _E > 10 MΩ
1V	0 — 1V	±1mV	R _E > 10 MΩ
1V	-1 to +1V	±2mV	R _E > 10 MΩ
10V	-5 to +5V	±10mV	R _E > 0.5 MΩ
10V	0 — 10V	±10mV	R _E > 0.5 MΩ
10V	-10 to +10V	±15mV	R _E > 0.5 MΩ
Shortest span	5mV		
Range start/end	freely programmable within the limits (up to 999mV in 0.01mV steps, from 1V in 1mV steps)		
20mA	4 — 20mA	±20μA	burden voltage 2.6V max.
20mA	0 — 20mA	±20μA	burden voltage 2.6V max.
20mA	-20 to +20mA	±40μA	burden voltage 2.6V max.
Shortest span	0.5mA		
Range start/end	freely programmable within the limits in 0.1mA steps		
Measurement time	for 3 channels < 2sec; for 6 channels < 4sec		
Input filter	2nd order digital filter; filter constant adjustable from 0 — 50.0sec		
Features	for Type 954012: adjustable linearizations for thermocouples and resistance thermometers (for connection to transmitters without linearization)		

Transducer short-circuit/break

	Short-circuit ¹	Break ¹
Thermocouple	not recognized	recognized
Resistance thermometer	recognized	recognized ²
Resistance transmitter	recognized	recognized
Potentiometer	not recognized	recognized ²
Voltage up to ± 1V	not recognized	recognized
Voltage above ± 1V	not recognized	not recognized
Current	not recognized	not recognized

1. The print head is positioned to 0%, ">>>>>>" appears in the LED dot-matrix display.

2. In 4-wire circuit: only recognized at terminals 1 and 2.

Outputs (Type 954012)

Three open-collector outputs	to signal over/underlimit
One open-collector output	to signal faults (e. g. end of chart)

Printing system (Type 954012 and Type 954013)

Drive	stepper motor
Sensitivity	0.2% or better referred to 100mm writing width
Reproducibility	0.25% or better referred to 100mm writing width
Display and recording accuracy	Class 0.5 referred to range limits and basic ranges
Print head	print head with penlift function - sufficient for approx. 1 million dots (depending on the ambient temperature)
Print colors	Violet, red, black for 3-channel printing recorder and violet, red, black, green, blue, brown for 6-channel printing recorder. For Type 954012 the color assignment can be changed at will, through the setup program.
Over/underrun	electronically limited to 0 — 100mm writing width
Chart speed	programmable in the steps 0, 5, 10, 20, 60, 120, 240, 300, 360, 600, 720mm/h
Paper feed	by stepper motor and gearing
Chart cassette	cassette for roll chart and fanfold chart (with tear-off edge and paper-end switch)
Chart overall width / writing width sprocket roller spacing visible diagram length overall length	roll or fanfold chart to DIN 16 320 120mm / 100mm 110mm roll chart: 60mm; fanfold chart: 30 — 60mm roll chart: 16m or 32m; fanfold chart: 16m

Electrical data (Type 954012 and Type 954013)

Supply (SMPS)	110 — 240V AC +10/-15% AC 48 — 63Hz, or 20 — 53V ±0% AC/DC 48 — 63Hz
Electrical safety	to EN 61 010, Part 1, March 1994 overvoltage Category II, contamination Grade 2
Test voltages (type test) mains supply to measurement circuit mains supply to housing between measurement circuits measurement circuits to housing electrical isolation between the analog inputs	with AC supply 2.3kV 50Hz, 1 min; with AC/DC 510V 50Hz, 1 min with AC supply 1.5kV 50Hz, 1 min; with AC/DC 510V 50Hz, 1 min 200V 50Hz, 1 min 500V 50Hz, 1 min up to 30V AC and 50V DC
Supply voltage sensitivity	less than 0.1% of range span
Power consumption	35VA max.
Data buffering	More than 4 years through lithium battery in RAM or 2 days with storage capacitor at 5 — 25°C ambient temperature. Additional backup in EEPROM.
Electrical connection	At rear through plug-in screw terminals, max. conductor cross-section 2.5mm ² or 2x 1.5mm ² with core end sleeves. For Type 954012: Setup connector at the front behind flip-up dot-matrix display
EMC interference emission immunity to interference	EN 61 326 Class B to industrial requirements

Housing (Type 954012 and Type 954013)

Housing type housing door for Type 954012/... housing door for Type 954013/..	Housing for front-panel mounting to DIN 43 700, galvanized sheet steel cast zinc conductive plastic to dissipate electrostatic charges
Transport mechanism	in corrosion-resistant chrome-nickel steel
Chart cassette	in plastic (polycarbonate)
Bezel size	144mm x 144mm
Depth behind panel	212mm without screw terminals; 227mm with screw terminals plugged in
Panel cut-out	138 ^{+1.0} mm x 138 ^{+1.0} mm
Housing mounting	in control panel to DIN 43 834
Ambient temperature range	0 to +50°C
Ambient temperature error	0.2%/10°C
Storage temperature range	-20 to +70°C (without print head), -20 to +55°C (with print head)
Climatic conditions	20 — 70% relative humidity, no condensation
Operating position	normal position: vertical ± 30° (NL 90 ± 30, to DIN 16 257)
Protection	to EN 60 529 Category 2, front IP54, rear IP20
Weight	3.5 kg max.

Operating modes

Type 954012

Limit monitoring

Eight limit comparators are available to monitor the limits.

Limits, differential values (hysteresis), limit comparator functions (lk), texts and the channels to be monitored can be programmed. The result of the monitoring is fed to the open-collector outputs (1 — 3) and the optional relay module (1 — 8) as limit state (logic 0 or 1).

The different lk functions are:

lk 7:

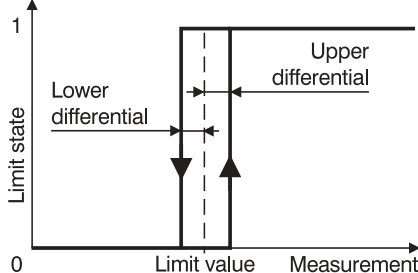

The limit state is set to 1 when: measurement > limit + upper differential.

lk 8:

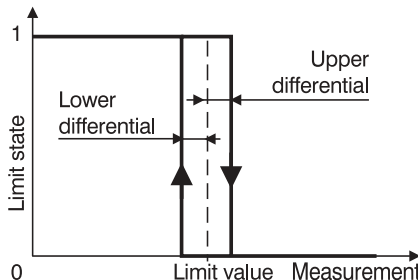

as lk7, but function is reversed.

Chart speeds

The LOGOPRINT 500 can be programmed with four different operating modes for the chart speed:

1. Normal operation
2. Limit operation

If the measurement goes above/below the programmed limits, the recorder switches to the speed which has been programmed under "limit operation".

3. External operation

A signal on one of the logic inputs at the back of the recorder switches to the speed which has been programmed under "external speed".

4. Timed operation

The chart speed which is operative within a programmable time span.

Type 954013

The LOGOPRINT 500 junior has no limit monitoring. Only normal operation is possible as chart speed.

Graphic print-out

Type 954012

Measurement traces

Zoom (plot area)

In zoom operation, an enlarged recording is made of a section of the full range of a trace.

Presentation range (offset)

This parameter is used to define the presentation range of a trace on the chart.

This assists the evaluation, in particular of traces which are close to each other or which overlap.

Peak value recording

The peak value recording can be switched on or off for each channel.

In the switched-off state, the present value of a channel is printed.

Since more values can be measured than can be printed, the minimum and maximum values measured between two lines to be printed are stored when the peak value recording is switched on. These minimum and maximum values are printed when peak value recording is activated.

Event traces

Eight event traces can be printed. Limit monitoring (limit comparators) or the state of the optional logic inputs can thus be documented on the chart.

Type 954013

The entire chart width for each measurement trace is available here. The functions zoom, presentation range, peak value recording and event traces are not applicable.

Text printing

Text printing is used for comments on the recorded trace and for event recording.

Type 954012

Printing priorities can be assigned to texts, to serve as abort criteria during simultaneous text printing requests.

Text printing can be separately configured for each text, either time-optimized or during continued recording of traces.

Type 954013

The priorities and the printing mode are strictly defined here.

Text printing facilities for

Type 954012 and Type 954013:

- Time, date
- Scaling of the channels
- Channel numbers
- Change of chart speed
- Recording start/end text
- "Power on" and "power off" text
- Print text to check the printing system and the service print

Additional text printing facilities for

Type 954012:

- 16 limit comparator texts¹ (eight for underlimit and eight for overlimit)
- 2 reports (calculate and print minimum, maximum and mean values)
- Eight external texts¹ (extra code)
- 16 binary-linked external texts¹ (extra code)
- Event counter¹ (extra code)

1. These texts are buffered through a queue. As long as the queue is not full, complete documentation is assured.

Extra codes

Type 954012

RS422/RS485 interface

This interface is intended for communication with higher-level systems (e. g. bus system or PC). It can be used to read out measurements, to monitor operating states and to transmit texts and values to the recorder.

Logic inputs

Eight logic inputs can be operated either through floating contacts or by the following voltage levels:

inactive: 0 — 5V / active: 20 — 35V

The voltage levels must be applied for 0.4 sec.

Functions available include:

- External start/stop
- Activate external chart speed
- Text printing
- Start/stop external report
- Start scaling print
- Increment two event counters
- Key inhibit
- Event traces

Supply for 2-wire transmitter

An electrically isolated supply for a 2-wire transmitter is available.

24V DC 45 mA ± 5%

ER8 external relay module

The LOGOPRINT 500 can be equipped with an ER8 external relay module (eight relay outputs) to monitor infringements of upper and lower limits. The relay outputs are permanently assigned to the limit comparators. The assignment to the measurement channels can be made freely through the limit comparator parameter.

Contact rating:

3 A 250V AC 50Hz, or 3 A 30V DC resistive load

Display and controls

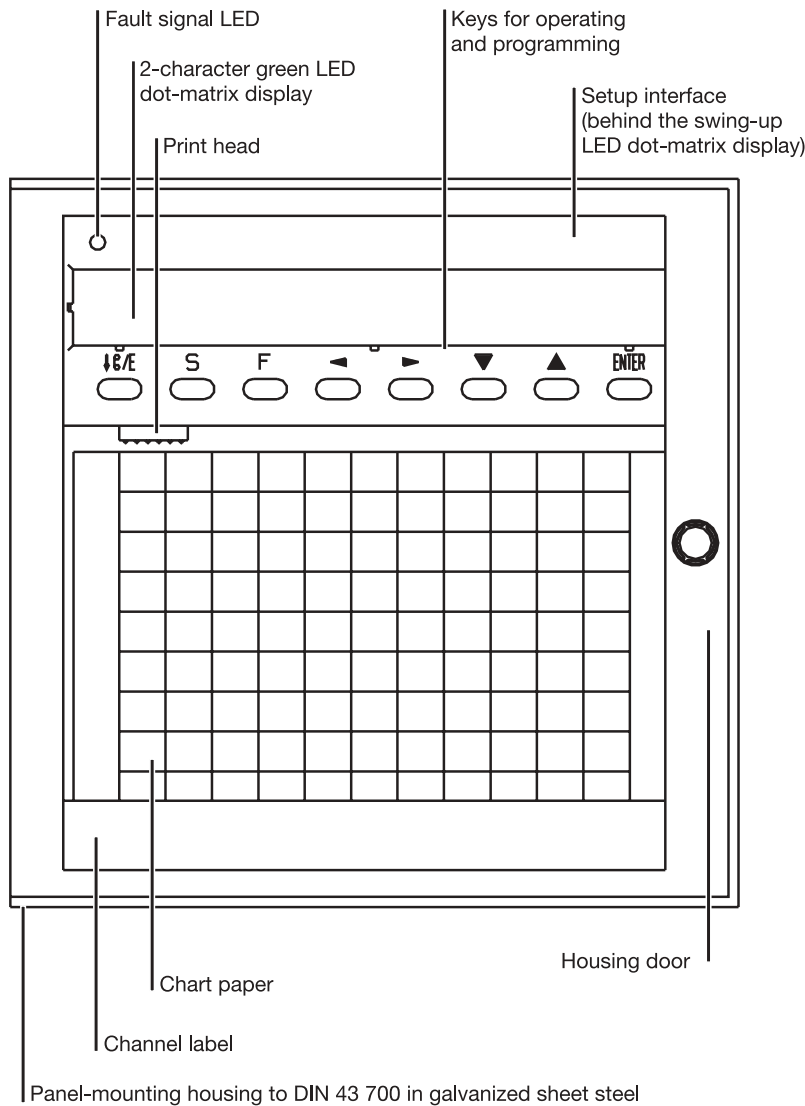

Operation and configuration

Type 954012 and Type 954013

At the recorder

The eight keys on the instrument are used for operating the instrument, and to configure all the parameters essential to the operation.

The 24-character dot-matrix display is available for indicating and monitoring the measurements and parameters.

Type 954012

Via the setup program for PC (accessory)

The recorder can be configured using the setup program for PC (see diagram, bottom left) more conveniently than by using the instrument keys.

The configuration data of a configured instrument can be read out and altered using the setup program.

For a further instrument with the same configuration, the data can be copied through the setup program. The configuration data can be archived on data media and printed out.

In addition to the programming possibilities from the keys of the recorder, the setup program offers the following extra functions:

- Setting different print colors
- Customer-specific linearizations
- Setting the printing mode for the texts (printing mode: "Overwrite measurement trace" or "Interrupt measurement trace")
- Printing priorities
- Math and logic module editor
- Various settings can be managed

Customer-specific linearizations

The setup program offers a choice between linear, square law and cube law linearization. There can be up to 41 calibration points for linear and square law linearization, and up to 61 calibration points for cube law linearization. These calibration points are used to determine the coefficients for polynomials which are defined for each section, so that even a few calibration points produce a smooth graph.

Accuracy: depends on the shape of the graph and the selected linearization.

Language

Type 954012 and Type 954013

The language setting (English, German, French) appears in the print-out and on the LED dot-matrix display.

Setup program (Type 954012)

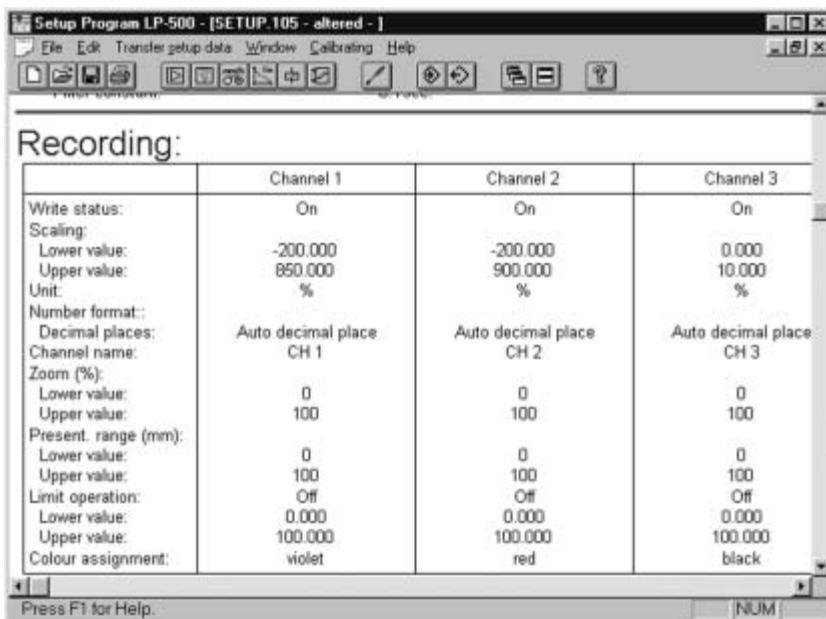

Example of a recording with text print-out for Type 954012

- (1) Recording start/end text
- (2) Speed change to 120 mm/h through a logic input
- (3) Printing the time (with every fourth print-out, the current chart speed, the programmed instrument name, or the date are printed alternately).
- (4) If a selectable logic input is closed, the count of an event counter is incremented and documented together with the programmed text. Altogether, two event counters are available.
- (5) The scaling of all active channels can be printed, either by pressing the **F** key (hold down for at least 4 sec), or through a logic input.
- (6) The channel number can be printed in the selected channel color so that individual traces can be more easily differentiated.
- (7) Documentation of over/underlimit conditions in the limit comparators.
- (8) A total of eight event traces can be printed out. They can be used either to document the state of the limit comparators, or that of the logic inputs. The position of the event traces on the chart can also be programmed.
- (9) Additional texts (external texts) can be printed if one logic input, or a combination of up to four logic inputs, is switched.
- (10) Print-out of a report. The print-out shows the period of time in which the measurements were acquired and calculated, as well as the minimum, maximum and mean values of all active channels (including channel name and unit).
- (11) As opposed to (5), the scaling of the channels can be performed alternately in a programmable spacing.

All texts which relate to a logic input can only be printed if the extra code "8 logic inputs" (code 259) has been implemented in the recorder.

In the example, the traces which were printed above the report (10), are printed out in the normal mode, i.e. all traces share the entire chart width (0 — 100mm). The presentation range can be selected freely on the chart for each trace. This assists the evaluation, in particular of traces which are close to one another or which overlap. The traces below the report have thus been arranged over two sections of the chart (0 — 50mm and 50 — 100mm).

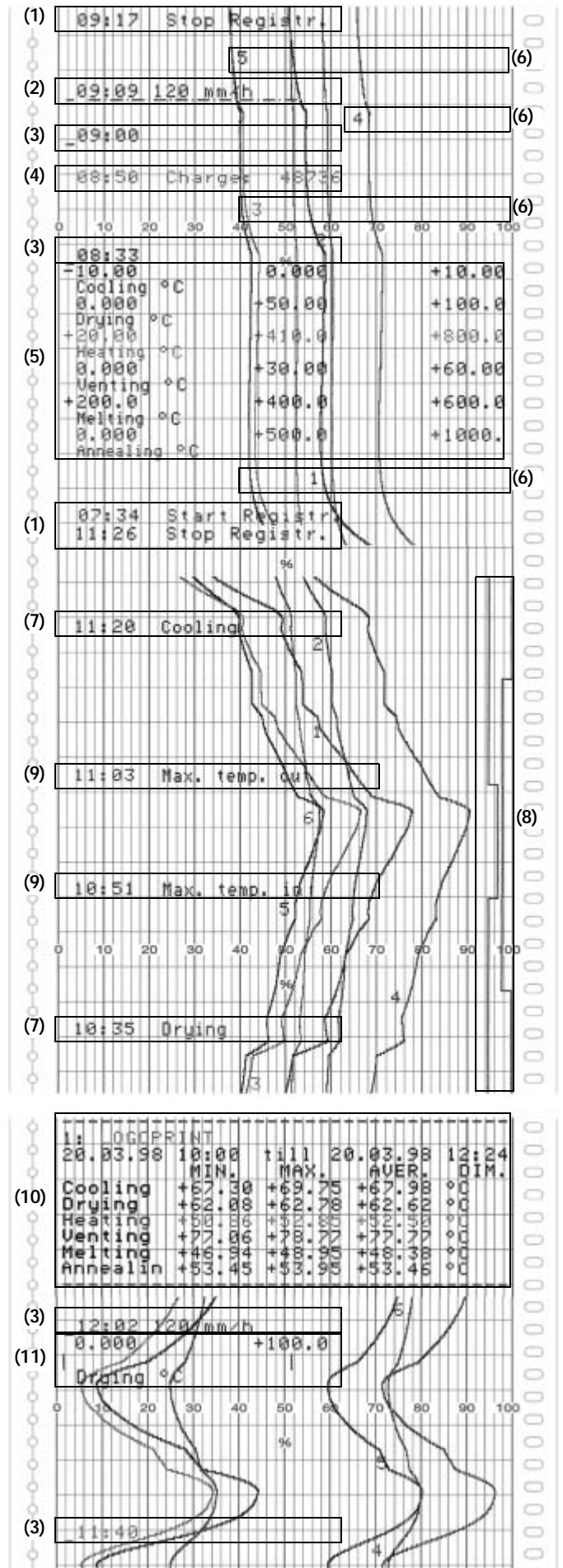

Connection diagram for maximum terminal assignment

Rear view of 3/6-channel version with plug-in screw-clamp connectors

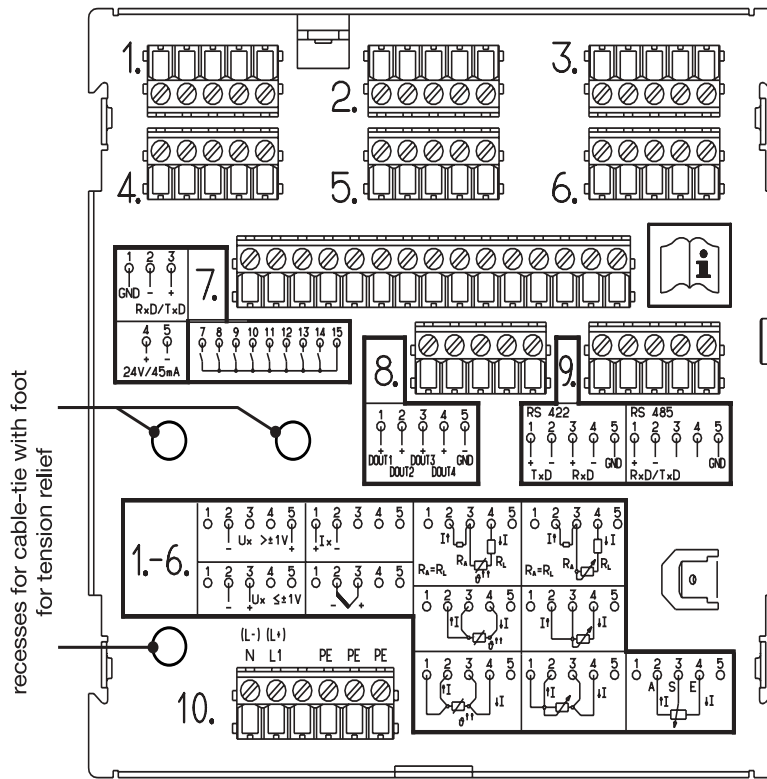

Connection for 3/6-channel version

Diagram

Supply as on label	N neutral L1 line PE protective earth	Connector 10.	(L-) N 1 (L+) L1 2 PE 3 PE 4 PE 5 PE 6
Analog inputs Type 954012 and Type 954013	Inputs		
	1	2	3
	4	5	6
	Connector		
Thermocouple			
Resistance thermometer in 2-wire circuit			
Resistance thermometer in 3-wire circuit	1.	2.	3.
	4.	5.	6.
	Connector		
Resistance thermometer in 4-wire circuit			

Analogue inputs Type 954012	Inputs						Diagram
	1	2	3	4	5	6	
	Connector						
Resistance transmitter in 3-wire circuit							<p>A = start S = slider E = end</p>
Potentiometer in 2-wire circuit							<p>$R_A = R_L$</p>
Potentiometer in 3-wire circuit							
Potentiometer in 4-wire circuit							
Voltage input up to ± 1V	1.	2.	3.	4.	5.	6.	<p>$U_x \leq \pm 1V$</p>
Voltage input above ± 1V							<p>$U_x > \pm 1V$</p>
Current input ± 20mA							<p>I_x</p>
Current input (shunt) ≤ ±20mA (when using transducers with changeable internal resistance; extra code "terminal with shunt" is required)							<p>50Ω I_x</p>

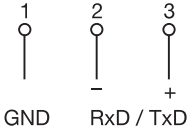
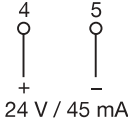
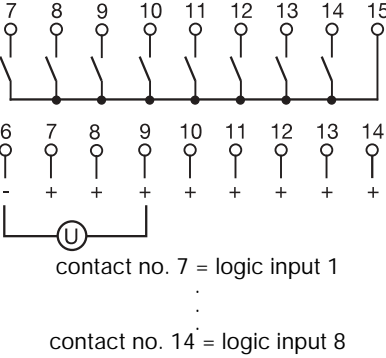
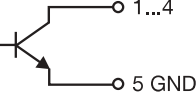
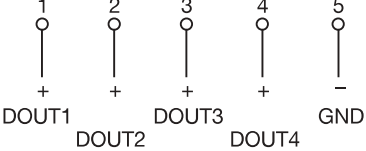
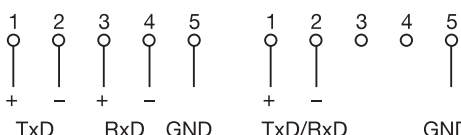
Inputs/outputs Type 954012		Connector	Diagram
ER8 external relay module	Communication with external relay module	7.	
Voltage source for external 2-wire transmitter	24V 45mA ± 5%		
Logic operating inputs min. pulse length: HIGH 400msec LOW 400msec	Contact operation LOW = $R_{OFF} \geq 100k\Omega$ HIGH = $R_{ON} \leq 50k\Omega$ Voltage operation LOW = 0 — 5V DC (inactive) HIGH = 20 — 35V DC (active)		
Open-collector outputs 	DOUT1 — DOUT4 $U_{max} = 32V DC$ $I_{max} = 100mA$ Residual voltage DOUT active $U_{DOUTactive} = 0.4 — 1.2V$	8.	
RS422/RS485 serial interface	Communication with higher-level systems	9.	RS 422 RS 485 

Overview of the electrical isolation

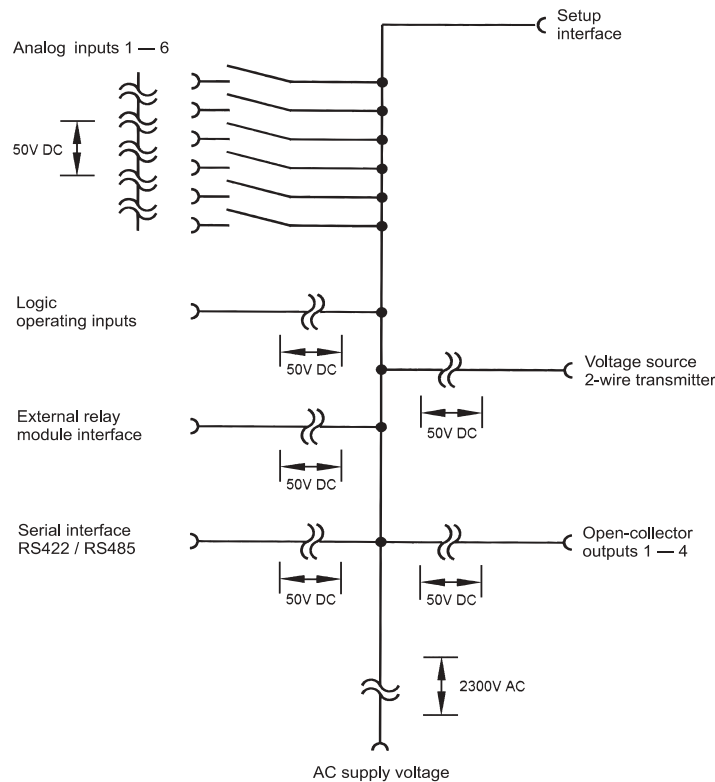

Dimensions

Panel-mounting housing

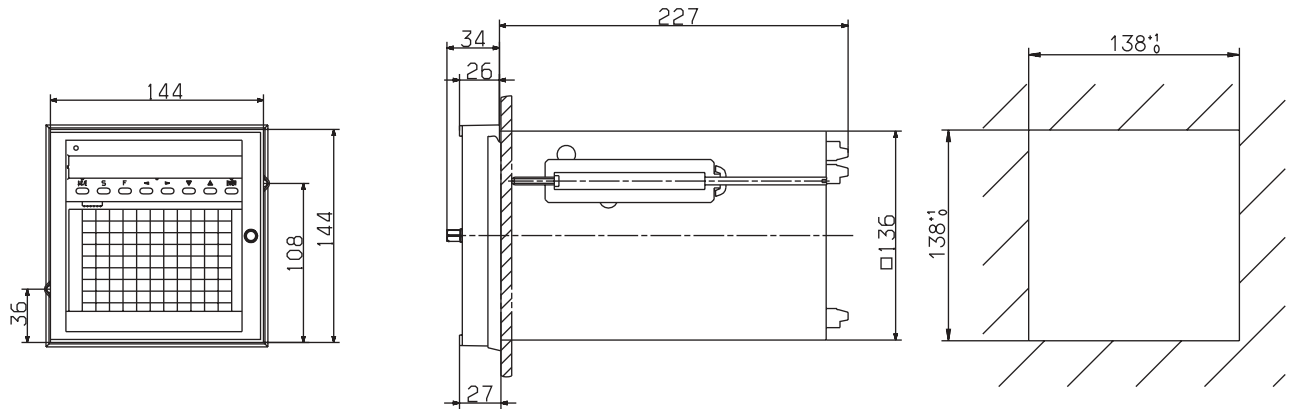

Extra code

Housing with carrying handle, rubber feet and terminal cover, also 3m mains cable with earthed plug

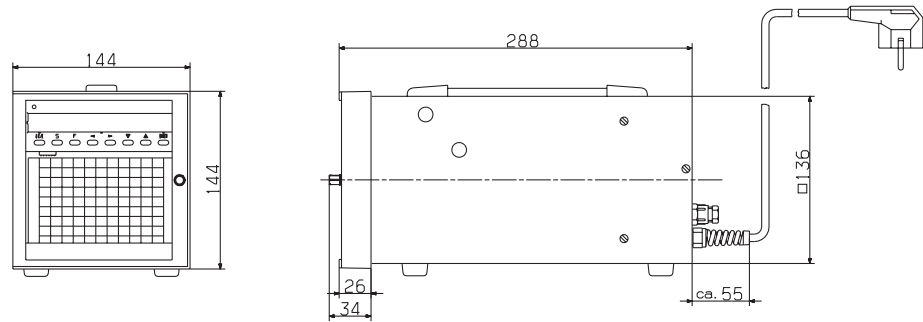

Extra code

Housing for wall mounting. The panel-mounting housing is fitted in a carrier and can be swung out through 90°.

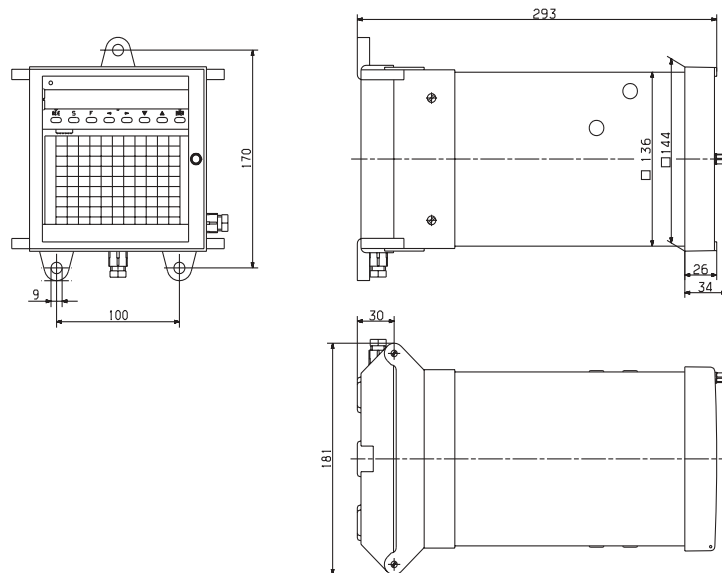

Extra code "TG-35"

Portable recorder housing for varying applications in mobile use

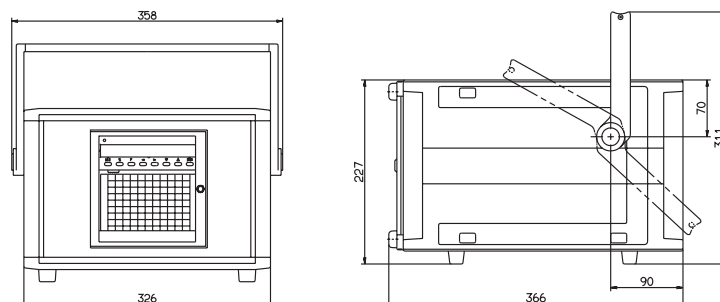

Ordering details

Basic type (1) (2) (3) (4) (5) (6)
954012 / - , - - / , ...¹

Basic type (1) (2) (3) (4) (5) (6)
954013 / 15 - , - 00 - / , ...¹

(1) Basic type extensions

Connectors	Code
I: 3 analog inputs ²	14
I/II: 3/3 analog inputs	15

(2) Inputs (programmable) with 3 channels

Inputs on connector I	Code
factory-set	888
configuration to customer specification	999

(3) Inputs (programmable) with 6 channels

Inputs on connector II	Code
not assigned ²	000
factory-set	888
configuration to customer specification	999

(4) RS422/RS485 interface

At rear	Code
not assigned	00
RS422, Jbus, MODbus ²	52
RS485, Jbus, MODbus ²	53

(5) Supply

At rear	Code
110 — 240V AC +10/-15% 48 — 63Hz	23
20 — 53V AC/DC +0/-0% 48 — 63Hz	22

(6) Extra codes

	Code
lithium battery for RAM buffer (ex-factory)	020
storage capacitor for RAM buffer (on request)	021
8 logic inputs ² , interface ² for external relay module (ER8), voltage output ² 24V 50mA DC	259
terminal with shunt (6 items)	030
door with lock (IP54)	265
IP65 seal, wide fixing brackets	266
universal portable housing TG-35	350
housing with carrying handle	351
housing for wall mounting (can be swung through 90°)	247

Accessories for programming²

setup program on two 3.5" diskettes, multi-lingual
PC interface cable with TTL/RS232 converter

Accessory²

ER8 external relay module (extra code 259 is required)
--

1. extra codes are listed in sequence and separated by a comma
2. only for Type 954012

Standard accessories

- 1 Operating Instructions
- 2 mounting brackets
- cable-tie with foot (can be released), for tension relief of the sensor leads connected
- 1 print head, 3 colors (each color is available twice) or
1 print head, 6 colors
- 1 roll chart 32m long, and
1 fanfold chart pack 16m long

Consumables

Print head (2 items)

- 3 colors
Part No. 00355244
- 6 colors
Part No. 00355255

Roll chart (5 rolls)

- no name, % graduation, linear overall length: 16m overall width: 120mm Part No. 00331497
- no name, % graduation, linear overall length: 32m overall width: 120mm Part No. 00331499
- no name, special graduation, linear (marked as specified)

Fanfold chart (5 packs)

- no name % graduation, linear overall length: 16m overall width: 120mm Part No. 00331490
- no name, special graduation, linear (marked as specified)

Ordering examples

954012/15-888,888-00-23/020,259

- 954012 Logoprint 500
- 15 6 analog channels
- 888,888 all channels factory-set
- 00 no RS422 or RS485 interface
- 23 AC supply
- 020 lithium battery (ex-factory)
- 259 8 logic inputs, interface for ER8, voltage output 24V 50mA DC for 2-wire transmitter

954013/15-888,888-00-23/021

- 954013 Logoprint 500 junior
- 15 6 analog channels
- 888,888 factory-set
- 00 no interface
- 23 AC supply
- 021 storage capacitor