

DATA SHEET

Form 246-011130

Part Number	Description
G4PB16	G4 16-Channel I/O Module Rack

Description

The G4PB16 I/O mounting rack accommodates up to 16 G4 I/O modules. Insert and remove modules easily and quickly without disturbing field wiring. Modules are secured to the mounting rack with a threaded captive hold-down screw.

Barrier strips with screw terminals provide the field and mounting rack power connections. A header connector accepts a standard 50-pin cable for the logic connections.

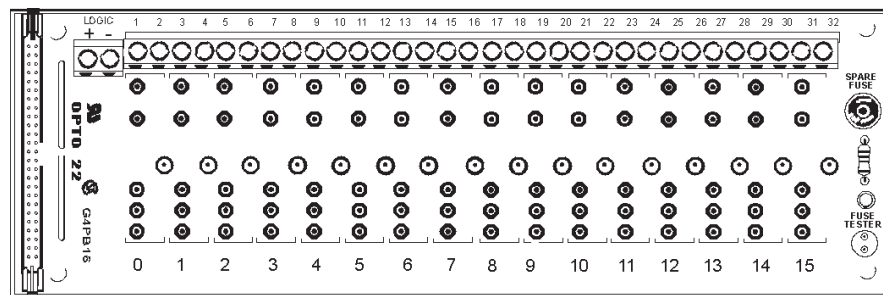

Features

- Requires minimum panel space
- Built-in fuse tester
- Spare fuse on board
- UL recognized, CSA certified, CE approved
- Uses a single 5, 15, or 24 VDC power supply for control power

Specifications

Operating temperature:	0 to 70° C 95 percent relative humidity, non-condensing
Interface connector: Field: Control:	Screw-type barrier strip accommodates up to 10 AWG wire 50-conductor header connector

Dimensions

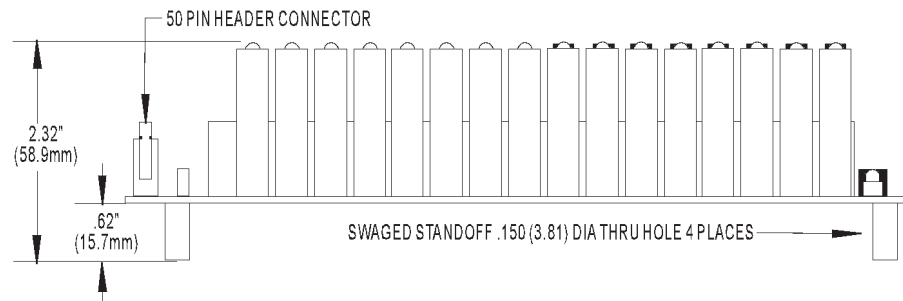
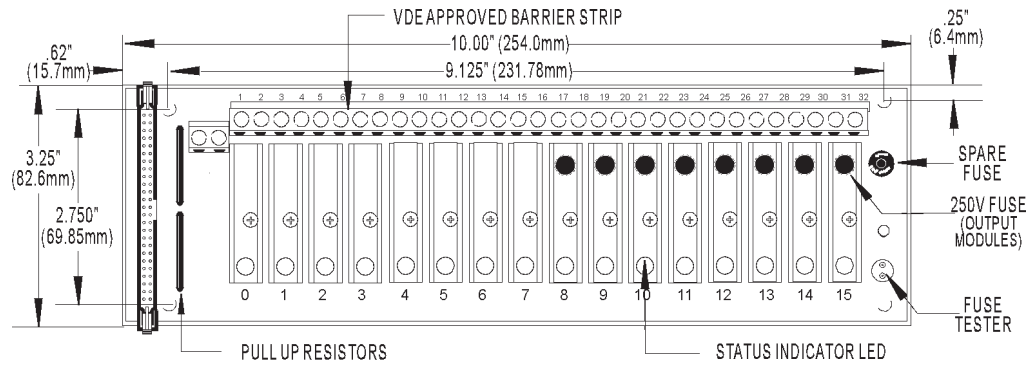

Connections

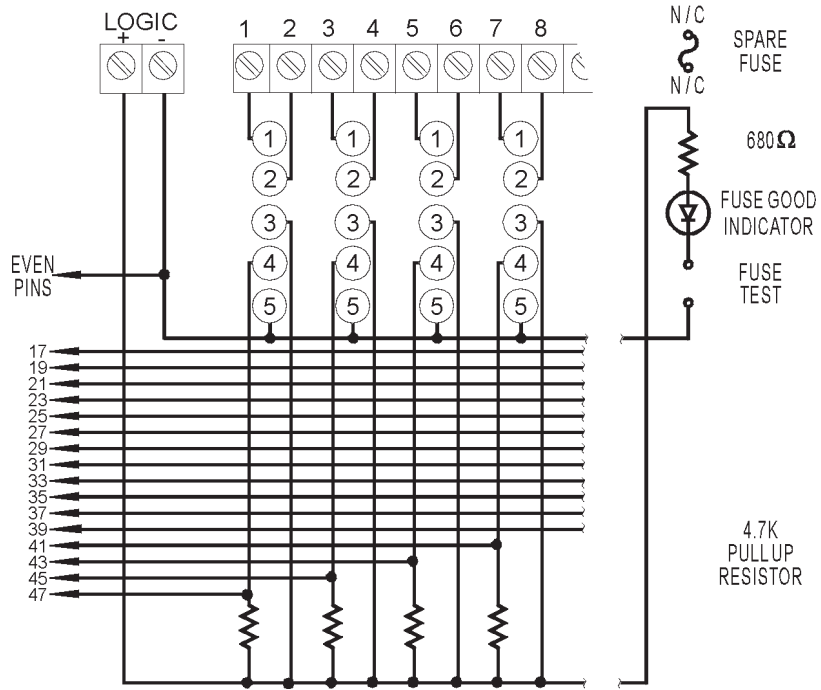

DATA SHEET

Form 246-011130

Connections (CONT.)

Notes:

1. Even pins on control connector are connected by etch to common.
2. +VCC and return connected to terminals marked LOGIC + and -.
3. At each module position on the field terminal strip, the lower number is always connected to pin 1 of the I/O module.

Module Position	Control (Header Connector)	Field (Terminal Strip)
0	47	1 and 2
1	45	3 and 4
2	43	5 and 6
3	41	7 and 8
4	39	9 and 10
5	37	11 and 12
6	35	13 and 14
7	33	15 and 16
8	31	17 and 18
9	29	19 and 20
10	27	21 and 22
11	25	23 and 24
12	23	25 and 26
13	21	27 and 28
14	19	29 and 30
15	17	31 and 32

LATEST PRODUCTS PRODUCT SUPPORT COMPANY INFORMATION

More About
OPTO 22

Products

Opto 22 produces a broad array of reliable, flexible hardware and software for industrial automation and remote monitoring. Opto 22's diverse and complete product range allows you to buy in at any level, from solid-state relays to fully integrated control systems.

SNAP Ultimate I/O™

The most intelligent and powerful I/O system available, SNAP Ultimate I/O effectively combines I/O, control, networking, and enterprise connectivity into a single cohesive system. SNAP Ultimate I/O has the ability to communicate *directly* with enterprise systems, eliminating the need for complex middleware and the significant investments associated with it. Software and utilities for use with SNAP Ultimate I/O include ioControl™ flowchart-based control programming software and ioDisplay™, a Windows-based HMI development package.



SNAP Ethernet I/O™

Using SNAP Ethernet I/O systems, you can connect a wide variety of electronic and mechanical devices such as lights, temperature and pressure sensors, motors, and serial devices to computers via a standard Ethernet network, wireless LAN, or even the Internet.



SNAP-IT™ Systems

A packaged solution that brings industry-proven SNAP Ethernet technology to your enterprise faster and easier than ever before, SNAP-IT is a Web-enabled hardware appliance that connects environmental, device, and other sensors directly to your enterprise applications. The connected devices can then be controlled and real-time operational data can be collected, monitored, and delivered via a standard Ethernet, wireless LAN, or dial-up network.



Opto 22 FactoryFloor™ Software

FactoryFloor is an integrated suite of industrial control software applications designed to help you develop control automation solutions, build easy-to-use operator interfaces, and expand your manufacturing systems' connectivity.



Other Software and Hardware

Software developer kits (SDKs), diagnostic utilities, support for the Linux operating system, and a full line of SNAP industrial controllers are also available from Opto 22.



Quality

In delivering hardware and software solutions for worldwide device management and control, Opto 22 retains the highest commitment to quality.

We do no statistical testing; each product is made in the U.S.A. and is tested twice before leaving our 160,000 square-foot manufacturing facility in Temecula, California. That's why we can guarantee solid-state relays and all optically-isolated I/O modules *for life*.

Product Support

Opto 22's Product Support Group offers comprehensive technical support for Opto 22 products. The staff of support engineers represents years of training and experience, and can assist with a variety of project implementation questions. Product support is available in English and Spanish from Monday through Friday, 8 a.m. to 5 p.m. Pacific Standard Time.

Opto 22 Web Sites

www.opto22.com
www.ManageTheRealWorld.com
www.internetio.com (live Internet I/O demo)
www.ultimateio.com (SNAP Ultimate I/O information)

Other Resources

- OptoInfo CDs
- Ongoing, up-to-date training
- Integration support
- FaxBack service: (800) 474-OPTO

About Opto 22

Founded in 1974, Opto 22 is a leading manufacturer of high-quality hardware and software solutions for connecting real-world devices with computer networks. Customer applications include enterprise management, remote monitoring and control, industrial automation, and data acquisition. Opto 22 was one of the first companies to recognize and implement solutions involving networks, computers, and real-world equipment and devices. More than 65 million devices worldwide are reliably connected to Opto 22 systems.

